

# AZ9371

## SENSITIVE SUBMINIATURE RELAY

### FEATURES

- Extremely small footprint
- Thin vertical profile only 0.275" (7 mm) wide
- High sensitivity, 113 mW pickup
- Dielectric strength 4000 Vrms
- 5 Amp switching capability (version "T" 10 Amp)
- Two different footprints available
- UL, CUR file E44211
- VDE Pending

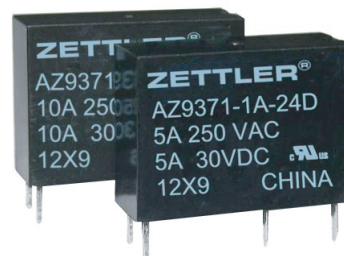

### CONTACTS

<b>Arrangement</b>	SPST (1 Form A)
<b>Ratings</b>	Resistive load: Max. switched power: 150 W or 1385 VA (Version "T": 300 W or 2770 VA) Max. switched current: 5 A (Version "T": 10 A) Max. switched voltage: 30 VDC* or 277 VAC * Note: If switching voltage is greater than 30 VDC, special precautions must be taken. Please contact the factory.
<b>Rated Load UL/CSA</b>	5 A at 277/250/125 VAC General Use [1][2] 5 A at 30 VDC General Use [1][2] B300 Pilot Duty 120/240 VAC, 125/250VAC [2] "T" Version 10 A at 277/250/125 VAC General Use [1][2] 10 A at 30 VDC General Use [1][2]
<b>VDE Pending</b>	5 A at 250 VAC / 30 VDC [1][2]
<b>Material</b>	Silver nickel [1], silver tin oxide [2], gold plating available
<b>Resistance</b>	< 100 milliohms initially (at 6 V, 1 A, voltage drop method)

### COIL

<b>Power</b>	
<b>At Pickup Voltage (typical)</b>	113 mW
<b>Max. Continuous Dissipation</b>	750 mW at 20°C (68°F) ambient
<b>Temperature Rise</b>	26°C (47°F) at nominal coil voltage
<b>Temperature</b>	Max. 105°C (221°F)

### NOTES

1. All values at 20°C (68°F).
2. Relay may pull in with less than "Must Operate" value.
3. Specifications subject to change without notice.

### GENERAL DATA

<b>Life Expectancy</b>	Minimum operations 5 million operations
<b>Mechanical</b>	
Standard version	
<b>Electrical</b>	1 X 10 <sup>5</sup> at 5 A, 250 VAC res. [1] 5 X 10 <sup>4</sup> at 5 A, 250 VAC res. [2]
High capacity version "T"	
<b>Electrical</b>	1 X 10 <sup>5</sup> at 7 A, 250 VAC res. [1] 1 X 10 <sup>4</sup> at 10 A, 250 VAC res. [1][2] 3 X 10 <sup>4</sup> at 7 A, 250 VAC res. [2]
<b>Operate Time (typical)</b>	10 ms at nominal coil voltage
<b>Release Time (typical)</b>	10 ms at nominal coil voltage (with no coil suppression)
<b>Dielectric Strength (at sea level for 1 min.)</b>	4000 Vrms coil to contact 1000 Vrms between open contacts
<b>Insulation Resistance</b>	1000 megohms min. at 20°C, 500 VDC, 50% RH
<b>Dropout</b>	Greater than 5% of nominal coil voltage
<b>Ambient Temperature</b>	At nominal coil voltage
<b>Operating Storage</b>	-40°C (-40°F) to 85°C (185°F) -40°C (-40°F) to 105°C (221°F)
<b>Vibration</b>	0.062" (1.5 mm) DA at 10–55 Hz
<b>Shock</b>	10 g
<b>Enclosure</b>	P.B.T. polyester
<b>Terminals</b>	Tinned copper alloy, P.C.
<b>Max. Solder Temp.</b>	270°C (518°F)
<b>Max. Solder Time</b>	5 seconds
<b>Max. Solvent Temp.</b>	80°C (176°F)
<b>Max. Immersion Time</b>	30 seconds
<b>Weight</b>	3 grams



**AMERICAN ZETTLER, INC.**

[www.azettler.com](http://www.azettler.com)

75 COLUMBIA • ALISO VIEJO, CA 92656 • PHONE: (949) 831-5000 • FAX: (949) 831-8642 • E-MAIL: SALES@AZETTLER.COM

# AZ9371

---

## RELAY ORDERING DATA

COIL SPECIFICATIONS				
Nominal Coil VDC	Must Operate VDC	Max. Continuous VDC	Coil Resistance Ohm $\pm$ 10%	ORDER NUMBER
3	2.25	3.9	45	AZ9371-1A-3D
5	3.75	6.5	125	AZ9371-1A-5D
6	4.50	7.8	180	AZ9371-1A-6D
9	6.75	11.7	405	AZ9371-1A-9D
12	9.00	15.6	720	AZ9371-1A-12D
18	13.50	23.4	1620	AZ9371-1A-18D
24	18.00	31.2	2880	AZ9371-1A-24D

\*Add "T" after "AZ9371" for high capacity version. Add "E" after "1A" to indicate silver tin oxide contacts. Add suffix "E" for sealed version. Add suffix "K" for K version footprint. Add suffix "G" at the end of order number for gold plated contacts.



**AMERICAN ZETTLER, INC.**

[www.azettler.com](http://www.azettler.com)

75 COLUMBIA • ALISO VIEJO, CA 92656 • PHONE: (949) 831-5000 • FAX: (949) 831-8642 • E-MAIL: SALES@AZETTLER.COM

# AZ9371

## MECHANICAL DATA

### Standard Pinning Outline Dimensions

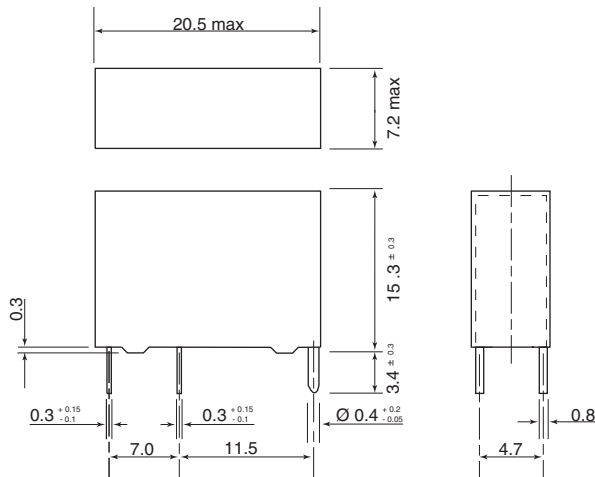

### Version "K" Pinning Outline Dimensions

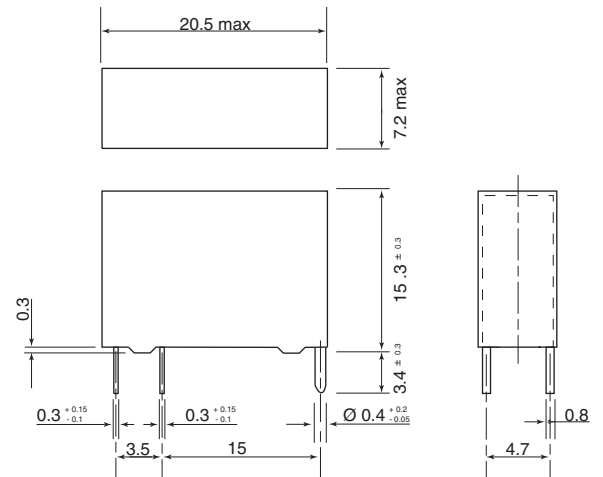

### PC BOARD LAYOUT

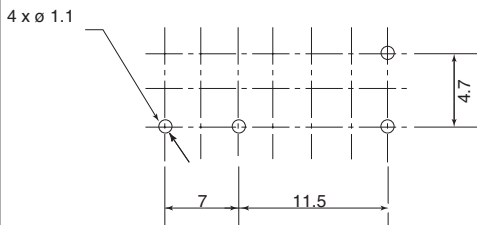

Viewed toward terminals

### WIRING DIAGRAM

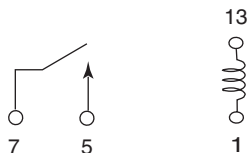

Viewed toward terminals

### PC BOARD LAYOUT

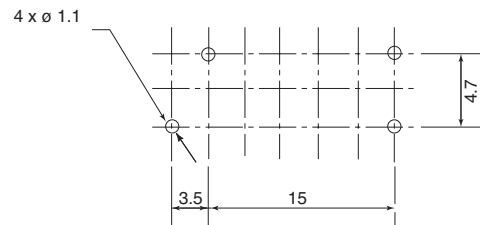

Viewed toward terminals

### WIRING DIAGRAM

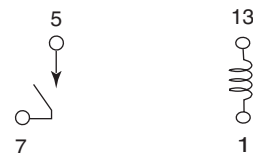

Viewed toward terminals

Attention! Grid is not 0.1" (2.54 mm)!!



**AMERICAN ZETTLER, INC.**

[www.azettler.com](http://www.azettler.com)

75 COLUMBIA • ALISO VIEJO, CA 92656 • PHONE: (949) 831-5000 • FAX: (949) 831-8642 • E-MAIL: SALES@AZETTLER.COM