

SPECIFICATIONS

VOLTAGE RATING: 50V DC
CURRENT RATING: 25mA
INITIAL RESISTANCE: 50 m Ω after 1 x 10⁵ cycles at maximum.
LIFE AT MAXIMUM SWITCHING LOAD: 1,000,000 cycles
TRAVEL: .7mm (.028")
OPERATING FORCE: 120 gf
OPERATING TEMPERATURE RANGE: HRF -25° to + 75°C
CIRCUIT: SPDT, SPST
SNAP TIME: Closing < 50µs, Opening < 200µs
FUNCTIONS AVAILABLE: Momentary, Non-Shorting (BBM)

MATERIALS

HOUSING: PC-CF
KNOB: ABS or equivalent
MOVING CONTACT: CrNi Au
FIXED CONTACT: Silver plated copper alloy

The 320 Series switches are being used in a variety of applications for a great number of industries. Available features include:

- Tactile feel push buttons . . . for a distinctive difference
- Choice of contact design . . . for SPST, SPDT
- Flexibility of layout . . . for single key or keyboard construction
- .1" installation grid . . . for standardization of layout

HOW TO ORDER

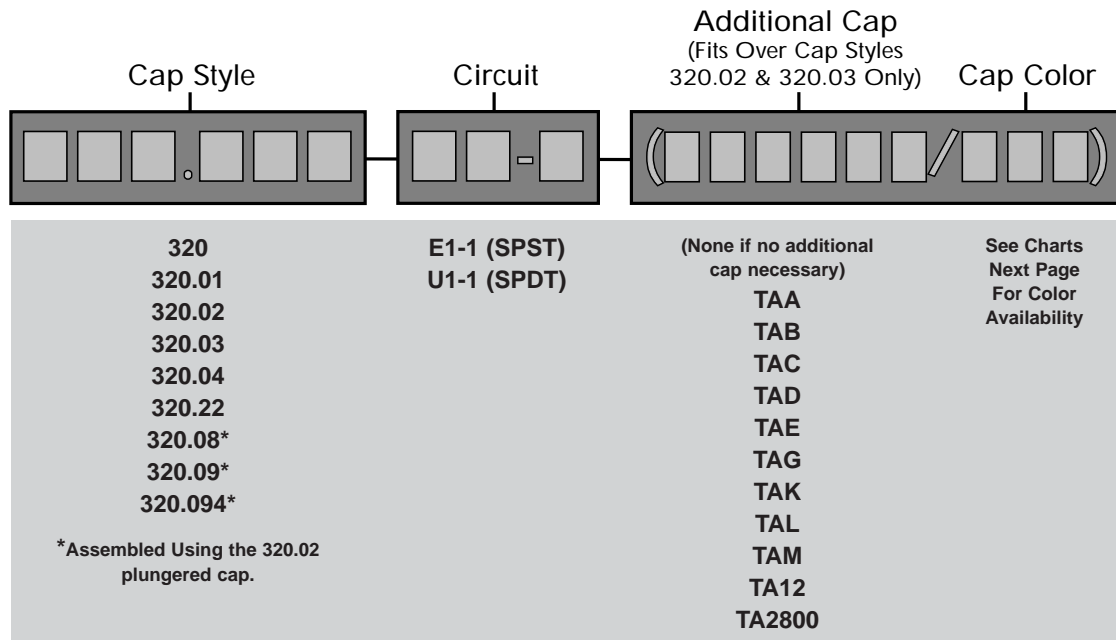

SPECIFICATIONS SUBJECT TO CHANGE WITHOUT NOTICE.

Example:

320.03 → U1-1 → TAL/GRY
 320.08 → E1-1 → YEL