

792/792H

FEATURES

- Automotive, 30-40 amps
- Q.C./Plug-in/Solder-lug
- Flanged Cover Options
- Sockets available



ORDERING INFORMATION

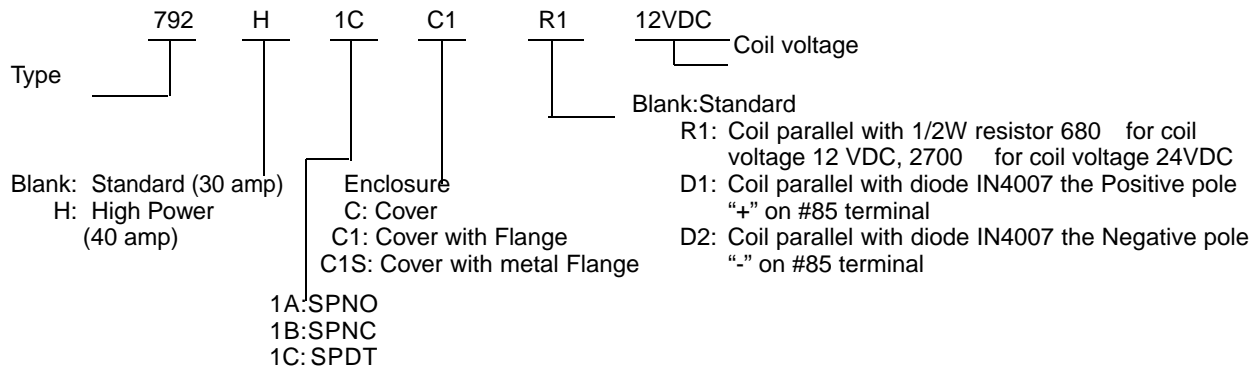

CONTACT RATING

Resistive Load	Standard Type	High Power Type
	1A: 30A 12VDC	1A: 40A 12VDC
	1B: 20A 12 VDC	1B: 30A 12 VDC
	1C: NO 30A 12VDC	1C: NO 40A 12VDC
	NC 20A 12VDC	NC 30A 12VDC

COIL DATA

	12VDC	24VDC
Nominal voltage	12VDC	24VDC
Pull in voltage (Max) at 20°C	7.8VDC	17VDC
Drop out voltage (Min) at 20°C	1.2VDC	2.4VDC
Coil resistance at 20°C	80 ±10%	320 ±10%

SPECIFICATION

Operating temperature	Standard type	-40 ~ +85° C
	High power type	-40 ~ +70° C
Voltage drop between contact terminal (initial value)	300mV (AT 10AMPS)	
Operate time	10 ms Max.	
Release time	10 ms Max.	
Insulation resistance	50 M Min. (DC 500V)	
Dielectric strength	AC 500V, 50/60Hz 1 min.	
Vibration resistance	10~55Hz, amplitude 2.0 mm	
Life Expectancy	Mechanical	>10,000,000 operations (frequency 18,000 operations/hr)
	Electrical	>100,000 operations (frequency 1,200 operations/hr)
Weight	Approx. 40g	