

Connector for miniSD™ Card

SCJB2B02 Series

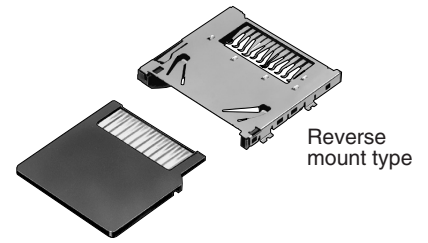

Reverse mount type

Compact, low-profile size is optimum for portable devices.
 (Outside dimensions: 24.7×21.7×2.2 mm/Card ejection 4.5 mm)

Applications

Mobile phones, Personal Digital Assistants, digital cameras, digital camcorders, etc.

Products List

Model	Media ejection structure	Mounting system	Top-surface shape	Packing style
SCJB1B0102	Push-push type	Standard mount	Flat	Taping
SCJB2B0102			With cover	
SCJB2B0101		Reverse mount	With cover	Tray
New SCJB2B0201			Flat	Taping

Typical Specifications

Items	Specifications	
Structure	Applicable media	miniSD™ Card
	Mounting system	Surface mounting type
	Mounting system	Standard mount/Reverse mount
	Media ejection structure	Push-push type
Performance	Operating temperature range	-25°C to +70°C
	Voltage proof	500V AC 1minute
	Insulation resistance (Initial)	1,000MΩ min.
	Contact resistance (Initial)	Connector contacts, 100 mΩ max. Detection switch, 500 mΩ max.
	Mating and unmating cycles	10,000 cycles

Dimensions

Reverse mount type
SCJB2B0201

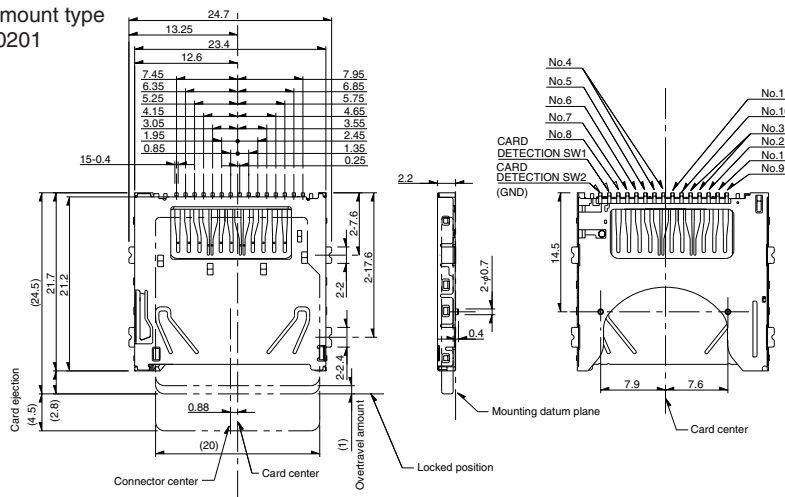

PC board mounting hole dimensions

Unit:mm

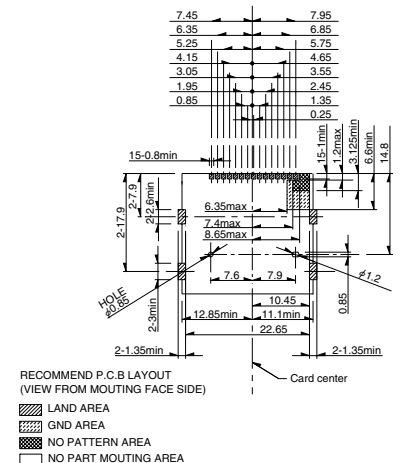

Operating Precautions

- Unless specifically indicated otherwise, this product has been designed and manufactured for use in ordinary electronic equipment and devices, such as AV equipment, electric home appliances, office machines, and communications equipment. Equipment manufacturers are consequently advised that when these products are planned for equipment that requires a high degree of safety and reliability, especially those apparatuses like medical equipment, aviation and aircraft equipment, space equipment, and burglar alarm equipment, the manufacturers should assure equipment safety by providing protection circuits and redundant circuitry and should fully study the suitability of such products for the intended equipment.
- Specification indicated in this catalog is outline only. When employing the product, use of an officially authorized specification for supply contract is recommended.
- The external appearance, performances, and other properties of the product may be changed for improvement without prior notice.
- miniSD card is a trademark of SD Association.
- Names for products and companies and titles of specifications indicated in this catalogue are mostly trademarks or registered trademarks of their respective owners.
- Please contact us for any enquiries and queries on our products and their uses.
- This catalog is valid till the end of December 2005.

Inquiries about Products

Products Information Center +81 (3) 5499-8154
 Products Catalog Site <http://www3.alps.co.jp>

ALPS ELECTRIC CO., LTD.

1-7, Yukigaya-otsuka-cho, Ota-ku, Tokyo, 145-8501