

New



FEATURES

- 1. Compact Size**
W 40 × L 58 × H 25.5 mm
W 1.575 × L 2.283 × H 1.004 inch
- 2. With terminal cover for safety (output side only).**
* Cover on input side available as option.
- 3. Mounting pitch 47.5 mm 1.870 inch**
- 4. Built in varistor for excellent surge absorption**
- 5. With LED indication for operation status verification**

TYPICAL APPLICATIONS

- Heater control
- **Business use:**
Cooking machine, Vending machine, Freezer and Refrigerator
 - **Industrial use:**
Molding machine, Temperature controlled bath, Printing machine and Packing machine

Compliance with RoHS Directive

ORDERING INFORMATION

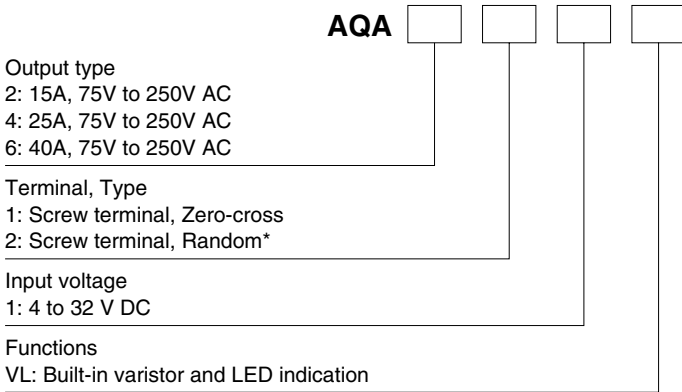

* Random type is available by custom order.

TYPES

1. AQ-A Solid State Relays

Type	Load current	Load voltage	Input voltage	Part No.
Zero-cross	15A	75V to 250V AC	4 to 32V DC	AQA211VL
	25A			AQA411VL
	40A			AQA611VL

Standard Packing; carton: 2 pcs., case: 60 pcs.
Note: Random type also available. Please inquire.

2. Accessories

Type	Part No.	Packaged quantity
Standard heat sink (15A)	AQP-HS-J10A	5 in a carton, 20 in a case
Standard heat sink (25A)	AQP-HS-30/40A	5 in a carton, 20 in a case
Standard heat sink (40A)	AQP-HS-J25A	No carton, 5 in a case
Slim heat sink (45mm wide) (Mountable on a DIN rail)	AQP-HS-SJ20A	No carton, 8 in a case
DIN rail mounting plate	AQP-DPJ	5 in a bag, 50 in a case
Terminal cover	AQA801	—

RATING

1. Ratings (Measurement condition: at 20°C 68°F, Input ripple: 1% or less)

Item	Part No.	AQA211VL	AQA411VL	AQA611VL	Remarks
Input side	Input voltage	4 to 32V DC			
	Input current	Max. 20mA			
	Drop-out voltage	Min. 1V			
Output side	Max. load current	15A	25A	40A	
	Load voltage	75 to 250V AC			
	Frequency	45 to 65Hz			
	Non-repetitive surge current	150A	250A	400A	
	"OFF-state" leakage current	Max. 10mA			
	"ON-state" voltage drop	Min. 1.6V			
	Min. load current*	100mA			

Note: * When the load current is less than the rated minimum load current, please refer to "Cautions for Use".

2. Characteristics (Measurement condition: at 20°C 68°F, Input ripple: 1% or less)

Item	AQA211VL	AQA411VL	AQA611VL	Remarks
Operate time	Max. 1/2 cycle of voltage sine wave + 1ms			
Release time	Max. 1/2 cycle of voltage sine wave + 1ms			
Insulation resistance	Min. 100MΩ between input and output			at 500 V DC
Breakdown voltage	4,000 Vrms between input and output 2,500 Vrms between input, output and case			for 1min.
Vibration resistance (Functional)	10 to 55Hz double amplitude of 1.5mm			X, Y, Z axes
Shock resistance (Functional)	Min. 980 m/s ²			X, Y, Z axes
Ambient temperature	-20°C to +80°C -4°F to +176°F			Non-condensing at low temperatures
Storage temperature	-20°C to +85°C -4°F to +185°F			Non-condensing at low temperatures
Operational method	Zero-cross (Turn ON and Turn OFF)			

REFERENCE DATA

1. Load current vs. ambient temperature

Use load current within range specified in the figure below.

Tested condition

With external heat sink

- 1) (1) When using standard heat sink (AQP-HS-J25A)
- (2) When using standard heat sink (AQP-HS-30/40A)
- (3) When using standard heat sink (AQP-HS-J10A)
- (4) When using standard heat sink (AQP-HS-SJ20A)
- 2) If attached to a heat sink, use a heat conductive compound (Ex. Momentive Performance Materials Inc. YG6111 or TSK5303) of similar coating to improve cooling.

Without external heat sink

If the mounting surface is not metallic and a heat sink is not used, expose the bottom surface and plate surface to improve heat dissipation.

(1) 15A type (AQA211VL)

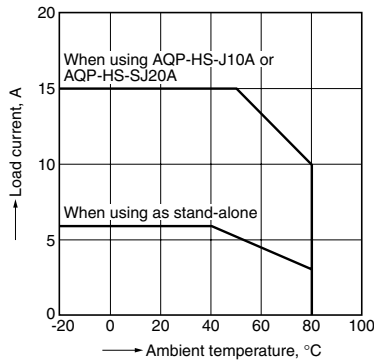

(2) 25A type (AQA411VL)

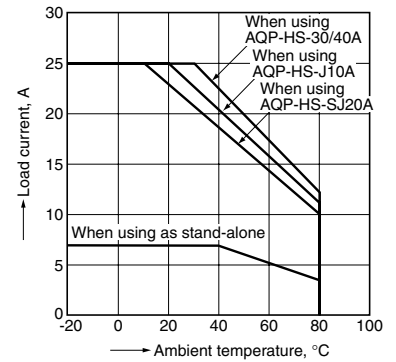

(3) 40A type (AQA611VL)

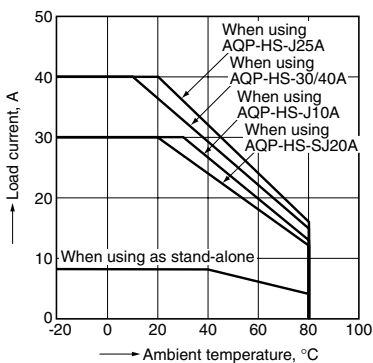

2. Non-repetitive surge current vs. carrying time characteristics

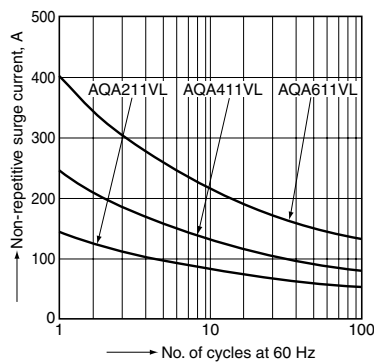

3. Input current vs. input voltage characteristics

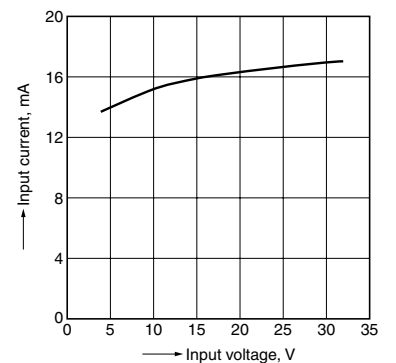

AQ-A

DIMENSIONS (mm inch)

The CAD data of the products with a **CAD Data** mark can be downloaded from: <http://panasonic-electric-works.net/ac>

CAD Data



External dimensions

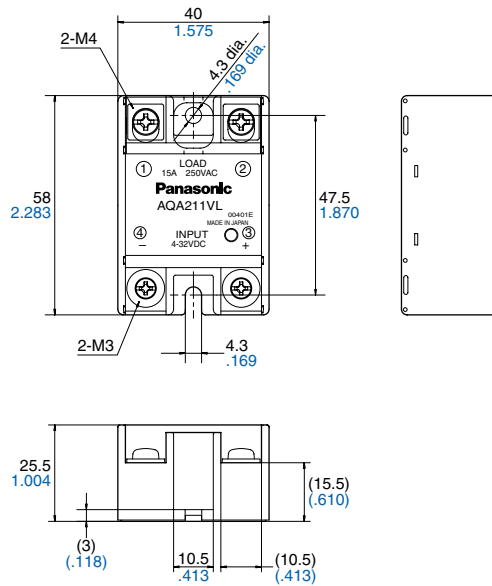

Schematic

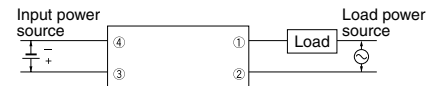

Mounting dimensions

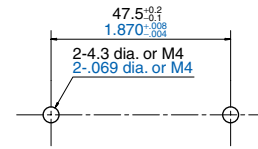

ACCESSORIES (mm inch)

AQP-HS-SJ20A Slim Heat Sink

CAD Data



External dimensions

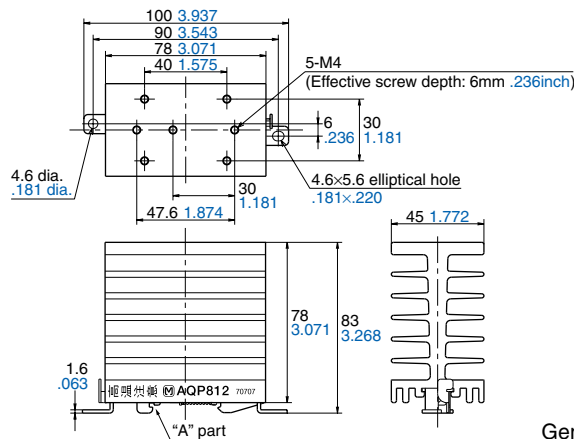

Mounting dimensions

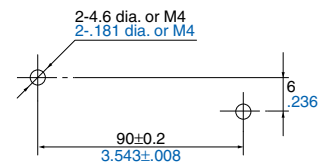

Note: When using on a DIN rail, please install so that the "A" part is on top.

General tolerance: ±1.0 ±.039

AQP-HS-J10A Standard Heat Sink

CAD Data



External dimensions

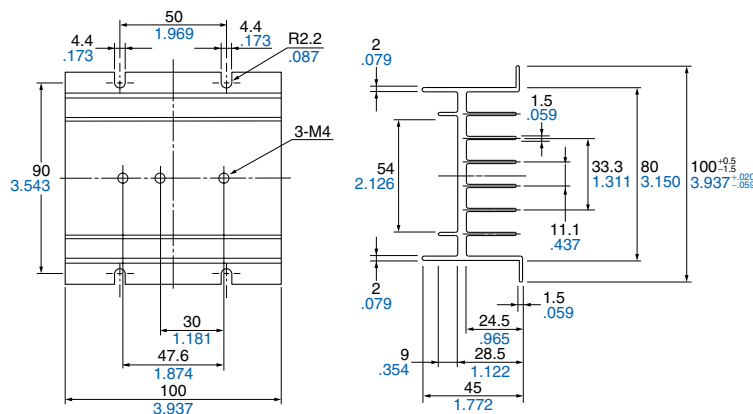

Mounting dimensions

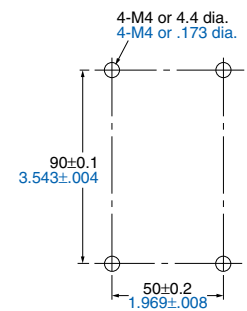

AQP-HS-30/40A Standard Heat Sink

External dimensions

Mounting dimensions

CAD Data

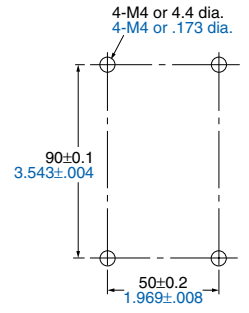
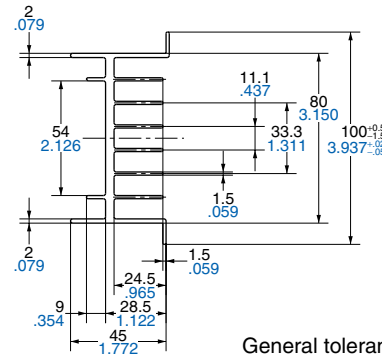
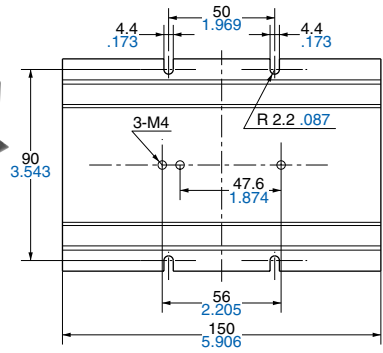

General tolerance: $\pm 0.5 \pm .020$

AQP-HS-J25A Standard Heat Sink

External dimensions

Mounting dimensions

CAD Data

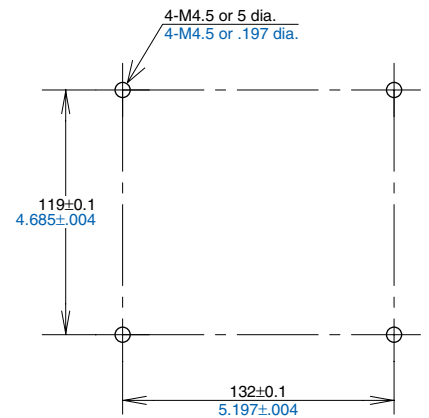
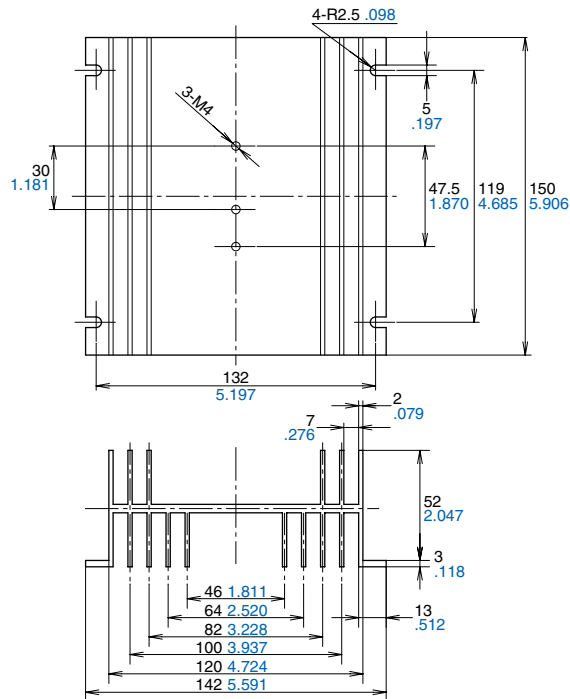
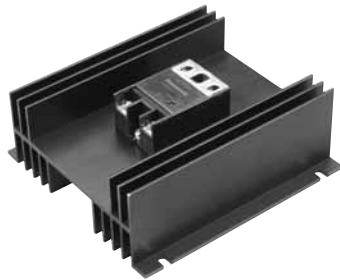

AQP-DPJ DIN Rail Mounting Plate

AT8-DLA1 Mounting Rail

CAD Data

CAD Data

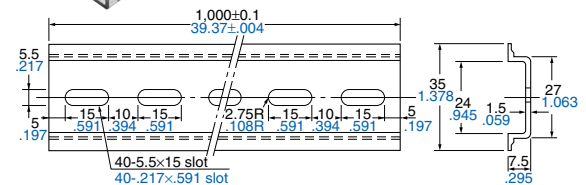
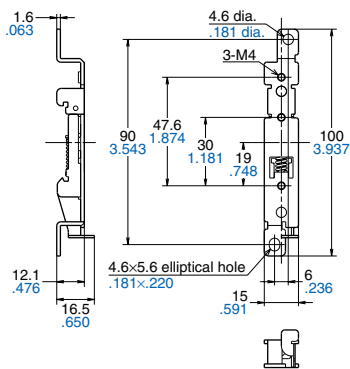

ATA4806 Fastening plate

CAD Data

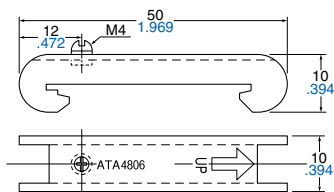

AQ-A

NOTES

1. Part number indication

The AQ-J slim heat sink combined type is a product combining the AQ-J SSR and AQ-J SSR heat sinks. The part numbers are indicated on each AQ-J SSR and heat sink.

Ex) In the case of AQJ112VY

Part number of AQ-J SSR: AQJ112V

Part number of the heat sink: AQP810*

When using these parts, please refer to REFERENCE DATA, "1. Load current vs. ambient temperature".

Note: * The Japanese part number is printed on the following accessories in stead of Global part number. Please refer to the below chart for interpretation from Japanese to Global part number.

Products	Japanese Part No.	Global Part No.	Compatible models
Slim heat sink (28 mm)	AQP810	AQP-HS-SJ10A	AQ-J
Slim heat sink (45 mm)	AQP812	AQP-HS-SJ20A	AQ-A, AQ-J
Standard heat sink (10A and 15A)	AQP811	AQP-HS-J10A	AQ-A, AQ-J
Standard heat sink (25A and 40A)	AQP808	AQP-HS-J25A	AQ-A, AQ-J
Standard heat sink (AQ-A 25A)	AQP804	AQP-HS-30/40A	AQ-A
DIN Rail Mounting Plate (for AQ-A and AQ-J)	AQP809	AQP-DPJ	AQ-A, AQ-J
Mounting Rail	ATA48011	AT8-DLA1	AQ-A, AQ-J
Terminal Cover (for AQ-A)	AQA801	AQA801	AQ-A

Cautions for Use

1. Noise and surge protection at the input side

A high noise surge voltage applied to the SSR input circuit can cause malfunction or permanent damage to the device. If such a high surge is anticipated, use C or R noise absorber in the input circuit.

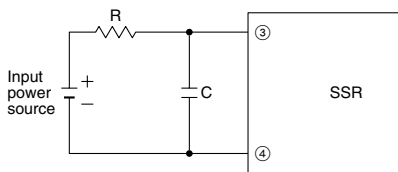

2. When the input terminals are connected with reverse polarity

Reversing the polarity will not cause damage to the device, due to the presence of a protection diode, but the device will not operate.

3. In the case of operating voltage containing ripple

If the SSR control voltage contains ripple, the peak of the ripple should not exceed the maximum rated control voltage (32V), and the bottom of the ripple should exceed the minimum rated control voltage (4V).

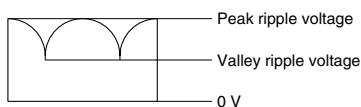

4. When used for the load less than rated at the output side

An SSR may malfunction if it is used below the specified load. In such an event, use a dummy resistor in parallel with the load.

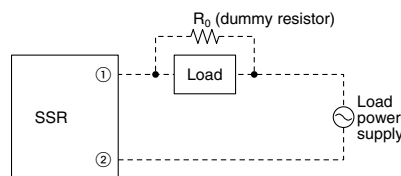

Set a value of dummy resistor so that the load current becomes 100 mA or more (AQ-A) or 50 mA or more (AQ-J) due to the dummy resistor and load.

5. Others

- 1) If an SSR is used in close proximity to another SSR or heat-generating device, its ambient temperature may exceed the allowable level. Carefully plan SSR layout and ventilation.
- 2) Terminal connections should be made by referring to the associated wiring diagram.
- 3) When mounting a heat sink, coat it with a heat conducting compound or similar in order to improve the heat dissipation effect.
- 4) The product is hot during and immediately after operation. Use caution.

5) When mounting a slim heat sink (AQP-HS-SJ10A, AQP-HS-SJ20A) on a DIN rail, mount it as per the instructions in Note of the dimensional drawing. Mounting in the opposite direction may cause disengagement due to vibration or impact.

6) For higher reliability, check device quality under actual operating conditions.

6. Transportation and storage

- 1) Extreme vibration during transport will warp the terminal or damage the relay. Handle the carton and case with care.
- 2) Storage under extreme conditions will cause external appearance defects, and deterioration of the characteristics. The following storage conditions are recommended:
 - Temperature: 0 to 45°C 32 to 113°F
 - Humidity: Less than 70% R.H.
 - Atmosphere: No harmful gasses such as sulfurous acid gas, minimal dust.