

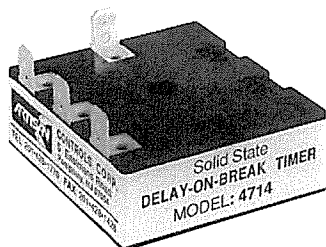

Solid State Timers and Controllers



4714

Zero-Power Delay-On-Break Time Delay Relay

The model 4714 is an all solid state timer that provides delay-on-break timing control over a SPST set of internal relay contacts. Called Zero Power because the model 4714 requires no current from the main power prior to the closure of the initiate switch. Intended for service in applications such as fork lift trucks, and other battery powered automotive type equipment. The model 4714 offers excellent transient protection and provides for reliable timing control. The model 4714 is capable of controlling remote DC loads to 3 amperes at voltages up to 36V DC. Closure of the Initiate Switch turns on the remote load circuit and resets the

timing to zero. Opening the initiate switch starts a preset timing period. The load circuit remains energized until the timing period has elapsed, then de-energizes, returning to the Zero Power state. If the initiate switch is reclosed before the timing period has been completed, the timing cycle will reset and the load circuit will remain energized.

Mechanical & Wiring

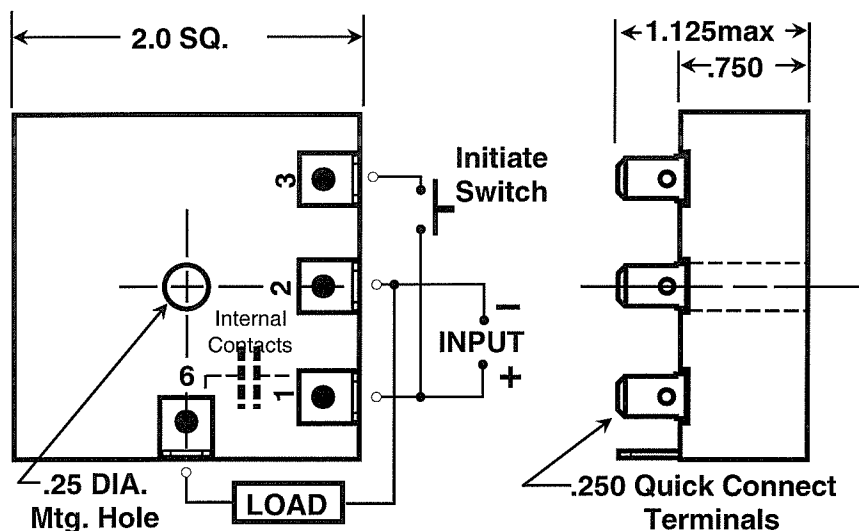

Timing Diagram

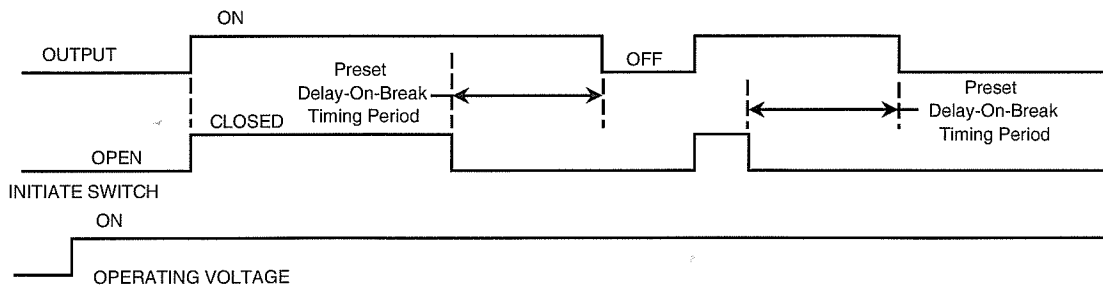

Artisan Controls Corporation,
111 Canfield Ave, Bldg B15-18, Randolph, New Jersey 07869, USA
Tel: 973-598-9400 • Fax: 973-598-9410 • Toll Free: 800-457-4950
website: www.artisancontrols.com



Solid State Timers and Controllers

Specifications

- Voltage:** 24 Volts to 36 Volts DC - Reverse polarity protected.
- Standby Current:** Zero.
- Operating Current:** 40 mA maximum at 36 volts DC plus output load current.
- Timing Mode:** Delay-On-Break.
- Timing Control:** Initiate Switch must be closed for a minimum of 100 milliseconds for the 4714 to assure a recycle condition permitting full timing cycle to repeat.
- Initiate Switch Characteristics:** Isolated SPST rated for 10 mA service - Load current does not flow through initiate switch. Initiate switch may be located up to 10 feet from timer wiring terminals.
- Recycle Time:** Initiate switch may be re-closed 25 milliseconds after the output contacts have opened.
- Fixed Timing:** 0.1 seconds to 10,000 seconds.
- Tolerances On Fixed Timing:** ±10%.
- Repeatability Of Timing Period:** ±1% nominal.
- Output:** SPST set of relay contacts switching the + side of the DC operating voltage to the external load circuit.
- Output Contact Rating:** 3.75A 24V, 2.5A 36V DC resistive.
- Contact Dielectric:** 750Vrms breakdown voltage between open contacts, 1000Vrms breakdown voltage between all contacts and operating voltage terminals.
- Insulation Resistance:** 1000MΩ at 500V DC.
- Mechanical Life Expectancy:** 10⁸ operations.
- Electrical Life Expectancy:** 2 x 10⁵ operations at 2.5A 36V DC resistive, 5 x 10⁴ operations with inductive loads with L/R = 7 milliseconds.
- Transient Protection:** Output Switch protected by silicon transient suppressors responding to transients within 1 x 10⁻¹² seconds to a peak pulse power dissipation of 1500 watts, with transient surge currents to 200 amperes for durations up to 1/120 second at 25° C. Maximum transient voltage protection is 6000 volts as delivered through a source resistance of 30 ohms with a maximum duration of 8.3ms.
- Dielectric:** 1500V rms all terminals to case.
- Operating Temperature:** -40°C to +65°C
- Construction:** Encapsulated module with .25 quick connect wiring terminals.
- Data Sheet Revision Date:** October 31, 1995

Ordering Information All Models

Part Number	Delay On Break Time	Operating Voltage
4714 -	Specify Delay-On-Break Time in Seconds From 0.1 To 10,000	24V To 36V DC

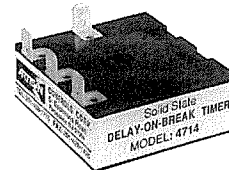

Examples Of Part Numbers

- 4714 - 0.1 Model 4714 operating as a Delay-On-Break with fixed timing of 0.1 seconds.
- 4714 - 250 Model 4714 operating as a Delay-On-Break with fixed timing of 250 seconds.
- 4714 - 600 Model 4714 operating as a Delay-On-Break with fixed timing of 600 seconds.
- 4714 - 8500 Model 4714 operating as a Delay-On-Break with fixed timing of 8500 seconds.