

# USB Connectors XM7

## Small Interface Connectors that Conform to USB Standards

### Mini-USB Connectors

- Insertion life of 5,000 insertions
- Right-angle DIP terminals or right-angle SMT terminals
- RoHS Compliant

### USB Connectors

- USB A-type sockets for mounting on personal computers and USB hubs. USB B-type sockets for mounting on printers, scanners, mice and other peripheral computer devices.
- RoHS compliant



**NEW**

## Ordering Information

### USB Connectors - A-types and B-types

Appearance	A-type, straight DIP kinked terminals	A-Type, right-angle DIP kinked terminals	Stacked A-Type, right-angle DIP kinked terminals	B-type, right-angle DIP kinked terminals
Model	XM7A-0441	XM7A-0442	XM7A-0442-A	XM7B-0442

### USB Connectors - mini-USB types

Appearance	Right-angle DIP terminals	Right-angle SMT terminals
Model	XM7D-0512 <b>NEW</b>	XM7D-0514 <b>NEW</b>

## Model Number Legend

### A-Type and B-Type

XM7  $\square$  - 04 4  $\square$  -  $\square$   
 1 2 3 4 5

**1. Type**

- A: A-type socket
- B: B-type socket

**2. Number of contacts**

- 04: 4 contacts

**3. Plating Specification**

- 4: Gold plated

**4. Terminal Shape**

- 1: Straight (A-type sockets only)
- 2: Right angle

**5. Special Code**

**A-Type Sockets**

- Blank: 1 socket (black housing)
- A: 2 stacked sockets (black housing)

**B-Type Sockets**

- Blank: White housing

### Mini-USB

XM7D - 05 1  $\square$   
 1 2 3 4

**1. Type**

- D: mini-B-type socket

**2. Number of Contacts**

- 05: 5 contacts

**3. Plating Specification**

- 1: Gold Plated

**4. Terminal Shape**

- 2: Right-angle DIP terminals
- 4: Right-angle SMT terminals

## ■ Ratings and Characteristics

Type	A-type and B-type	Mini-USB
Rated current	1 A	
Rated voltage	30 VAC	
Contact resistance	30 mΩ max. (at 20 mV, 100 mA max., excluding cable conductor resistance)	50 mΩ max.
Insulation resistance	1,000 MΩ min. (at 500 VDC)	100 MΩ min.
Dielectric strength	750 VAC for 1 min. (Leakage current: 0.5 mA max.)	100 VAC for 1 min. (Leakage current: 0.5 mA max.)
Total insertion force	35.3 N max.	35 N max.
Total removal force	10 N max.	7 N max.
Insertion durability	1,500 insertions	5,000 insertions
Ambient operating temperature	- 40 to 60°C (with no icing)	0 to 50°C (with no icing)

Note: Refer to the product specification for details

## ■ Materials and Finish

Type	A-type	B-type	Mini-USB
Housing	Fiber-glass reinforced PBT resin (UL94V-0)/black	Fiber-glass reinforced PBT resin (UL94V-0)/white	LCP resin
Contacts	Mating end: Phosphor bronze/nickel base, gold plating Terminals: Phosphor bronze/nickel base, tin alloy plated		Copper Alloy
Shell	Copper alloy/tin plated		Copper alloy

## Dimensions

(Unit: mm)

### Mini-USB

#### XM7D-0512

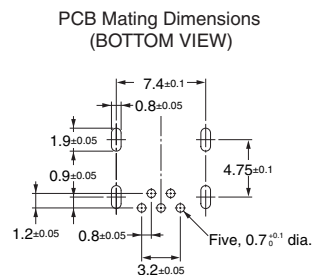
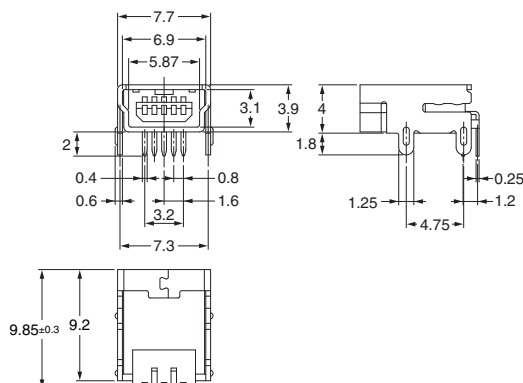

#### XM7D-0514

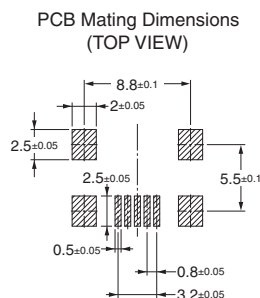
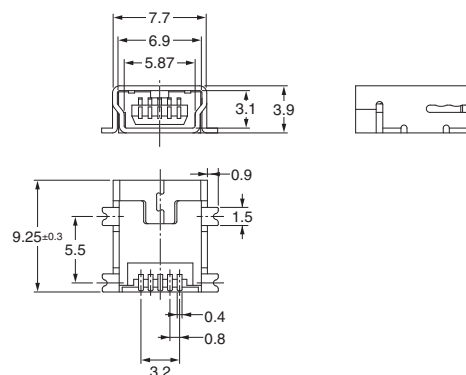

**A-type**

**XM7A-0441  
Straight DIP kinked terminals**

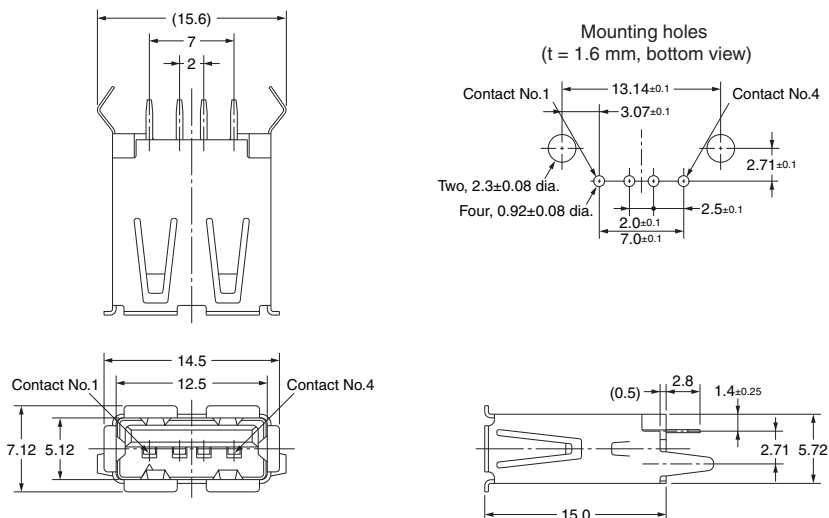
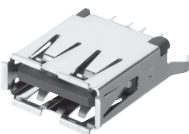

**XM7A-0442  
Right-angled DIP kinked terminals**

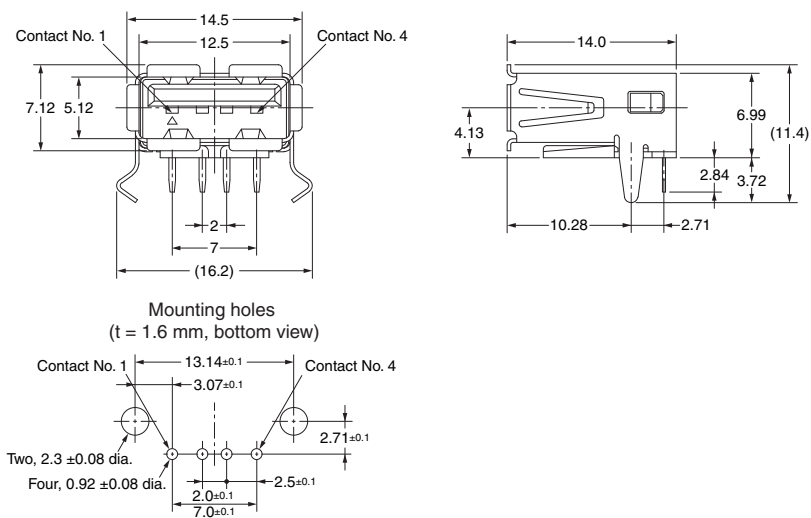
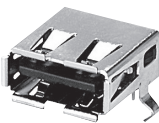

**XM7A-0442-A  
Stacked, 2 connectors  
Right-angled DIP kinked terminals**

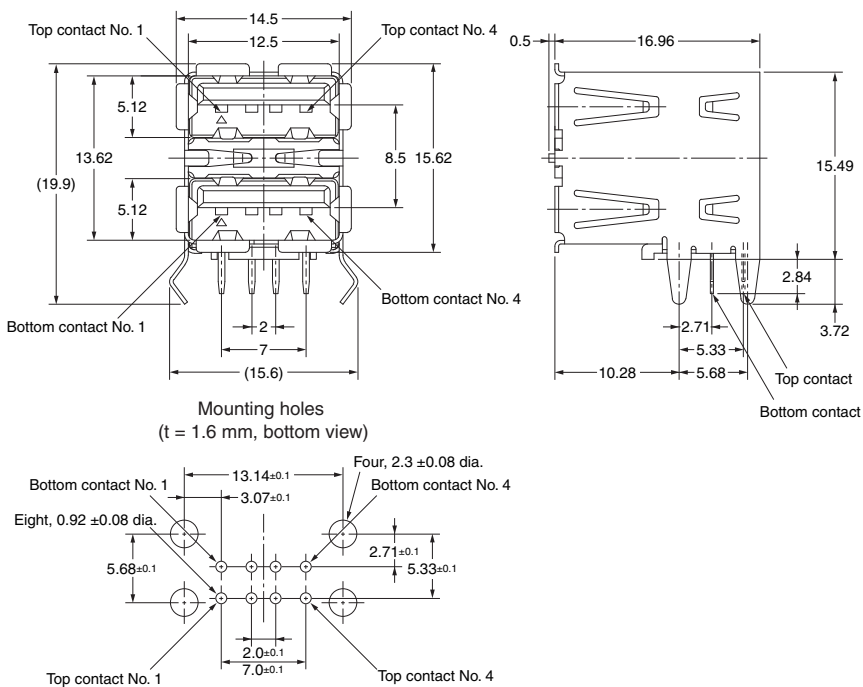
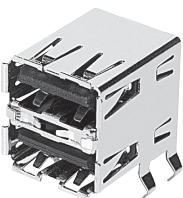

**B-Type**

**XM7A-0442**  
**Right-angled DIP**  
**kinked terminals**

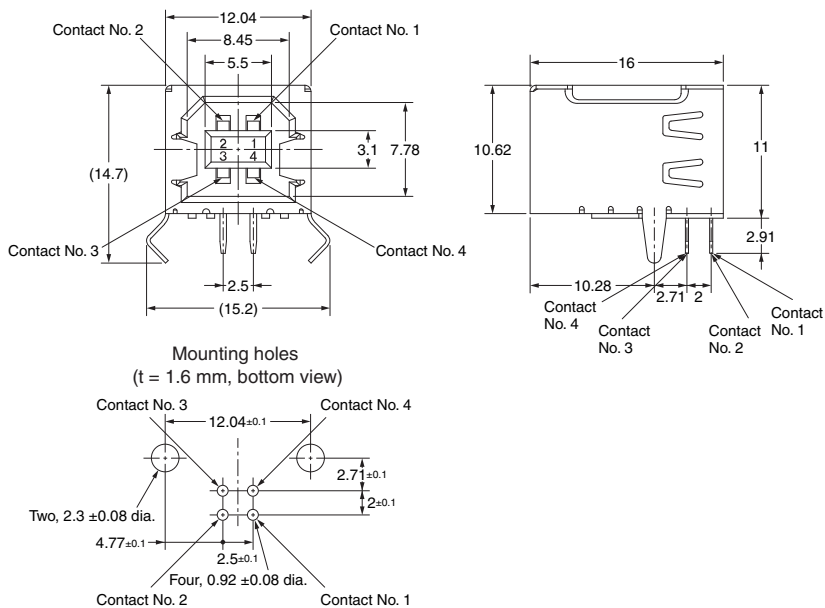

**Accessories (sold separately)**

**Dust Covers**

**XM7Z-0001**

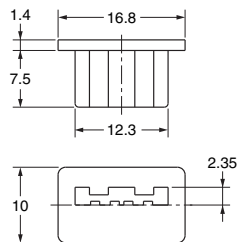
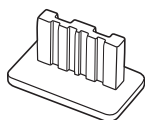

Model	Applicable Connectors
<b>XM7Z-0001</b>	XM7A-0441 XM7A-0442 (One A-Type Socket)
<b>XM7Z-0002</b>	XM7B-0442 (One B-Type Socket)

**XM7Z-0002**

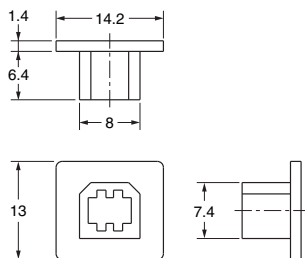
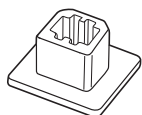

**Characteristics / Material**

<b>Ambient operating temperature</b>	- 40 to 60°C
<b>Material</b>	Polyethylene resin

# Precautions

## ■ Correct Use

### General Environmental Conditions

Do not use the product in any atmosphere or environment that exceeds the ratings.

### Automatic Soldering

Reference: Automated Soldering Conditions (Jet Flow);

- Soldering temperature:  $250 \pm 5^{\circ}\text{C}$
- Continuous soldering time:  $5 \pm 1$  seconds max.

### Soldering Conditions

Reference: Reflow Conditions;

- Maximum temperature:  $260^{\circ}\text{C}$
- Time: 5 to 15 seconds max.

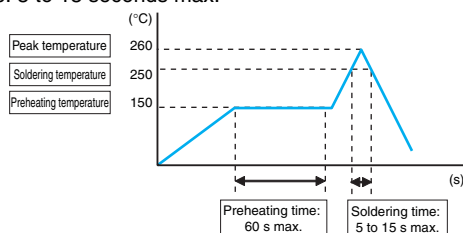

These conditions, however, depend on the type of solder, the manufacturer, the amount of solder, the size of the board, and other mounting materials.

### Screen Thickness for Printing Cream Solder

We recommend a metal mask thickness of 0.15 mm when printing cream solder.

The appropriate conditions however, depend on the type of solder, the manufacturer, the amount of solder the size of the circuit board, other mounting materials and other conditions

### Terminal Shapes

The terminals will deform if they are subjected to an excessive load, which will in turn reduce solderability when mounting. Do not drop the connectors or handle them carelessly. Do not connect anything when the connectors are not mounted to a board. Doing so may deform the terminals.

### Using an Automatic Solder Bath after Reflow

Mask the mating portions with tape before you perform automatic soldering to prevent flux or solder from entering the mating portion of the Connector. Select and use a suitable masking tape.

### Application Precautions

Confirm that there is no excessive misalignment or inclination in the mating contact portion between the plug and socket before mating the connector. Make sure that the connector is mated all the way to the back. If the connector is not mated all the way to the back, contact reliability may be lost.

Do not apply an extreme load during connector insertion or removal. The connector may be damaged, and contact failure may result. Twist the plug and socket as little as possible when mating the connector. Not doing so may deform the terminals or housing or crack the housing.

Do not insert a foreign object, such as tweezers, into the connector mating contact portion. Doing so may cause the plating to peel off or deform the terminals.

### Precautions for Board Mounting

Be careful of the amount of board warping. If the board is excessively warped, soldering faults may occur.

### Storage

Do not store the connectors in locations subject to dust or high humidity. Do not store the connectors in locations close to sources of gasses such as ammonia gas or sulfide gas.

All sales are subject to Omron Electronic Components LLC standard terms and conditions of sale, which can be found at [http://www.components.omron.com/components/web/webfiles.nsf/sales\\_terms.html](http://www.components.omron.com/components/web/webfiles.nsf/sales_terms.html)

**ALL DIMENSIONS SHOWN ARE IN MILLIMETERS.**  
To convert millimeters into inches, multiply by 0.03937. To convert grams into ounces, multiply by 0.03527.

---

**OMRON**<sup>®</sup>

**OMRON ELECTRONIC  
COMPONENTS LLC**

55 E. Commerce Drive, Suite B  
Schaumburg, IL 60173

**847-882-2288**

**OMRON ON-LINE**

Global - <http://www.omron.com>

USA - <http://www.components.omron.com>