

2 SWITCHES & KNOBS

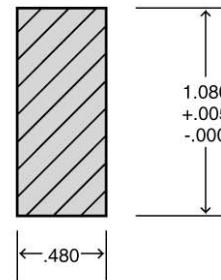

Panel Cut Out
Panel Thickness 1/32" - 3/16"

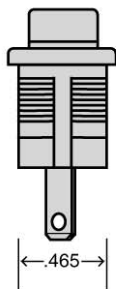
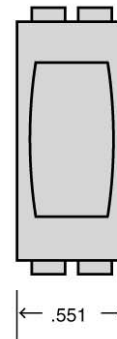
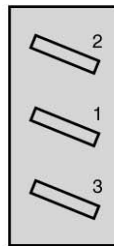
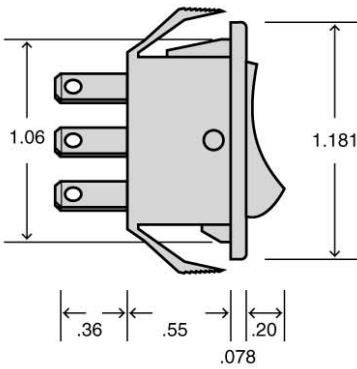
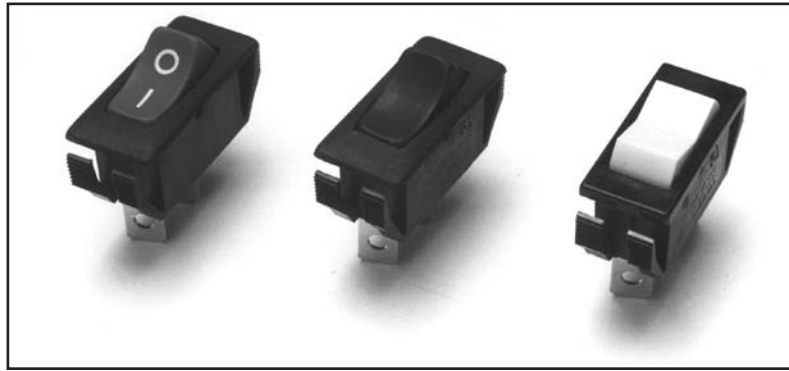