

### Standard Super Slide® Potentiometer

- **Features** Performance Standard of the Audio Industry  
 Ideal for TV / Audio / Video / Lighting Control / General Purpose Applications  
 Low Profile / High Performance / High Quality Tactile Feel

Type Potentiometer: Sxx1 Series

Size (Travel): 15, 30, 45, 60 mm

Product Series: 1

Number of Levers: 1

Number of Elements: 1

Style: X

Resistance Codes:  
 103 10kΩ  
 203 20kΩ  
 503 50kΩ  
 104 100kΩ

Tapers:  
 A Audio  
 B Linear

Lever Style: 4

Lever Length: L1 = 20 mm

Special Options: D, T

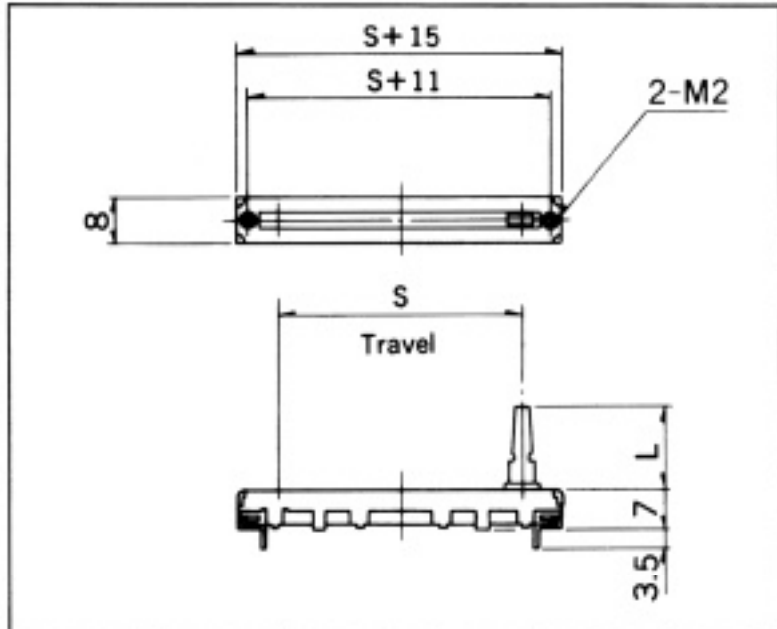

Mounting Height: H = 7 mm

### Standard Specifications:

Operation Force: 30 ~ 250 gf / cm

Resistance Tol.: ± 20%

Rated Power: 0.025 W

Max. Oper. Voltage: 50V AC  
 10V DC

Insulation Resistance:  
 100megΩ min @ 250 V DC

