

Contact blocks and lamp blocks with holder for front mounting

Max. number of blocks in holder	Included blocks	Catalog No.	Ref. Code
For non-illuminated operators			
3	1 NC	MCBH-01	1SFA 611 605 R1110
3	1 NO	MCBH-10	1SFA 611 605 R1101
3	2 NC	MCBH-02	1SFA 611 605 R1120
3	2 NO	MCBH-20	1SFA 611 605 R1102
3	3 NC	MCBH-03	1SFA 611 605 R1130
3	3 NO	MCBH-30	1SFA 611 605 R1103
3	1 NO + 1 NC	MCBH-11	1SFA 611 605 R1111
3	1 NO + 2 NC	MCBH-12	1SFA 611 605 R1121
3	2 NO + 1 NC	MCBH-21	1SFA 611 605 R1112

For illuminated operators			
3	1 NC + 1 LB	MCBH-011	1SFA 611 605 R1210
3	1 NO + 1 LB	MCBH-101	1SFA 611 605 R1201
3	1 NO + 1 NC + 1 LB	MCBH-111	1SFA 611 605 R1211
3	2 NC + 1 LB	MCBH-021	1SFA 611 605 R1220
3	2 NO + 1 LB	MCBH-201	1SFA 611 605 R1202

Single contact blocks for front mounting

Included blocks	Catalog No.	Ref. Code
1 NO	MCB-10	1SFA 611 610 R1001
1 NC	MCB-01	1SFA 611 610 R1010
1 NO with gold plated contacts	MCB-10G	1SFA 611 610 R1101
1 NC with gold plated contacts	MCB-01G	1SFA 611 610 R1110

Double contact block for front mounting

To be used together with MCBH5-00 when contact blocks in position 4- and 5- are needed.
Also when using MCBH-00 together with selector switch and contact block in position 3- is needed

Included blocks	Catalog No.	Ref. Code
2 NO	MCB-20	1SFA 611 610 R1002
2 NC	MCB-02	1SFA 611 610 R1020
1 NO + 1 NC	MCB-11	1SFA 611 610 R1011

Single lamp blocks for front mounting, Ba 9s base

Description	Catalog No.	Ref. Code
For max. 2 W, 230 V AC and DC filament bulb or LED	MLB-1	1SFA 611 620 R1001
115 V AC supply voltage. For 60 V filament bulb max. 1.2 W	MLB-2	1SFA 611 620 R1002
230 V AC supply voltage. For 130 V filament bulb max. 2 W	MLB-3	1SFA 611 620 R1003
115 V AC and DC supply voltage For 24 V LED	MLB-4	1SFA 611 620 R1004
24 V AC and DC supply voltage. With resistor. Intended for electronic circuits. The resistor limits the making current and protects against disturbances in the electronic circuit For 24 V filament bulb	MLB-5	1SFA 611 620 R1005

Holders

Description	Catalog No.	Ref. Code
Holders for front mounting		
For three blocks	MCBH-00	1SFA 611 605 R1100
For five blocks	MCBH5-00	1SFA 611 601 R1100

Contact blocks and lamp blocks for rear mounting See Page 8.43

Accessories

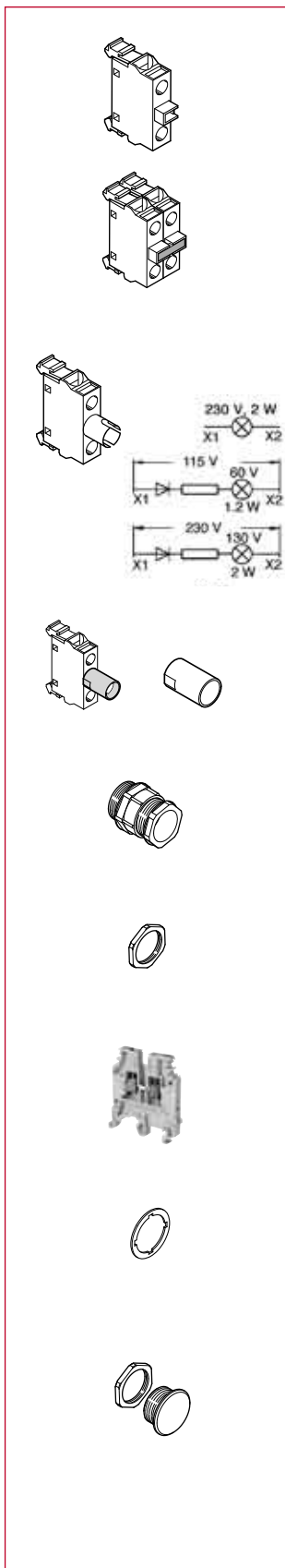

Contact blocks for rear mounting

Description	Catalog No.	Ref. Code
Contact block		
1NO	MCB-10B	1SFA 611 610 R2001
1NC	MCB-01B	1SFA 611 610 R2010

Double contact block

2NO	MCB-20B	1SFA 611 610 R2002
2NC	MCB-02B	1SFA 611 610 R2020
1NO+1NC	MCB-11B	1SFA 611 610 R2011

Contact block with gold plated contacts

1NO	MCB-10BG	1SFA 611 610 R2101
1NC	MCB-01BG	1SFA 611 610 R2110

Lamp blocks

For max. 2 W, 230 V AC and DC filament bulb or LED

115 V AC supply voltage.

For 60 V filament bulb max. 1.2 W

230 V AC supply voltage.

For 130 V filament bulb max. 2 W

	MLB-1B	1SFA 611 620 R2001
	MLB-2B	1SFA 611 620 R2002
	MLB-3B	1SFA 611 620 R2003

Protective sleeve

Description	Catalog No.	Ref. Code
To make a rear mounted lamp block screen protected. IP20	5396 0543-1	5396 0543-1

Earthing terminal

Description	Catalog No.	Ref. Code
For plastic enclosure.	MA5-2005	1SFA 611 925 R3005

Spacer

Description	Catalog No.	Ref. Code
1 mm thick. Needed when legend plates are not used in plastic enclosures.		
Spacer (Packing unit 10 pieces)	SK 615 516-1	SK 615 516-1
Spacer for Modular emergency stop pushbutton, page ?? (Packing unit 10 pieces)	KA1-8045	1SFA 616 920 R 8045

Blanking plug (22mm)

Description	Catalog No.	Ref. Code
Black plastic	SK 615 502-B	SK 615 502-B