

TV-5 Qualified Power Switch SDKL Series

Details

Product No.	Type	Circuit arrangement	Travel	Total travel	Operating force	Mounting method	Terminal style	Knob style	Minimum packing unit (pcs.)
SDKLA11000	Push	SPST	2.5mm	3.8mm	4.5±1.5N	φ3.2 hole	For PC board	Standard	100

Products Specifications

UL CSA	SEMKO	VDE	Ratings satisfying local electrical appliance and material safety law
TV-5 5A 250V AC	5A/80A 250V~μ	5A/80A 250V~μ	125V 10A ≠ 125V 5A ≠E

Operating temperature range	Ratings	Electrical performance		
		Contact resistance	Insulation resistance	Voltage proof
-10° C to +60° C	TV-5	100mΩ max.	500MΩ min. 500V DC	1,000V AC for 1 min.

Mechanical performance						
Robustness terminal	Robustness of actuator		Vibration	Solderability	Resistance to soldering heat	
	Operating direction	Perpendicular direction			Manual soldering	Dip soldering
10N for 1 min.	100N	20N	10 to 55 to 10Hz/min., the amplitude is 1.5mm for all the frequencies, in the 3 direction of X, Y and Z and for 2 hours respectively	230±5° C, 3±0.5s	350±10° C, 3±0.5s	260±5° C, 10±1s

Durability	Environmental performance		
Operating life	Cold	Dry heat	Damp heat
25,000 cycles Load: as ratings.	-20±2° C for 96h	85±2° C for 96h	40±2° C, 90 to 95%RH for 96h

1. "Microgap construction" defined in the IEC standard.
2. Place your purchase order in N minimum package units (N: integer).
3. Ask us for the export packaging unit.

Dimensions
For PC board

Unit : mm

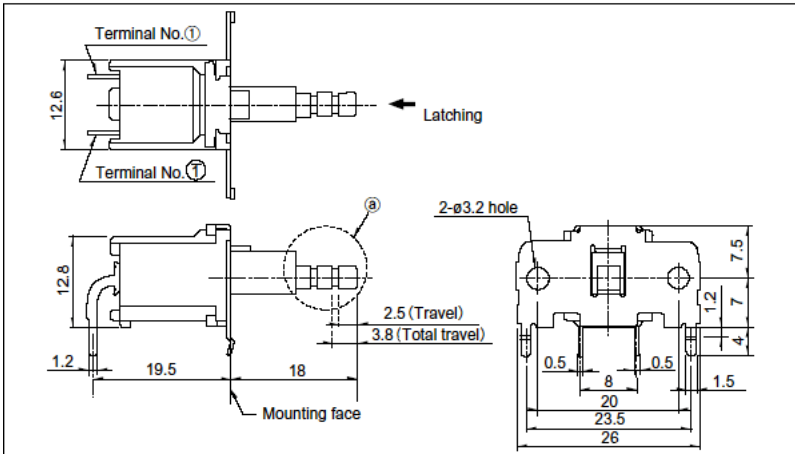

PC board Mounting Hole Dimensions

Unit : mm

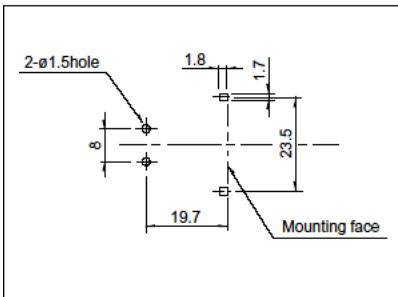

Operation Part Details of (a)

Unit : mm

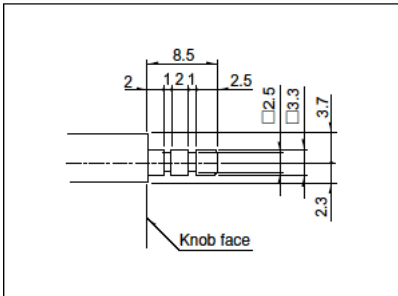

Circuit Diagram

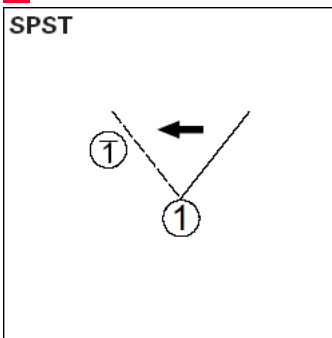

Attached Parts

Knob outline drawing (Unit: mm)	Color	Model
<p>Key pitch 10mm</p> <p>Square knob</p>	<p>Black</p> <p>Red</p> <p>White</p>	<p>4093-1</p> <p>4093-2</p> <p>4093-3</p>
<p>Key pitch 12.5mm</p> <p>Square knob</p>	<p>Black</p> <p>Red</p> <p>White</p>	<p>UE201011</p> <p>UE201012</p> <p>UE201013</p>
<p>Key pitch 15mm</p> <p>Square knob</p>	<p>Black</p> <p>Red</p> <p>White</p>	<p>UE202011</p> <p>UE202012</p> <p>UE202013</p>
<p>Key pitch 17.5mm</p> <p>Square knob</p>	<p>Black</p> <p>Red</p> <p>White</p>	<p>UE203011</p> <p>UE203012</p> <p>UE203013</p>
<p>Key pitch 20mm</p> <p>Square knob</p>	<p>Black</p> <p>Red</p> <p>White</p>	<p>UE204011</p> <p>UE204012</p> <p>UE204013</p>
<p>Round knob</p>	<p>Black</p> <p>Red</p> <p>White</p>	<p>UE200011</p> <p>UE200012</p> <p>UE200013</p>

● Notes When mounting the switch, it is recommended to secure the knob with an adhesive agent.

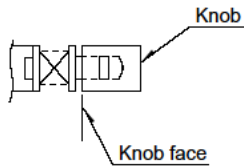

■ Safety Standards

1. Safety Standards Outline

Safety standards are established by a country or an organization representing it to protect general users from electrical shock and fire hazards.

It establishes standards for electrical devices and components. For electrical equipment manufacturers, utilizing switches that have been safety-approved ensures the safety of the switch. The use of a safety-approved switch also simplifies at least one part of the process of obtaining certification by safety testing.

2. Major Safety Standards

(1) Electrical Appliance and Material Control Law

The conventional [Electrical Appliance and Material Control Law] has changed to [Electrical Appliance and Material Safety Law] and has been enforced since April 1, 2001. Electrical appliances are categorized into special electric appliances and parts (formerly Class A) and Electrical appliances other than the special electric appliances (formerly Class B) .

Special electric appliances are required to receive goodness of fit test at a certified test agency and to store the certificate. Also, penal provisions have been reinforced.

(2) UL (Underwriters Laboratories Inc.)



Underwriters Laboratories Inc. (UL) is the American safety approving organization. Its purpose is to ensure consumer safety and protect them from fire hazards. State law requires that equipment to be exported to the United States utilize UL approved power switches or power switches meeting UL standards and capable of passing UL tests.

(3) CSA (Canadian Standards Association)



Canadian Standards Association (CSA) is the Canadian safety testing association and tests electrical and other equipment to ensure the safety of individuals and prevent fire hazards. Provincial law requires that the power switches used in equipment for export to Canada be CSA approved or meet CSA standards.

(4) SEMKO (Svenska Elektriska Materielkontrollanstalten)



Svenska Elektriska Materielkontrollanstalten (SEMKO) is the Swedish safety testing organization. Its purpose is to prevent electrical shock and fires due to home electrical appliances. Nearly all electrical appliances sold in Sweden must be approved by SEMKO.

(5) BS (British Standard)

British Standard (BS) is the industrial and safety standards of Great Britain. It is made up of such organizations as the BSI and BEAB. It conducts investigations of electrical equipment for verification of safety. Electrical devices do not have to conform to this standard but those that do have a competitive advantage in the marketplace.

(6) VDE (Verband Deutscher Electrotechniker)



Verband Deutscher Electrotechniker (VDE) is the German safety testing organization. It is particularly concerned with preventing hazards to human life and fires. Approval is not mandatory but fines are levied against those companies whose unapproved products cause accidents. Therefore, in reality, conformity is a necessity.

3. Standard Certification System

(1) CB Scheme

This is the international system to simplify the safety certification processes of each country for the purpose of using a safety test certificate (CB Scheme) based on the IEC standard issued by the certification test agency. This system can be used for the power switch to acquire the certificates of European countries and China because the IEC and EN standards conform.

(2) Mutual authentication system of the North American nations

A mutual authentication system is effective with the UL (in the U. S. A.) and CSA (in Canada) and the "C-UL-US" makes UL approved goods sellable in Canada, while the "NRTL/C" makes CSA approved goods sellable in the U. S. A.

4. Meaning of the Marking of Power Switch Ratings

Safety standard name Classification of rating	Electrical appliance and material safety law	UL, CSA	IEC standard
For electronic appliances	All Alps power switches are not governed by the electrical appliance and material safety law.	<p>TV rating</p> <p>TV - 5</p> <p>Rated current</p> <p>Symbol on TV rating</p> <p>NOTE : When not indicated rated voltage is 120V AC</p> <p>SDKL, SDDF, etc</p>	<p>Rating for electronic appliances</p> <p>5A / 80A 250V ~</p> <p>Rated surge current</p> <p>Rated voltage</p> <p>Rated normal current</p> <p>Alternating current</p> <p>SDKL, SDDF, etc</p>
For general appliances		<p>Ampere rating</p> <p>AC 125V 5A</p> <p>Rated current</p> <p>Rated voltage</p> <p>Alternating current</p> <p>SDDJE, etc</p>	<p>Rating for resistive appliance</p> <p>5A / 250V ~</p> <p>Rated current</p> <p>Rated voltage</p> <p>Alternating current</p>
For motors		<p>Horsepower rating</p> <p>AC 125V 1/2 HP</p> <p>Output of applicable motor</p> <p>Rated voltage</p> <p>Alternating current</p>	<p>Rating for resistance and motor load</p> <p>3(2) / 250 ~</p> <p>Rated current of applicable motor</p> <p>Rated current under resistive load</p> <p>Rating voltage</p> <p>Alternating current</p>

Power switches for electronic appliances

Mainly power switches for electronic appliances such as TV sets, radios and amplifiers. However, if the voltage and current levels are below the ratings, they may be used in other electric appliances.

Power switches for general appliances

These switches are for use in appliances other than electronic appliances or motor appliances that have current surges. However, if the rating of the switch is $1/\sqrt{2}$ or above the surge current of the circuit and meets construction requirements, it may be used in other devices.

Power switches for motor appliances

Mainly for appliances that are motor driven, such as copiers, vacuum cleaners, etc.

5. Explanation of Safety Standard Terms

1. Three insulation classes of the safety standards of IEC standards

Switches are classed according to their type of insulation.

(a) Switches for Class I Appliances

Switches for use with appliances utilizing power plugs with ground pins having a normal level of insulation.

(b) Switches for Class II Appliances

Switches for use with appliances having no ground pin and utilizing double or reinforced insulation.

2. Micro-gap Construction

This construction is one of the classifications of switches under the IEC standard. Switches in this class have a contact gap of less than 3mm. These switches bear the μ mark. In some case, use of Micro-gap switches may be limited in IEC standard. (Can not be utilized with outdoor electrical implements or computer equipments without electric plugs.)

3. Switches not covered in the Electrical Appliance and Material Control Law
Switches with [structure specialized for building into machines] are precluded from the special electric appliances and parts, and are not required to undergo a goodness of fit test. However, the technology standard must satisfy no less than the special electric appliances and parts. The major reasons for preclusion from the Electrical Appliance and Material Safety Law are as follows : All of our power switches are precluded.
 - (1) All except for unipolar/single-throw, unipolar/double-throw, bipolar/single-throw.
 - (2) All with signal changing-over switch attached.
 - (3) All with lead, faston, wire-wrapping and printed terminals.
 - (4) All without knobs and handles for manual operation.
4. Approval type number
The approval type number means the type number on the safety standard described in the safety standard approval certificate or approval list. Therefore, the approval type number is different from the product number. There are cases where the approval type number varies with the acquired standard, rating, etc. even in the same series of products. When the set manufacturer applies for the set safety standard, the application must be made with the approval type number for the switch to be used.

Caution

1. The primary power supply changeover is regulated by safety standards, and its contents vary for particular destinations. Consult with us for special applications.
2. An unstable contact may occur if the switch current is lower than 0.5A. For this case, consult with us.
3. These power switches were produced for alternating current. For direct current, consult with us.
4. Note that if the load is applied to the terminals during soldering they might suffer deformation and defects in electrical performance.
5. Use of water-soluble soldering flux shall be avoided because it may cause corrosion of the switch.
6. When soldering twice, wait until the first soldered portion cools to normal temperature. Continuous heating will deform the external portions, loosen or dislodge terminals, or may deteriorate their electrical characteristics.
7. Before soldering switches with locking mechanism, release the locks. If they are soldered without releasing the locks, the soldering heat may deform the locking mechanism.
8. Be sure to release the locks before removing the knobs. Otherwise, the locking mechanism may be broken.
9. Be sure to use the switch with forced travel positioned as close to the total travel as possible.
10. Tighten the mounting screws by applying the specified torque. Tightening with larger torque than the specified will result in malfunction or breakage of screws.
11. When corrosive gas is generated by peripheral material of a set using the switch, malfunctions such as imperfect contacts can occur. Be mindful of this point thoroughly in advance.
12. Storage method
 - (1) If you do not use the product immediately, store it just as delivered in the following environment : with neither direct sunshine nor corrosive gas and in normal temperatures. However, it is recommended that you should use it as soon as possible or within six months from the date of delivery at the most.
 - (2) After you break the seal, you should put the remainder in a plastic bag to shut out outside air, and store it in the same environment mentioned above. You should use it up as soon as possible.
 - (3) Do not stack too many switches for safety.

■ Measurement and Test Methods

[Rotational Torque (Operating Force)]

Measures the torque (operating force) necessary to rotate (move) the shaft (lever) . Unless otherwise specified, measurement shall be made at ambient temperatures of 5 to 35° C, the shaft rotational speed shall be 60° per second, and the lever traveling speed shall be 20mm per second.

[Withstand Voltage]

Applies AC voltage to the specified spot for a minute and then checks for arc, burning, dielectric breakdown and other abnormalities. Respective terminals may be tested as a group. The sections described below shall be tested unless otherwise specified. However, if the section concerned is so constructed as to conduct, that particular part shall not be tested.

[Insulation Resistance]

Applies specified voltage to the specified locations and then measures the insulation resistance with a megger. The locations described below shall be tested unless otherwise specified. However, if the section concerned is so constructed as to conduct, that particular part shall not be tested.

[Sections to be Tested for Withstand Voltage and Insulation Resistance]

- Between terminal and shaft(lever).
- Between terminal and metal cover(frame).

[Shaft (Lever) Strength against Push/Pull Actions]

Applies a specified force in the axial direction of the shaft (lever) for 10 seconds and then checks the operating part and other sections for deformation, breakage, operating condition, etc.

COPYRIGHT(C) 1995-2005 ALPS ELECTRIC CO.,LTD.