

A wide variety of detector switches available for various digital AV devices



Detector

Slide

Push

Rotary

Power

Dual-in-line  
Package Type

General-  
purpose Type

Water-proof  
Type

Fast Switching  
Type

### Typical Specifications

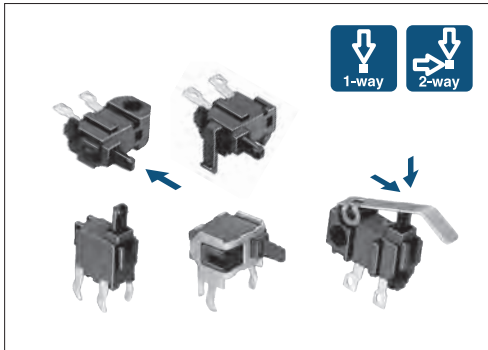

Items		Specifications
Rating (max.)/(min.) (Resistive load)		0.1A 30V DC / 50μA 3V DC
Contact resistance (Initial / After operating life)		1Ω max. / 2Ω max.
Operating force		0.35N max.
Operating life	Without load	50,000cycles
	With load	50,000cycles (0.1A 30V DC)

### Product Line

Poles	Positions	Operating part shape	Operating direction	Terminal type	Packaging style	Minimum order unit (pcs)		Product No.	Drawing No.
						Japan	Export		
1	1	Push	Horizontal	For Lead	Bulk	2,000	10,000	<b>SPPB110300</b>	1
								<b>SPPB120200</b>	2
								<b>SPPB310400</b>	7
								<b>SPPB320100</b>	8
		Actuator A	Horizontal	For PC board (Dip)	Bulk	1,000	5,000	<b>SPPB1A0100</b>	3
								<b>SPPB1A0101</b>	4
								<b>SPPB2A0100</b>	5
								<b>SPPB2A0101</b>	6
		Push	Vertical	For PC board (Dip)	Bulk	4,000	20,000	<b>SPPB512300</b>	9
								<b>SPPB610400</b>	13
		Actuator A	Horizontal	For PC board (Dip)	Bulk	2,000	10,000	<b>SPPB620300</b>	14
								<b>SPPB5A0100</b>	10
		Push	Vertical	For PC board (Reflow)	Taping	1,000	5,000	<b>SPPB6A0100</b>	15
								<b>SPPB6A0400</b>	16
								<b>SPPB530701</b>	11
								<b>SPPB530601</b>	12
Push	Horizontal	For PC board (Reflow)	Taping	1,300	5,200	<b>SPPB630101</b>	17		
						<b>SPPB640201</b>	18		

### Packing Specifications

Taping

Product No.	Number of packages (pcs.)			Tape width (mm)	Export package measurements (mm)
	1 reel	1 case /Japan	1 case /export packing		
<b>SPPB530701</b>	1,500	3,000	6,000	24	406×406×160
<b>SPPB530601</b>	600	1,200	2,400		
<b>SPPB630101</b> <b>SPPB640201</b>	1,300	2,600	5,200		

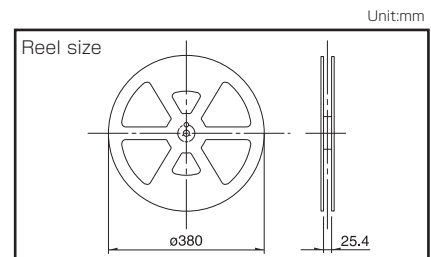





Bulk

Product No.	Number of packages (pcs.)		Export package measurements (mm)
	1 case /Japan	1 case /export packing	
<b>SPPB512300</b>	4,000	20,000	400×270×290
<b>SPPB1A0100, SPPB1A0101, SPPB2A0100, SPPB2A0101, SPPB5A0100, SPPB6A0100, SPPB6A0400</b>	1,000	5,000	
<b>SPPB310400, SPPB320100, SPPB610400, SPPB620300, SPPB110300, SPPB120200</b>	2,000	10,000	

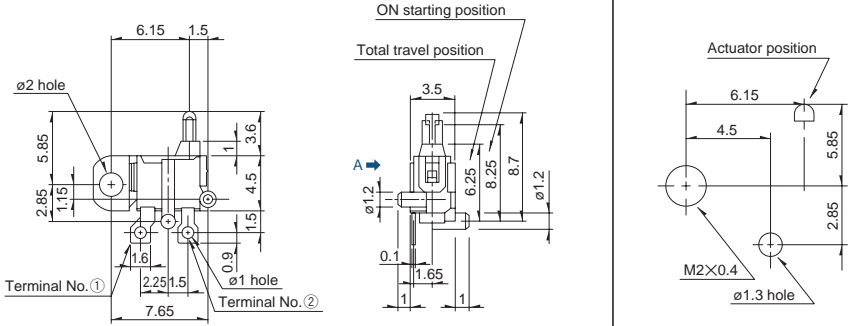
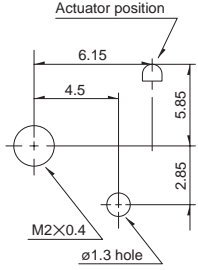
■ Dimensions

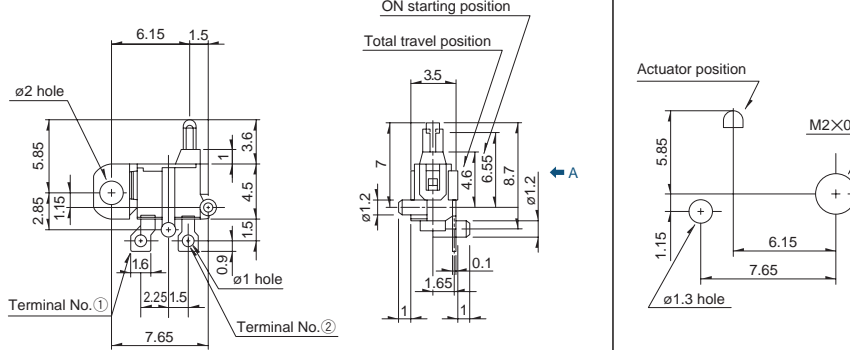
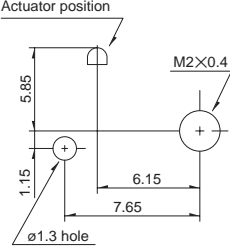
Unit:mm

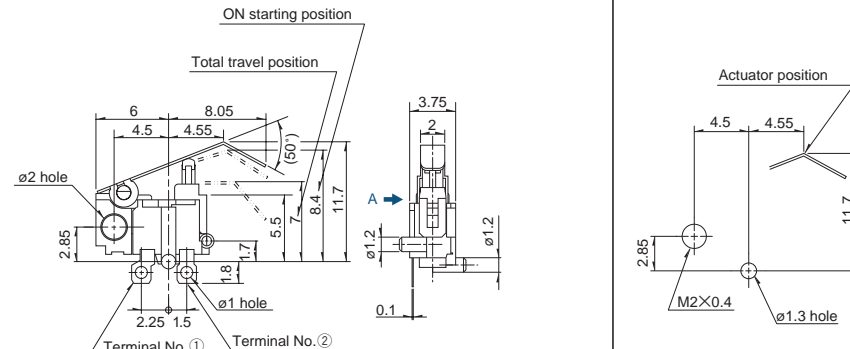
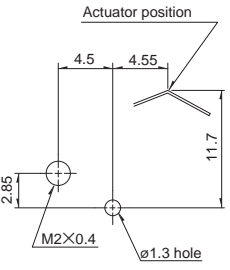
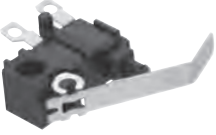
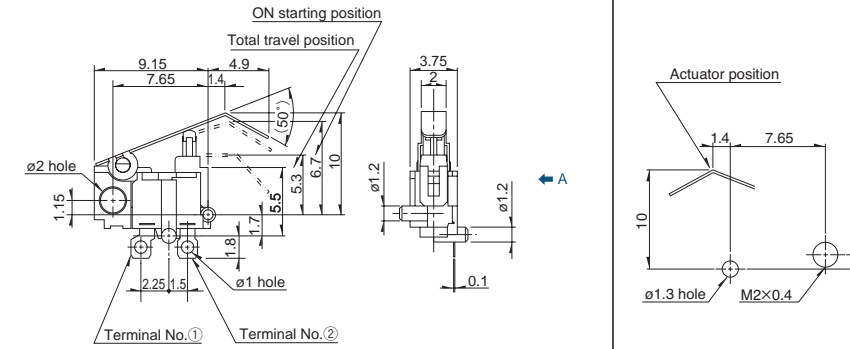
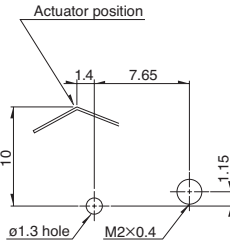
No.	Photo	Style	PC board mounting hole dimensions (Viewed from direction A)
1			
2			
3			
4			

Detector

Slide

Push

Rotary

Power

Dual-in-line  
Package Type

General-  
purpose Type

Water-proof  
Type

Fast Switching  
Type

## Dimensions

Unit:mm

No.	Photo	Style	PC board mounting hole dimensions (Viewed from direction A)
5			
6			
7			
8			





## Dimensions

Unit:mm

No.	Photo	Style	PC board mounting hole and land dimensions (Viewed from direction A)
13			
14			
15			
16			

■ Dimensions

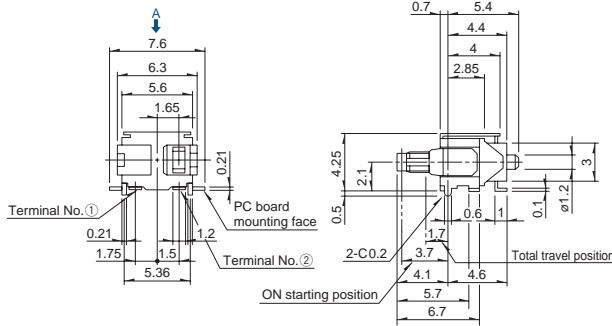
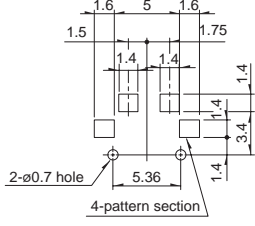
Unit:mm

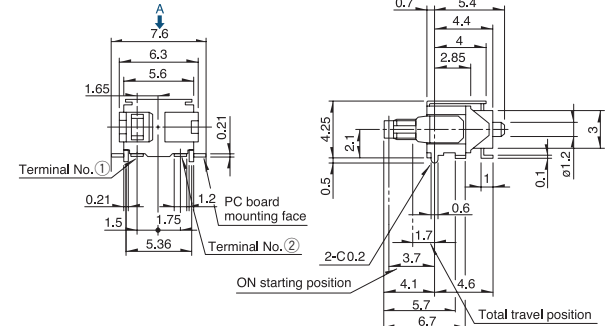
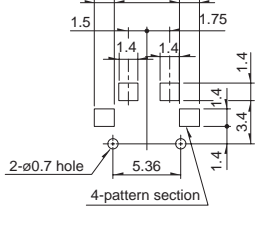
No.	Photo	Style	PC board mounting hole and land dimensions (Viewed from direction A)
17			
18			

■ Circuit Diagram (Viewed from Direction A)

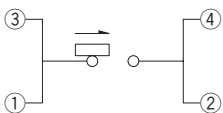
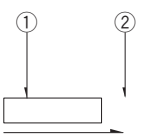
<p><b>Applicable to SPPB512300, SPPB530601, SPPB5A0100</b></p> 	<p><b>Applicable to other switches</b></p> 
--	--

Detector

Slide

Push

Rotary

Power

Dual-in-line  
Package Type







General-  
purpose Type

Water-proof  
Type

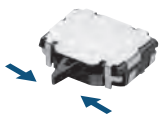
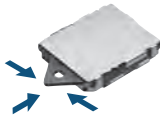
Fast Switching  
Type

# Detector Switches

## List of Varieties

Series		General-purpose Type			
		SSCQ	SSCM	SPVL	SPPB
Photo					
Operation type		Two-way Two-direction type	Two-way	Three-way	One-way Two-way
Dimensions (mm)	W	3.8	5	5.55	6.3
	D	3.6	4	6.6	3
	H	0.9	1.5	1	4.9
Operating temperature range		-10°C to +60°C		-40°C to +85°C	
Automotive use		—	—	●	●
Life cycle (availability)					
Poles / Positions		1 / Two-direction type: 2-position each side	1/2	1/1	
Rating (max.) (Resistive load)		1mA 5V DC			0.1A 30V DC
Rating (min.) (Resistive load)		50μA 3V DC			
Durability	Operating life without load	50,000cycles 5Ω max.			50,000cycles 2Ω max.
	Operating life with load Rating (max.) (Resistive load)	50,000cycles 5Ω max			50,000cycles 2Ω max.
Electrical performance	Initial contact resistance	2Ω max.			1Ω max.
	Insulation resistance	100MΩ min. 100V DC			
	Voltage proof	100V AC for 1 minute			
Mechanical performance	Terminal strength	0.5N for 1minute		1N for 1minute	3N for 1minute
	Actuator strength	1N	2N	5N	10N
Environmental performance	Cold	-20°C 96h		-40°C 500h	
	Dry heat	85°C 96h		85°C 500h	
	Damp heat	40°C, 90 to 95%RH 96h		60°C, 90 to 95%RH 500h	
Operation force		0.35N max.			
Page		29	30	31	32

Detector Switches Soldering Conditions	68
Detector Switches Cautions	69

### Note

- Indicates applicability to all products in the series.

# Detector Switches / Soldering Conditions

## Example of Reflow Soldering Condition

1. Heating method: Double heating method with infrared heater.
2. Temperature measurement: Thermocouple  $\phi 0.1$  to  $0.2$  CA (K) or CC (T) at soldering portion (copper foil surface).  
A heat resisting tape should be used for fixed measurement.
3. Temperature profile

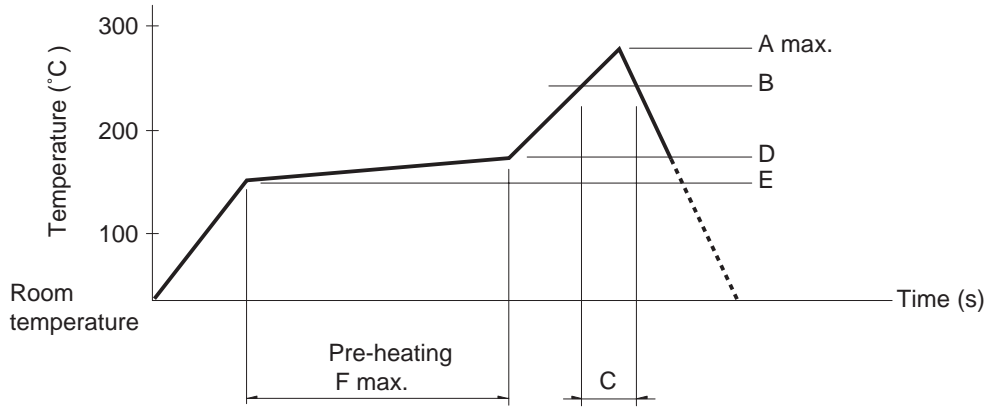

Series (Reflow type)	A (°C) 3s max.	B (°C)	C (s)	D (°C)	E (°C)	F (s)
<b>SPPB</b>	250	230	40	180	150	120
<b>SPVE</b>						
<b>SPVL</b>						
<b>SPVM</b>						
<b>SPVN</b>						
<b>SPVR</b>	260	230	40	180	150	120
<b>SPVS</b>						
<b>SPVT</b>						
<b>SSCM</b>	250	230	40	180	150	120
<b>SSCQ</b>						
<b>SPVQC</b>	250	230	40	180	150	120

### Notes

1. The condition mentioned above is the temperature on the mounting surface of a PC board. There are cases where the PC board's temperature greatly differs from that of the switch, surface depending on the PC board's material, size, thickness, etc.  
The above-stated conditions shall also apply to switch surface temperatures.
2. Soldering conditions differ depending on reflow soldering machines.  
Prior verification of soldering condition is highly recommended.

### Reference for Hand Soldering

Series	Soldering temperature	Soldering time
<b>SPVS, SPVN, SPVT, SPVM, SPVR, SPVE, SSCQ, SSCM, SPVL, SSCT, SPVQC</b>	350±5°C	3s max.
<b>SPVQ3, SPVQ6, SPVQ7, SPVQ8, SPVQ9, SSCN, SPVQA</b>	300±10°C	3 + 1 / 0s
<b>SPPB (Reflow)</b>	300±5°C	5s max.
<b>SSCF, SPPB (For Lead, Dip)</b>	350±10°C	3 + 1 / 0s

### Reference for Dip Soldering

(For PC board terminal types)

Series	Items		Dip soldering	
	Preheating temperature	Preheating time	Soldering temperature	Duration of immersion
<b>SSCT, SPVQ3, SPVQ6, SPVQ7, SPVQ8, SPVQ9, SPVQA</b>	100±10°C	60s max.	260±5°C	5±1s
<b>SPPW8, SPPB</b>	100 °C max.	60s max.	255±5°C	5±1s
<b>SSCF</b>	—		260±5°C	5±1s