

SSSS2 3.5(H)mm, 2mm-travel Type

Excellent application for designing compact and high density portable devices

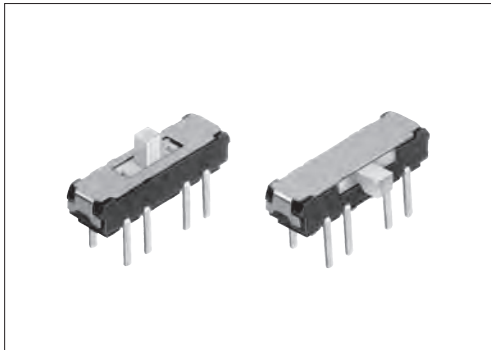

Typical Specifications

Items		Specifications
Rating (max.)/(min.) (Resistive load)		0.3A 6V DC / 50 μ A 3V DC
Contact resistance (Initial performance / After lifetime)		70m Ω max. / 130m Ω max.
Operating force		Refer to the dimensions.
Operating life	Without load	10,000 cycles*
	With load	10,000 cycles (0.3A 6V DC)*

Note * Operating life for SSSS213202 is 100 cycles

Product Line

Travel (mm)	Actuator direction	Actuator length (mm)	Poles	Positions	Changeover timing	Soldering	Minimum order unit (pcs.)		Products No.	Drawing No.	
							Japan	Export			
2	Vertical	2	1	2	Non shorting	Manual, Dip	2,000	10,000	SSSS213000	1	
				3					SSSS211900	2	
			2	2					SSSS222700	3	
				3					SSSS223600	4	
			1	2					SSSS213202	5	
				3					SSSS212901	6	
	4	SSSS213100		7							
	Horizontal	2	2	1		2	Manual, Dip	2,000	10,000	SSSS212200	8
						3				SSSS212400	9
						4				SSSS223200	10
				2		2				SSSS223900	11
						3				SSSS224100	12
						4				SSSS211603	13
				1		2				SSSS213800	14
						3				SSSS224500	15
2											

Packing Specifications

Taping

Product No.	Number of packages (pcs.)			Tape width (mm)	Export package measurements (mm)
	1 reel	1 case /Japan	1 case /export packing		
SSSS213202	1,200	2,400	4,800	24	428×413×172
SSSS212901	1,000	2,000	4,000		406×406×190
SSSS211603 SSSS213800 SSSS224500	1,400	2,800	5,600		

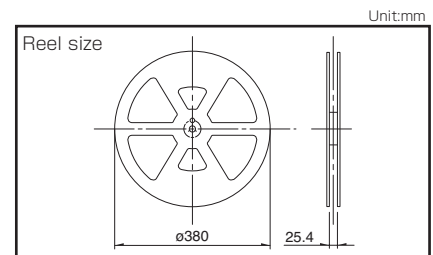

Bulk







Product No.	Number of packages (pcs.)		Export package measurements (mm)
	1 case /Japan	1 case /export packing	
SSSS211900, SSSS212200, SSSS212400, SSSS213000, SSSS213100, SSSS222700, SSSS223200, SSSS223600, SSSS223900, SSSS224100	2,000	10,000	400×270×290

SSSS2 3.5(H)mm, 2mm-travel Type

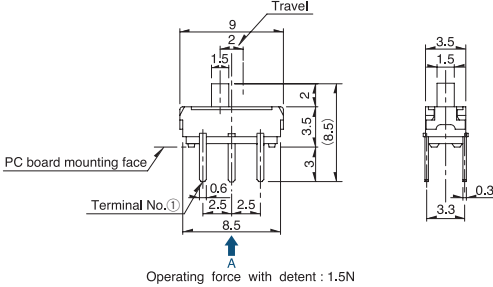
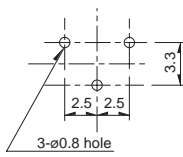
■ Dimensions

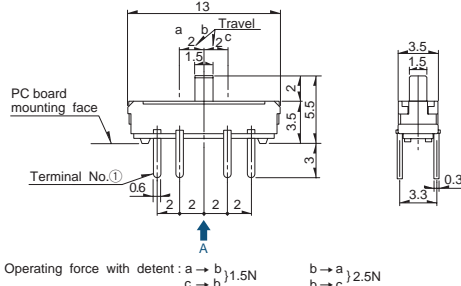
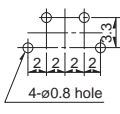
Vertical Actuator Type

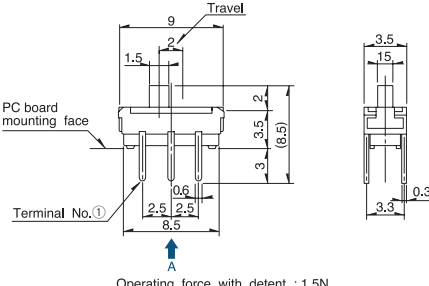
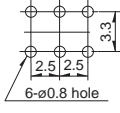

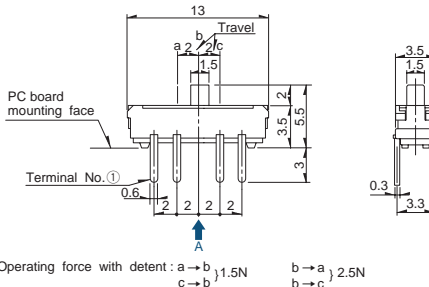
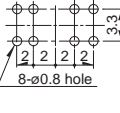
Unit:mm

No.	Photo	Style	PC board mounting hole dimensions (Viewed from direction A)
1			
2			
3			
4			

■ Dimensions

Vertical Actuator Type/Horizontal Actuator Type

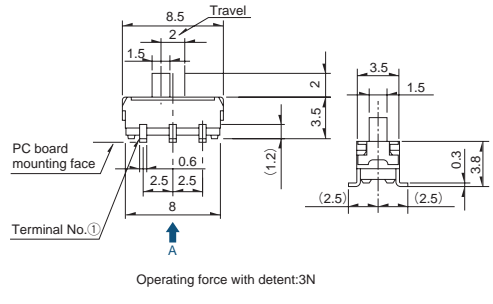
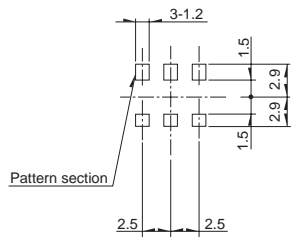
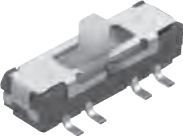
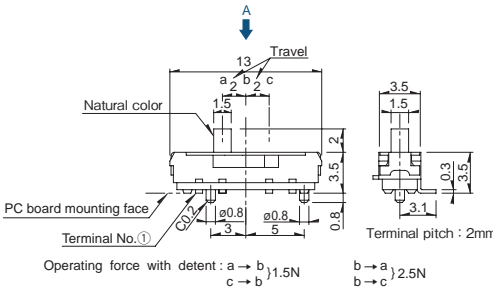
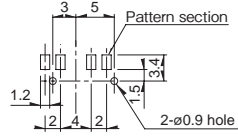
Unit:mm

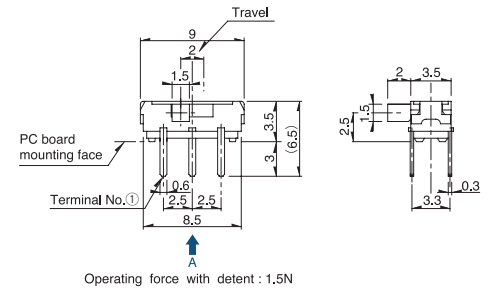
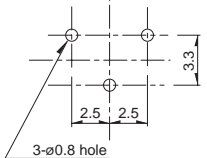
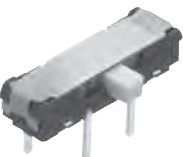
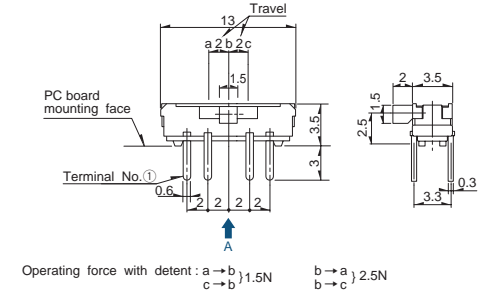
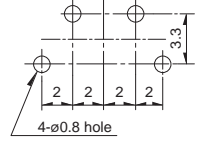
No.	Photo	Style	PC board mounting hole dimensions (Viewed from direction A)
5		 <p>Operating force with detent:3N</p>	 <p>Pattern section</p>
6		 <p>Operating force with detent : a → b } 1.5N b → a } 2.5N c → b } 1.5N b → c } 2.5N</p>	 <p>Pattern section</p>
7		 <p>Operating force with detent : 1.5N</p>	 <p>3-ø0.8 hole</p>
8		 <p>Operating force with detent : a → b } 1.5N b → a } 2.5N c → b } 1.5N b → c } 2.5N</p>	 <p>4-ø0.8 hole</p>

Detector
 Slide
 Push
 Rotary
 Power
 Dual-in-line Packages Type
 Small size General Use Type
 Big size General Use Type

SSSS2 3.5(H)mm, 2mm-travel Type

Detector

Slide

Push

Rotary

Power

Dual-in-line
Packager Type



Small size
General Use Type

Big size
General Use Type

Dimensions

Horizontal Actuator Type

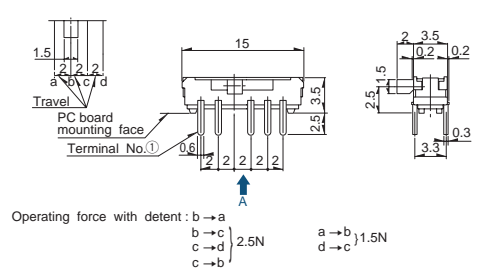
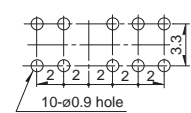
Unit:mm

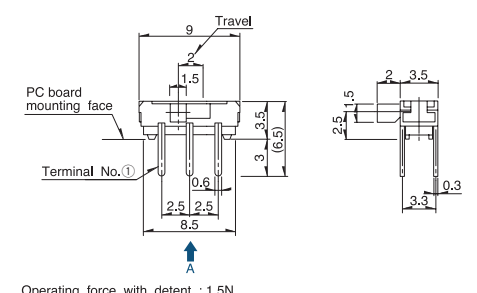
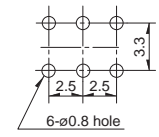
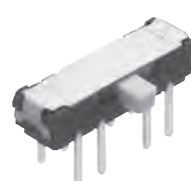
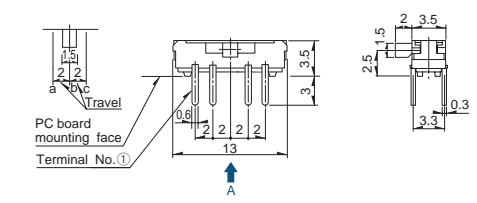
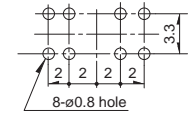
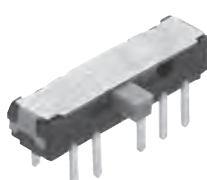
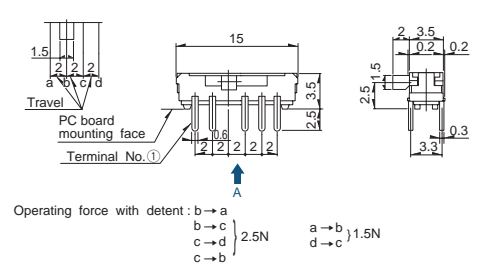
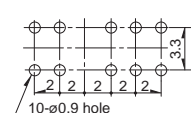
No.	Photo	Style	PC board mounting hole dimensions (Viewed from direction A)
9		 <p>Operating force with detent : b → a b → c c → d c → b } 2.5N a → b } 1.5N d → c }</p>	 <p>10-ø0.9 hole</p>
10		 <p>Operating force with detent : 1.5N</p>	 <p>6-ø0.8 hole</p>
11		 <p>Operating force with detent : a → b } 1.5N b → a } 2.5N c → b } b → c }</p>	 <p>8-ø0.8 hole</p>
12		 <p>Operating force with detent : b → a b → c c → d c → b } 2.5N a → b } 1.5N d → c }</p>	 <p>10-ø0.9 hole</p>

■ Dimensions











Horizontal Actuator Type/Reflow Type

Unit:mm

No.	Photo	Style	PC board mounting hole and land dimensions (Viewed from direction A)
13		<p>1-pole, 2-position</p> <p>Operating force with detent : 1.5N</p>	
14		<p>1-pole, 3-position</p> <p>Operating force with detent : a → b, c → b } 1.5N b → a, b → c } 2.5N</p>	
15		<p>2-pole, 3-position</p> <p>Operating force with detent : a → b, c → b } 1.5N b → a, b → c } 2.5N</p>	

■ Circuit Diagram (Viewed from Direction A)

<p>1-pole, 2-position Drawing No.1, 5, 7</p>	<p>1-pole, 3-position Drawing No.2, 6, 8</p>	<p>2-pole, 2-position Drawing No.3, 10</p>
<p>2-pole, 3-position Drawing No.4, 11, 15</p>	<p>1-pole, 4-position Drawing No.9</p>	<p>2-pole, 4-position Drawing No.12</p>
<p>1-pole, 2-position Drawing No.13</p>	<p>1-pole, 3-position Drawing No.14</p>	

Series		SSSS2※	SSSS9	SSAC	SSSF	SSSU
Photo						
Actuator direction	Horizontal	●	●	●	●	●
	Vertical	●	●	—	●	●
Poles-positions	1-2	●	●	—	●	●
	1-3	●	●	—	●	●
	1-4	●	—	—	—	—
	2-2	●	●	●	●	●
	2-3	●	●	●	●	●
	2-4	●	—	—	—	—
	4-2	—	—	—	●	●
Travel (mm)		2	2	1.5	2	3
Operating temperature range		-40°C to +85°C		-10°C to +60°C	-40°C to +85°C	
Automotive use		—	—	—	—	—
Life cycle						
Rating (max.) (Resistive load)		0.3A 6V DC	0.1A 12V DC	1mA 5V DC	0.1A 30V DC	
Rating (min.) (Resistive load)		50μA 3V DC	1mA 5V DC	50μA 3V DC		
Durability	Operating life without load	10,000 cycles 100mΩ max.※	10,000 cycles 60mΩ max.	10,000 cycles 200mΩ max.	10,000 cycles 45mΩ max.	
	Operating life with load Load: as rating	10,000 cycles 130mΩ max.※	10,000 cycles 80mΩ max.		10,000 cycles 65mΩ max.	
Electrical performance	Initial contact resistance	70mΩ max.	30mΩ max.	100mΩ max.	25mΩ max.	
	Insulation resistance	100MΩ min. 500V DC		100MΩ min. 100V DC	100MΩ min. 500V DC	
	Voltage proof	500V AC for 1minute		100V AC for 1minute	500V AC for 1minute	
Mechanical performance	Terminal strength		3N for 1minute		5N for 1minute	
	Actuator strength	Operating direction	20N	30N	5N	30N
		Pulling direction	10N			
Environmental performance	Cold	-20°C 500h	-40°C 500h	-20°C 96h	-40°C 500h	
	Dry heat	85°C 500h		85°C 96h	85°C 500h	
	Damp heat	60°C, 90 to 95%RH 500h		40°C, 90 to 95%RH 96h	60°C, 90 to 95%RH 500h	
Page		85	90	96	98	102

Slide Switches Soldering Conditions	106
Slide Switches Cautions	107

Notes

- ※ Operating life for SSSS213202 is 100 cycles.
- Indicates applicability to all products in the series.

Example of Reflow Soldering Condition

1. Heating method: Double heating method with infrared heater.
2. Temperature measurement: Thermocouple ϕ 0.1 to 0.2 CA (K) or CC (T) at soldering portion (copper foil surface).
A heat resisting tape should be used for fixed measurement.
3. Temperature profile

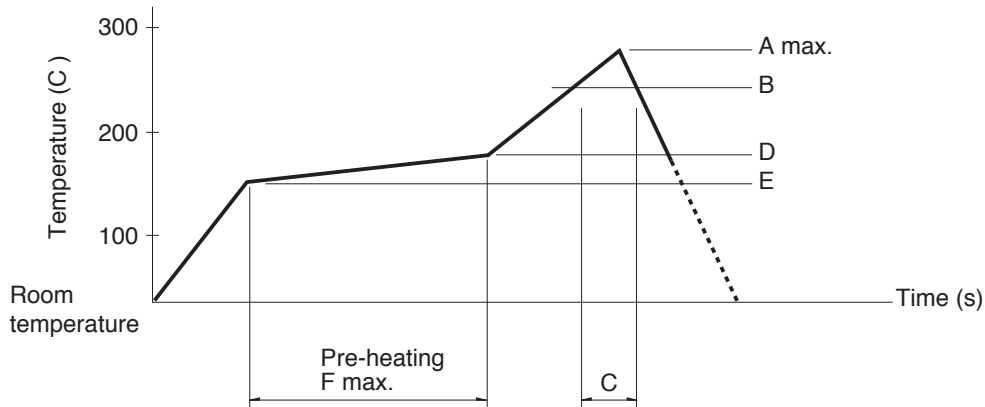

Series (Reflow type)		A (°C) 3s max.	B (°C)	C (s)	D (°C)	E (°C)	F (s)
SSSS2	Vertical 1-pole, 3-position	260	230	40	180	150	120
	Horizontal 1-pole, 2-position 1-pole, 3-position 2-pole, 3-position						
	Vertical 1-pole, 2-position	250					
SSAG, SSAJ, SSAL, SSSS8, SSS7		260					

Notes

1. The condition mentioned above is the temperature on the mounting surface of a PC board. There are cases where the PC board's temperature greatly differs from that of the switch, depending on the PC board's material, size, thickness, etc. The above-stated conditions shall also apply to switch surface temperatures.
2. Soldering conditions differ depending on reflow soldering machines. Prior verification of soldering condition is highly recommended.

Reference for Hand Soldering

Series	Soldering temperature	Soldering time
SSSF, SSSU	350±10°C	3+1/0s
SSSS2	350±10°C	4s max.
SSSS9	350±10°C	3s max.
SSAG, SSAJ, SSAL	350±5°C	3s max.
SSSS8	330±5°C	3s max.
SSSS7	320±5°C	3s max.
SSAC	300±10°C	2s max.

Reference for Dip Soldering

(For PC board terminal types)

Series	Items		Dip soldering	
	Preheating temperature	Preheating time	Soldering temperature	Duration of immersion
SSSS2	100°C max.	60s max.	260±5°C	3±1s
SSSS9	120°C max.	60s max.	260±5°C	5+0/-1s (2 times)
SSSF, SSSU	100°C max.	60s max.	260±5°C	10±1s/5±1s
SSAC	100°C max.	60s max.	260±5°C	5±1s