



Features:

- Universal Input 100 – 240 VAC
- Power Density: 6.25 watts/cu inches
- 2 VDC – 60 VDC Output
- Over-Current Protection
- Over-Voltage Protection
- Peak Power 700W within 500uS duty duration
- 3 Mechanical Options
- Optional N+1 Forced Active Current Sharing



Input Voltage: 90-264 VAC full range, 47~63Hz.

Input Current: 6.35A at 90 VAC full load.

Inrush Current: 35A Max @ 230 VAC with full load and cold start.

PFC: Active power factor correction meet EN61000-3-2 class D.

Fan Drive: 12VDC/400mA is available to drive an external fan.

Transient Response: Returns to within 1% in less than 2.5mS for a 50% load change and the peak transient does not exceed 5%.

Overshoot: Turn-on/off not exceed 5% over nominal voltage.

Efficiency: 70% for 3.3V, 75% for 5V, 80% for 12V and 83% minimum for others output @ 230 VAC and full load.

Turn On Delay: 1 second maximum at 120 VAC.

Hold Up Time: 20mS min. at 80% of full load.

Adjustability: Output user adjustable $\pm 5\%$ minimum.

Remote Sense: Designated **RS+** and **RS-** on the CN3. (Not available for current sharing models)

Remote On-Off: Designated as **RSW** on the CN3, requires a low signal to inhibit output.

Power Supply On: Green LED designated as **LED 1** on the PCB.

LED display: Bi-color green **LED** in front panel (SDE400T2R1 only); Any protection occurred or RSW applied low signal will emit orange.

Power Good: Designated as **PG** on the CN3 will go high 100-500mS after regulation and goes low 1mS before loss of regulation.

Current Sharing: Designated as **CSH** on the CN3, optional single wired for forced current sharing function and parallel up to 4 units within 10% accuracy at full load.

Current Monitor: Designated as **CMN** on the CN3 for current sense for a 0.5V to 3VDC to represent 0% to 100% output current.

Margin: Designated as **MAG** on the CN3 providing 50% of output voltage remote adjustment by applying 0.4 ~ 5V signal on **MAG**.

AC Fail (optional): Designated as **ACF** on the CN3 to monitor the input voltage, when input goes under 80 ± 5 VAC the signal will go low (0V) and then go high (+5V) once reappears over 86 VAC.

Input Circuit Protection (primary): Two T8A/250V fuses inserted.

Over-Power Protection: C.C. mode 110-140% and auto-recovery.

Input Voltage Protection: Power shut down under 80 ± 5 VAC, and recovered over 86 VAC.

Over-Voltage Protection: Latching down will occur when output voltage exceed 130% and recycle AC input to reset.

Short Circuit Protection: Trip without damage and auto-recovery.

Over Temperature Protection: Protected in the event of excessive operating ambient 85°C, and automatic recovery.

Switching Frequency: 30KHZ fixed frequency.

Operating Temperature: 0 to 70°C ambient, de-rating at 2.5% per degree from 50°C to 70°C.

Storage Temperature: -20 to 85°C.

Operating Humidity: 5% to 90% RH, Non-condensing.

Storage Humidity: 5% to 95% RH, Non-condensing.

Vibration: Frequency 5 to 50 Hz, acceleration ± 7.35 M/(SxS) on X, Y and Z Axis.

Emissions: FCC Part 15, CISPR 22 class B, Conducted.

Safety Regulation: Approved to UL60950-1, CSA C22.2 No. 60950-1-03, TUV EN60950-1, CE Mark (LVD) EN61204-3/61000-3-2,3 & IEC61000-4 Series Regulations and CB.

Leakage Current: 1.5mA.

HI-POT Test: 1500 VAC between input line and chassis (2mA DC cut off current); 4000 VAC between primary and secondary windings; Primary to core 1500 VAC. All for 3 sec.

Grounding Test: Apply 40A from ground pin to the earthed connection point. Maximum allowable resistance is 0.1ohm.

MTBF: 100,000 Hrs (according to MIL-HBK-217F) at 30°C.

Cooling: SDU400T2R1 Series: U-Chassis @ 400W max. with 23CFM airflow or 250W max. under convection cooling. SDE400T2R1 Series: Enclosed with side built-in fan @ 400W max.

Burn in: 45 ± 5 °C for 1 hour @ 230 VAC with full load.

Enclosure: SDU400T2R1 Series: 8(L) x 5(W) x 1.6(H) inches. SDE400T2R1 Series: 9(L) x 5(W) x 1.6(H) inches.

Weight: SDU400T2R1 Series: 1.3KG; SDE400T2R1 Series: 1.6KG.



SDY400T2R1 Series

Single Output, Switch Mode Power Supply
Active PFC, RoHS Compliant

Date: 8/25/09

Rev: 082809

Page: 2 of 5

Output Voltage and Current Chart

Model Number**	Preset Voltage	Output Voltage	Max. Output Power/Current		Efficiency	Ripple & Noise
			Type <u>U</u> (Forced Air) & Type <u>E</u>	Type <u>U</u> & <u>C</u> (Convection)		
SDY400T2R1XXR	3.3 VDC	2 - 3.3 VDC	60 A	45 A	70%	±1%
SDY400T2R1XXR	5 VDC	5 - 6 VDC	60 A	45 A	75%	±1%
SDY400T2R1XXR	12 VDC	12 - 15 VDC	400W	250W	80%	±1%
SDY400T2R1XXR	18 VDC	16 - 21 VDC	400W	250W	83%	±1%
SDY400T2R1XXR	24 VDC	12 - 30 VDC	400W	250W	83%	±1%
SDY400T2R1XXR	36 VDC	31 - 41 VDC	400W	250W	83%	±1%
SDY400T2R1XXR	48 VDC	42 - 58 VDC	400W	250W	83%	±1%

** To Determine Part Number:

- Replace "XX" with Required Output Voltage (5VDC = "05", 12VDC = "12", 48VDC = "48", ect.)
 - Replace "Y" with Desired Case Code:
 - Type U: U-Chassis @ 400 Watts Max. Output Power with 23 CFM Airflow or 250 Watts Convection Cooling
 - Type C: U-Chassis with Cover @ 400 Watts Max. Output Power with 23 CFM Airflow or 250 Watts Convection Cooling
 - Type E: Enclosed with Side Built-In Fan @ 400 Watts Max. Output Power
 - Conformal Coating (Optional): Order as SDY400T2R1XXCR
 - Current Sharing N+1 Redundancy (Optional): Order as SDY400T2R1XXRN
 - Input Connector: For Enclosure w. Fan (SDE400T2R1XXR): IEC320-C14 Inlet or 3-Position Barrier Strip.
For U-Channel (SDU400T2R1XXR) & Cover (SDC400T2R1XXR): Crimp Style PCB Header (7-Pin, 5 Used or 3-Position Barrier Strip.
 - Output Connector: 16-Pin Crimp Style PCB Header or 6-Position Barrier Strip.
For Crimp Style PCB Header (or IEC320-C14 Input), Order as: SDY400T2R1XXR (Unchanged)
For 4-Position Barrier Strip, Order as: SDY400T2R1XXAR
- Example: SDE400T2R124R indicates a 24VDC Unit with an Enclosed, Side Fan Case and Crimp Style PCB Header.
- SDC400T2R148ACR indicates a 48VDC Unit with U-Chassis Case with Cover, 6-Position Barrier Strip, and Conformal Coating.



TECHNOLOGIES INC.
HICKSVILLE, NEW YORK

264 Duffy Avenue
Hicksville, NY 11801

Tel: (516) 433-1313
Fax: (516) 433-1457

Web: www.apxonline.com
Email: sales@apxonline.com

© Copyright 1978
APX Technologies, Inc.



SDY400T2R1 Series

Single Output, Switch Mode Power Supply
Active PFC, RoHS Compliant

Date: 8/25/09

Rev: 082809

Page: 3 of 5

Pin Connection: SDY400T2R1XXR

Pin	Input: 7-Pin Crimp Terminal
1-2	Line
3	No Connection
4-5	Neutral
6	No Connection
7	Ground
Pin	Output: 16-Pin Crimp Terminal
1-8	V Output (+)
9-16	Return (-)

Pin Connection: SDY400T2R1XXAR

Pin	6-Position Barrier Strip
1-3	V Output (+)
4-6	Return (-)

Notes:

Input Connector(CN1):

SDU400T2R1 or SDC400T2R1 Series: mating Molex Part No. 09-91-0700 equivalent(7 pin, 5 used), or Howder Terminal block Part No. HD-121-3P.

SDE400T2R1 Series: IEC320 or equivalent Snap-in mounting type or DINKLE Terminal block Part No. DT-35-A02W-03 (3 pin).

Output Connector (CN2): Mating Molex 16 pins (09-91-1600), or Howder (HD-121-6P) M3.5, 8 pins terminal block, 9.5MM Center.

Output Pin Assignment: (See right table).

Logic signal connectors (CN3): Mating JST XHP-9 or equivalent (CHYAO SHIUNN JS-2001-09) Mating Pins: JST SXH-002T-P0.6 for AWG 30 to 26.

Mounting Inserts: 6-32, M4 4 Places individually with maximum penetration 0.15 inches on bottom side and 0.25 inch on both side.



TECHNOLOGIES INC.
HICKSVILLE, NEW YORK

264 Duffy Avenue
Hicksville, NY 11801

Tel: (516) 433-1313
Fax: (516) 433-1457

Web: www.apxonline.com
Email: sales@apxonline.com

© Copyright 1978
APX Technologies, Inc.



SDY400T2R1 Series

Single Output, Switch Mode Power Supply
Active PFC, RoHS Compliant

Date: 8/25/09

Rev: 082809

Page: 4 of 5

Type **U**: U-Chassis Case
Order as: SD**U**400T2R1XXR

Type **C**: U-Chassis Case w/ Cover
Order as: SD**C**400T2R1XXR

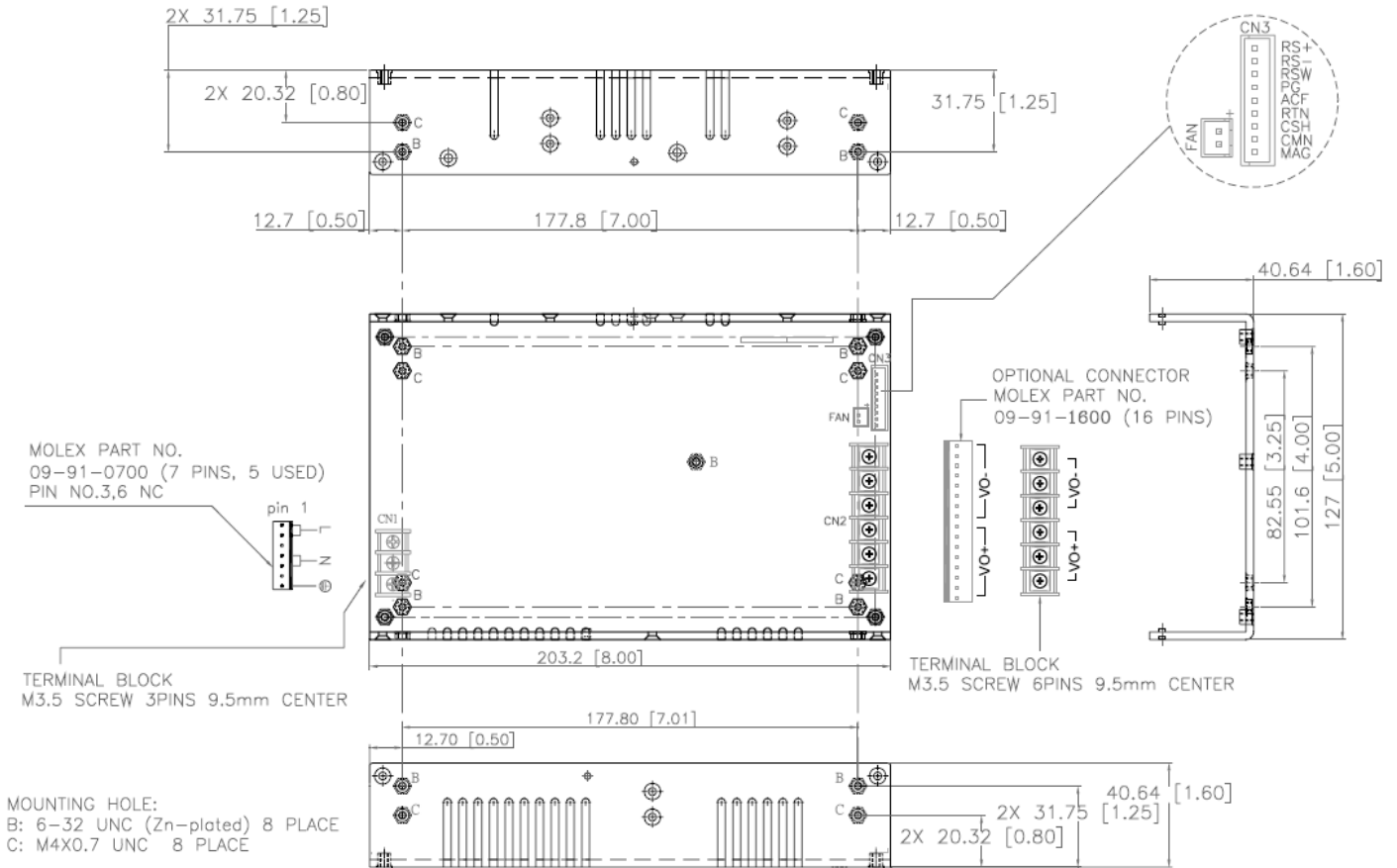
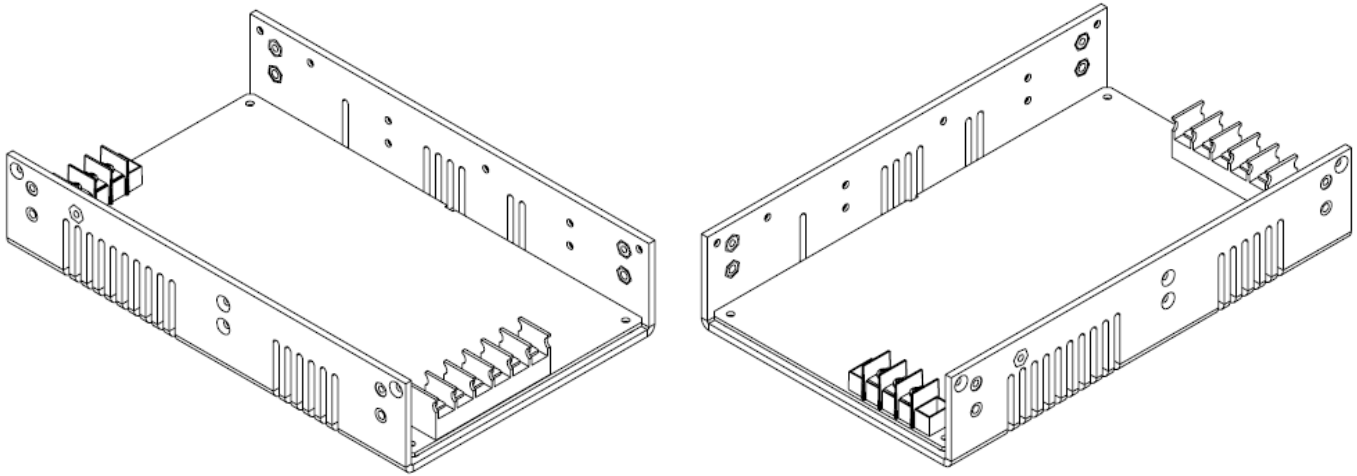

TECHNOLOGIES INC.
HICKSVILLE, NEW YORK

264 Duffy Avenue
Hicksville, NY 11801

Tel: (516) 433-1313
Fax: (516) 433-1457

Web: www.apxonline.com
Email: sales@apxonline.com

© Copyright 1978
APX Technologies, Inc.

Type **E**: Enclosed Case w/ Side Fan
Order as: SDE400T2R1XXR

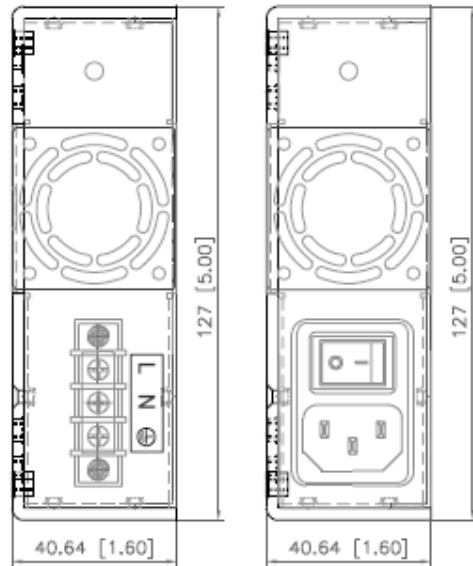
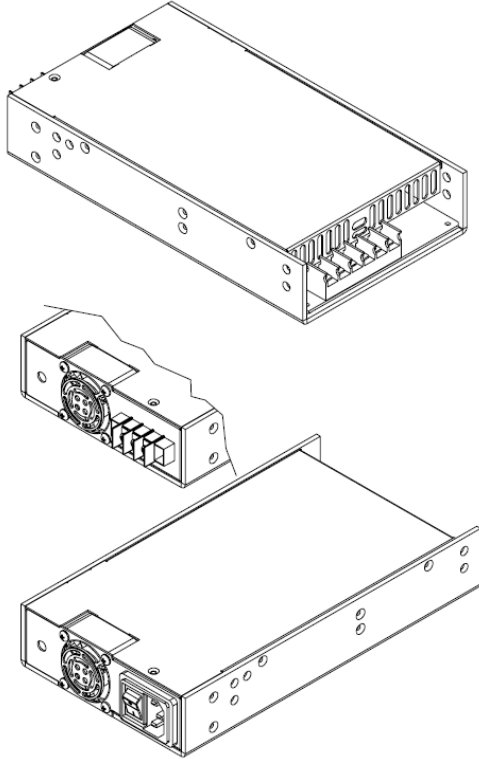

TERMINAL BLOCK
M3 SCREW
3PINS 8.25mm CENTER

