

Comus Group of Companies

PRODUCT DATA SHEET

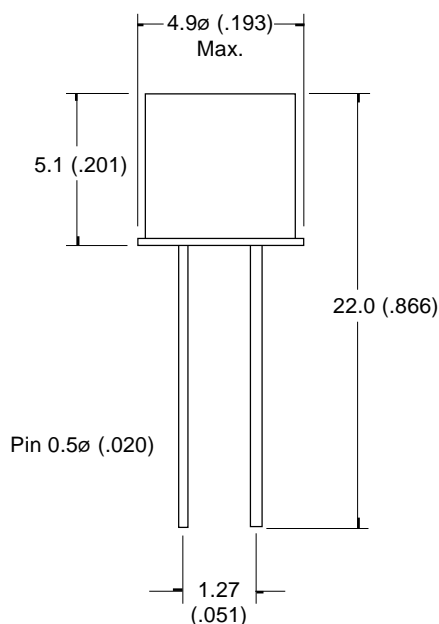

Drawings not to scale
All dimensions in mm (inches) nominal

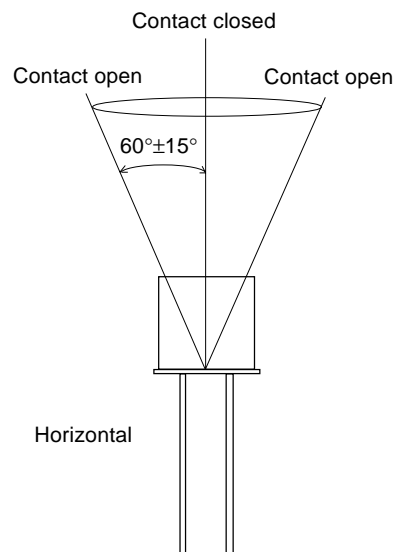

Tip-Over Switches operate when the switch is tilted from the vertical position. The angle through which the switch has to move before operating is called the operating angle. These switches are plane only.

SPECIFICATION

CONTACT FORM/STYLE		Normally Closed
SWITCHING VOLTAGE	Max. Vac	120
SWITCHING CURRENT	Max. A	.10A at 240 Vac / .25A at 120 Vac
SWITCHING CAPACITY	Max. VA	-
CONTACT RESISTANCE	Max. Ω	3
OPERATING ANGLE	Max. Deg°	60° ± 15°
OPERATING TEMPERATURE	Deg. °C	-37° + 100°
STORAGE TEMPERATURE	Deg. °C	-40° + 125°
CASE MATERIAL		Steel-tin plated
CABLE / TERMINATION		Pin
FEATURES		Miniature

NOTE: When cutting or bending switch leads it is important that the glass seal is not damaged. The cutting or bending point should be no closer than 3mm (.118) to the glass to metal seal and the lead should be supported between the cutting or bending point and the glass to metal seal.

TIP-OVER SWITCH - Metal - Mercury Contacts

PART NUMBER
CM 1365-0

Rev. No.	Revision Note	Date	Signature
C	Web Site 2005	1-3-01	RG

The Comus Group of Companies consist of:
Assemtech Europe Limited
Comus International
Comus Belgium
Gunther France
S.T.G.

As part of the company policy of continued product improvement, specifications may change without notice. Our sales office will be pleased to help you with the latest information on this product range and details of our full design and manufacturing service. All products are supplied to our standard conditions of sale otherwise agreed in writing.