

# VERTICAL EB700

## 5mm SPACING, CAGE CLAMP, MINI BLOCKS

### TECHNICAL DATA

#### MECHANICAL

**Torque:**

4.0 lbs-in Max.

**Operating temperature:**

-33°C to +120°C

-27°F to +248°F

**Soldering temperature:**

260°C, 500°F for 5 seconds max

#### MATERIAL

**Contact:**

Brass, Nickel Plated

**Contact Solder Pin:**

Brass, Tin Plated

**Screw:**

M3, Steel, Zinc Plated

**Insulator body:**

Polyamide, UL 94V-0, Blue

#### ELECTRICAL

**Voltage rating:**

300VAC

**Current rating:**

20 Amps

**Wire Range:**

12-22AWG

### DIMENSIONAL REFERENCE

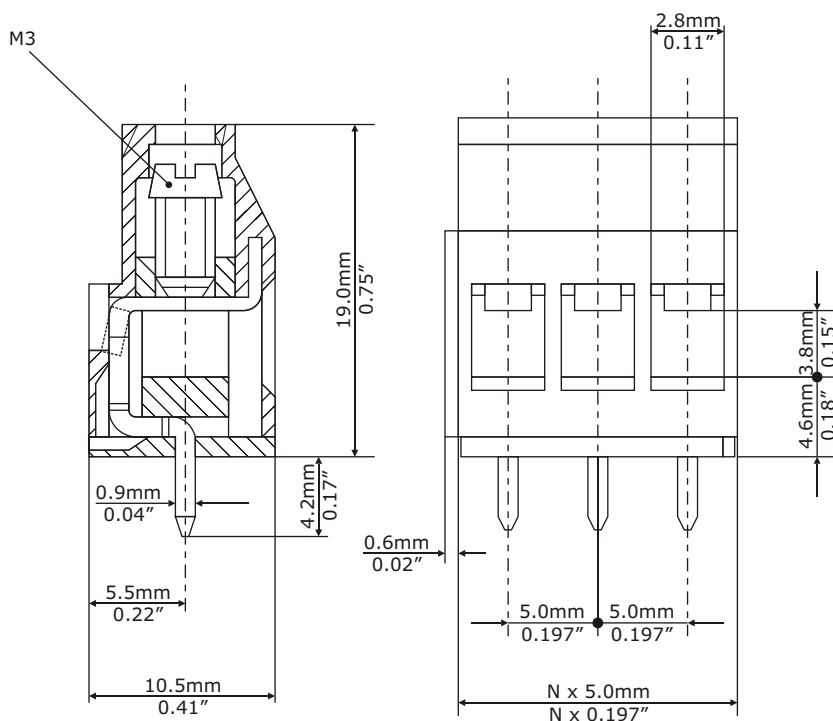

Safety Approval:



### PART NUMBERING

**EB700-XX**

NUMBER OF  
POSITIONS

**RECOMMENDED P.C.B. HOLE SIZE: 1.5mm (0.060")**

N = Number of contacts

**If you require marking or printing on your parts, contact EBY - we can provide blocks to your exact specifications.**

**EBY Electro, Inc.**

210 Express Street  
Plainview, NY 11803-2423 USA

© Copyright 2003 EBY Electro, Inc.



Electro-Mechanical Components Since 1945

[www.ebyelectro.com](http://www.ebyelectro.com)

Email: [info@ebyelectro.com](mailto:info@ebyelectro.com)

Tel: 516.576.7777 · Fax: 516.576.1414