

HORIZONTAL EB705

5mm SPACING, CAGE CLAMP, MINI BLOCK

TECHNICAL DATA

MECHANICAL

Torque:

4.0 lbs-in. Max

Operating temperature:

-33°C to +120°C

-27°F to +248°F

Soldering temperature:

260°C, 500°F for 5 seconds max

MATERIAL

Contact Block:

Brass, Nickel Plated

Contact Solder Pin:

Brass, Tin Plated

Screw:

M3, Steel, Zinc Plated

Insulator body:

Polyamide, UL 94V-0, Blue

ELECTRICAL

Voltage rating:

300VAC

Current rating:

20 Amps

Wire Range:

12-22AWG

DIMENSIONAL REFERENCE

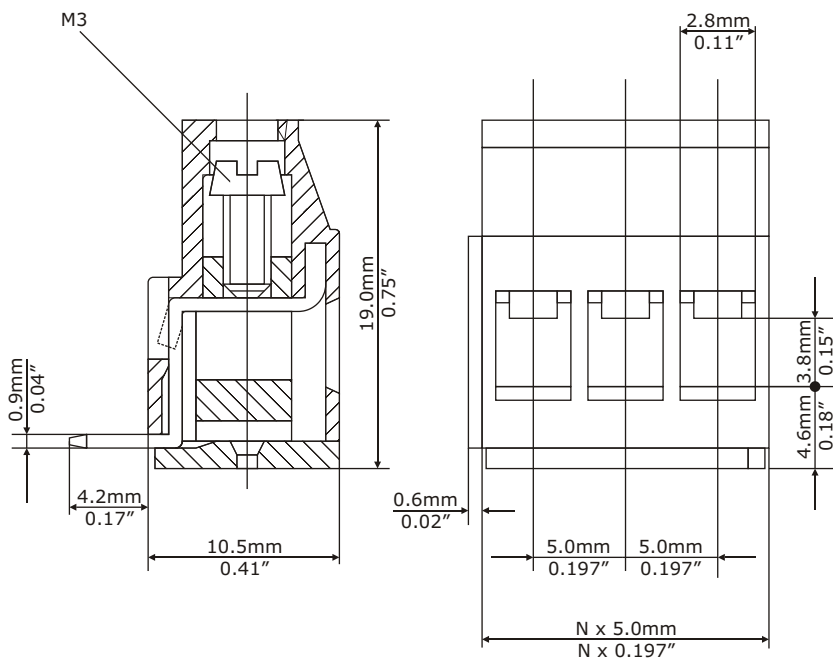

Safety Approval:



PART NUMBERING

EB705-XX

NUMBER OF
POSITIONS

RECOMMENDED P.C.B. HOLE SIZE: 1.5mm (0.060")

N = Number of contacts

If you require marking or printing on your parts, contact EBY - we can provide blocks to your exact specifications.

EBY Electro, Inc.

210 Express Street
Plainview, NY 11803-2423 USA

© Copyright 2003 EBY Electro, Inc.



Electro-Mechanical Components Since 1945

www.ebyelectro.com

Email: info@ebyelectro.com

Tel: 516.576.7777 · Fax: 516.576.1414