

Instrument (1458 Series)

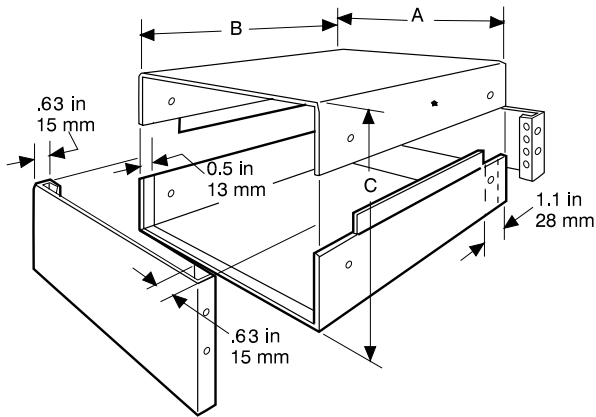

KEY FEATURES

- 20 gauge steel case with black or gulf blue satin finish.
- Easy to machine 0.064" thick aluminum panels front and rear panels (one satin black and one contemporanea grey for each case).
- Symmetrical design so either end panel can be front.
- 6-32 Philips nickel plated screws and self-adhesive rubber feet included.
- Replacement screws **1421J6** (Pkg. of 6, 6-32 Philips head screws).

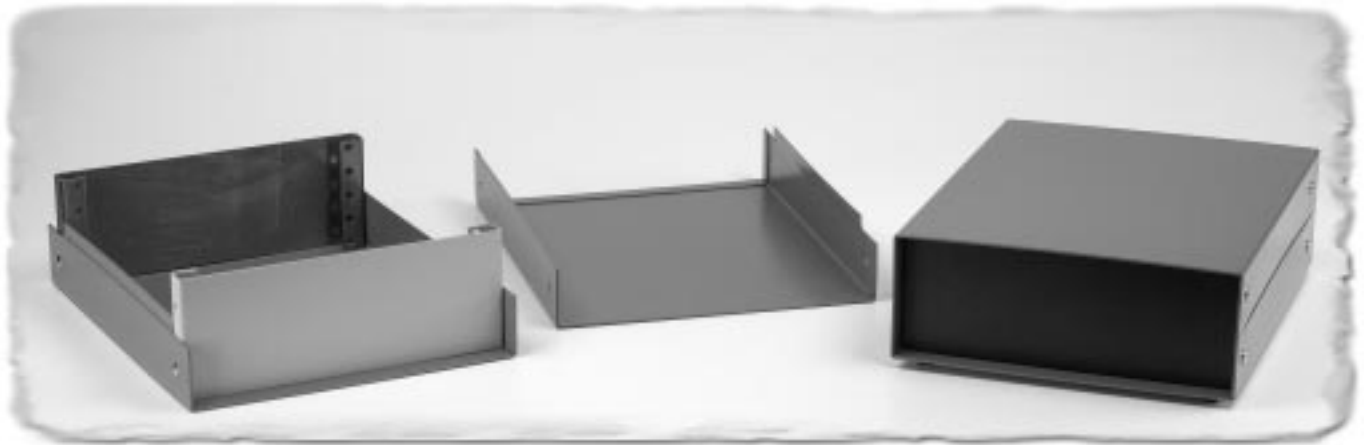
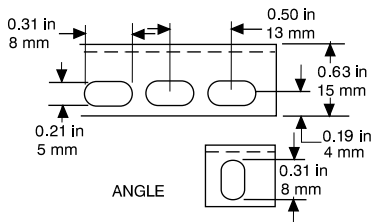

Mounting Rails

- Includes 1 rail, 2 "L" angle brackets, 4 clips and 4 screws per part.

Part Number	Units	Rail length
1448R6	inch mm	5.6 142
1448R8	inch mm	7.6 193
1448R10	inch mm	9.6 244
1448R12	inch mm	11.6 295
1448R14	inch mm	13.6 345
1448A20		Package of 20 angles, clips, & screws

Part Number		Units	Dimensions		
Satin Black	Satin Blue		A	B	C
1458A3	1458A3B	inch mm	4 101	4 101	3 76.2
1458B4	1458B4B	inch mm	6 152	4 101	4 101
1458C3	1458C3B	inch mm	6 152	6 152	3 76.2
1458C4	1458C4B	inch mm	6 152	6 152	4 101
1458D3	1458D3B	inch mm	8 203	8 203	3 76.2
1458D4	1458D4B	inch mm	8 203	8 203	4 101
1458D5	1458D5B	inch mm	8 203	8 203	5 127
1458E3	1458E3B	inch mm	8 203	10 254	3 76.2
1458E4	1458E4B	inch mm	8 203	10 254	4 101
1458E5	1458E5B	inch mm	8 203	10 254	5 127
1458G3	1458G3B	inch mm	10 254	8 203	3 76.2
1458G4	1458G4B	inch mm	10 254	8 203	4 101
1458G5	1458G5B	inch mm	10 254	8 203	5 127

Metal