

# Translucent Polycarbonate (1591 Series)

Plastic



## KEY FEATURES

- Electronic instrument enclosures, designed for mounting printed circuit boards.
- Ideally suited for modern styling or where internal components need to be visible.
- Molded in flame retardant translucent polycarbonate (material carries a UL flammability rating of 94V-0).
- Integral card guides accept 1.5 mm (0.062") P.C. cards.
- Lap joint construction provides protection against access of dust and splashing water.
- Designed to meet IP54
- Molded from translucent, ice blue or infrared translucent red polycarbonate. Visit our web site for color & detail photos of each part.
- Lid is secured with M3 x 10 mm Philips machine screws, threaded into tapped integral brass bushings.

## ACCESSORIES



### P.C. Board Card Adaptors

Allows horizontal mounting of P.C. board(s). **See "Accessories Section" for full details!**

- 1591Z6** - Package of 6
- 1591Z50** - Package of 50
- 1591Z100** - Package of 100



### Flange Kits

Mount to either the rear (using glue) or can be attached to the lid using existing lid screws and holes. **See "Accessories Section" for full details!**



### Replacement Screws

Machine screws, nickel plated, M3 - 0.5 x 10mm

- 1591MS100** - Package of 100



### Belt or Pocket Clip

Molded from tough nylon, includes 2 nylon screws and mounting template.

- 1599CLIP** - Black
- 1599CLIPGY** - Grey

# Translucent Polycarbonate (1591 Series)

Plastic

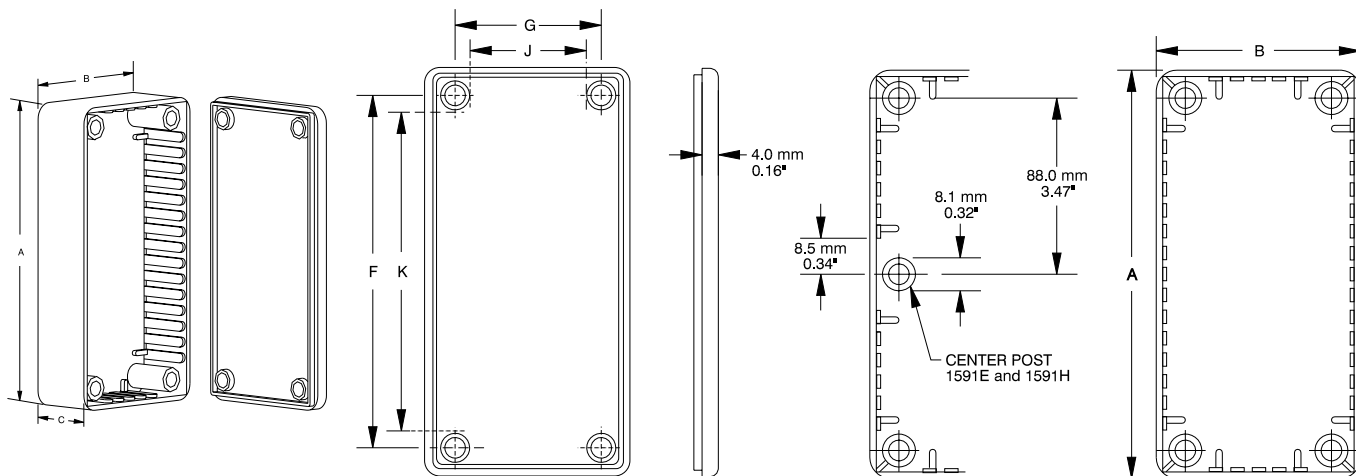

Lid (Inside & Edge View)

Top View

Part Number		Units	Dimensions					P.C. Card Clearance	
Ice Blue	IR Red		A	B	C (No Lid)	F	G	J	K
1591ATBU	1591ATRD	inch mm	3.9 100	2.0 50	0.8 21	3.4 86	1.4 36	1.1 29	3.1 79
1591BTBU	1591BTRD	inch mm	4.4 112	2.4 62	1.1 27	3.9 98	1.9 48	1.6 41	3.5 91
1591CTBU	1591CTRD	inch mm	4.7 120	2.6 65	1.4 36	4.2 106	2.0 51	1.7 44	3.9 99
1591DTBU	1591DTRD	inch mm	5.9 150	3.2 80	1.8 46	5.4 136	2.6 66	2.3 59	5.0 129
1591ETBU	1591ETRD	inch mm	7.5 191	4.3 110	2.2 57	6.9 176	3.8 96	3.5 89	6.6 170

NOTES: - Assembled height = dimension "C" + 0.16" (4.0 mm)  
 - Average wall thickness: 0.06" (1.5 mm)

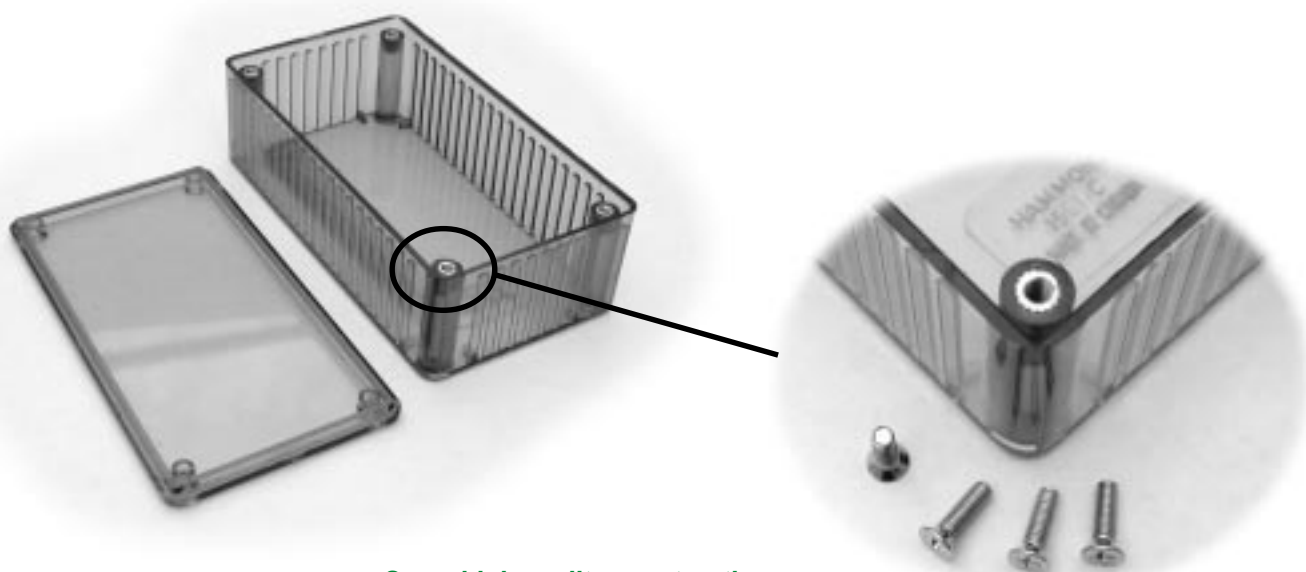

Same high quality construction as our  
 ABS plastic series (brass inserts & machine screws)  
 for repetitive assembly & disassembly...

# General Purpose - ABS (1591 Series)

Plastic

Brass bushings for repetitive assembly and disassembly...

No "gate" marks on bottom...



Uses machine screws into brass bushings...

Lap joint construction...

## OTHER KEY FEATURES

- Electronic instrument enclosures, designed for mounting printed circuit boards.
- Integral card guides accept 1.5 mm (0.062") P.C. cards. 1591E includes a removable center brace.
- Two piece lap joint construction provides protection against access of dust and splashing water.
- Designed to meet IP54
- Molded from flame retardant ABS plastic (material carries a UL flammability rating of 94V-0).
- Lid is secured with M3 x 10 mm Philips machine screws, threaded into integral brass bushings.

## ACCESSORIES



### P.C. Board Card Adaptors

Allows horizontal mounting of P.C. board(s). See "Accessories Section" for full details!  
**1591Z6** - Package of 6  
**1591Z50** - Package of 50  
**1591Z100** - Package of 100



### Replacement Screws

Machine screws, nickel plated, M3 - 0.5 x 10mm  
**1591MS100** - Package of 100



### Flange Kits

Mount to either the rear (using glue) or can be attached to the lid using existing lid screws and holes. See "Accessories Section" for full details!

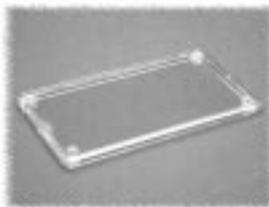

### Clear Lids

Stocked in prototype quantities - made of clear, flame retardant polycarbonate. Lid ONLY.  
**1591LC** - use with 1591L & M  
**1591AC** - use with 1591A  
**1591BC** - use with 1591B  
**1591CC** - use with 1591C  
**1591DC** - use with 1591D  
**1591EC** - use with 1591E  
**1591GC** - use with 1591G  
**1591HC** - use with 1591H  
**1591SC** - use with 1591S  
**1591TC** - use with 1591T  
**1591UC** - use with 1591U  
**1591VC** - use with 1591V



### Belt or Pocket Clip

Molded from tough nylon, includes 2 nylon screws and mounting template.  
**1599CLIP** - Black  
**1599CLIPGY** - Grey

# General Purpose - ABS (1591 Series)

Plastic

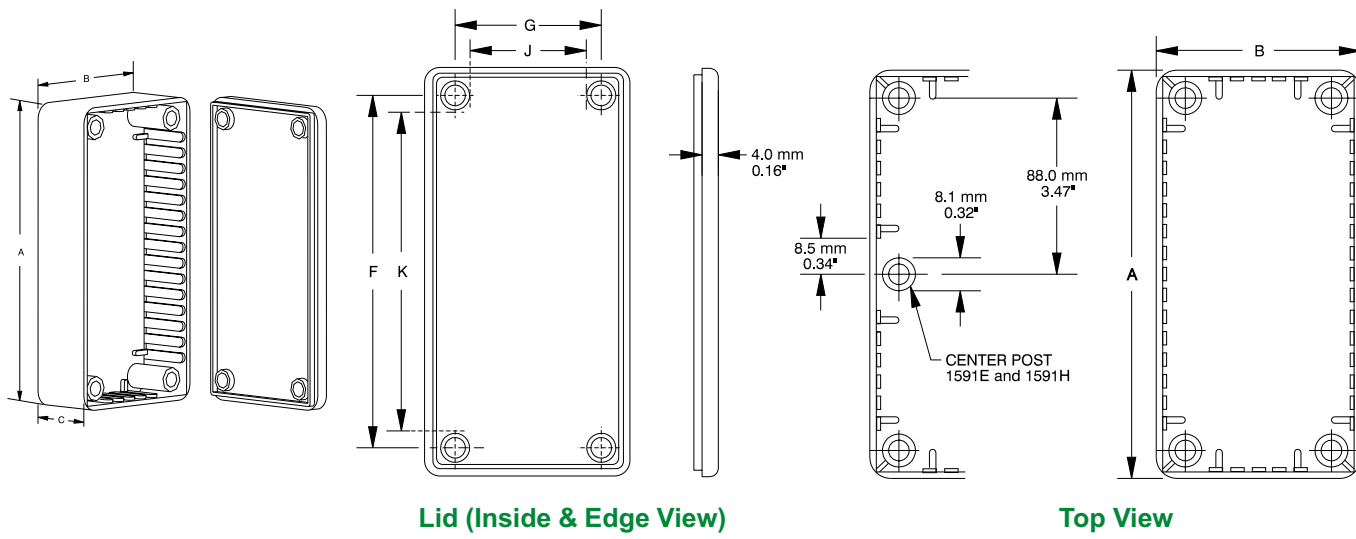

Lid (Inside & Edge View)

Top View

Part Number					Units	Dimensions					P.C. Card Clearance	
Beige	Black	Blue	Grey	Black Shielded		A	B	C (No Lid)	F	G	J	K
1591MBG	1591MBK	1591MBU	1591MGY	1591RMBK	inch	3.3	2.2	0.8	2.8	1.7	1.3	2.5
					mm	85	56	21	71	42	34	63
1591LBG	1591LBK	1591LBU	1591LGY	1591RLBK	inch	3.3	2.2	1.4	2.9	1.7	1.4	2.5
					mm	85	56	35	73	44	35	64
1591ABG	1591ABK	1591ABU	1591AGY	1591RABK	inch	3.9	2.0	0.8	3.4	1.4	1.1	3.1
					mm	100	50	21	86	36	29	79
1591SBG	1591SBK	1591SBU	1591SGY	1591RSBK	inch	4.3	3.2	1.6	3.8	2.7	2.4	3.5
					mm	110	82	40	98	70	61	89
1591BBG	1591BBK	1591BBU	1591BGY	1591RBBK	inch	4.4	2.4	1.1	3.9	1.9	1.6	3.5
					mm	112	62	27	98	48	41	91
1591CBG	1591CBK	1591CBU	1591CGY	1591RCBK	inch	4.7	2.6	1.4	4.2	2.0	1.7	3.9
					mm	120	65	36	106	51	44	99
1591TBG	1591TBK	1591TBU	1591TGY	1591RTBK	inch	4.7	3.2	2.2	4.2	2.6	2.3	3.9
					mm	120	80	55	106	66	59	99
1591UBG	1591UBK	1591UBU	1591UGY	1591RUBK	inch	4.7	4.7	2.2	4.2	4.2	3.9	3.9
					mm	120	120	55	106	106	99	99
1591VBG	1591VBK	1591VBU	1591VGY	1591RVBK	inch	4.7	4.7	3.5	4.2	4.2	3.9	3.9
					mm	120	120	90	106	106	99	99
1591GBG	1591GBK	1591GBU	1591GGY	1591RGBK	inch	4.8	3.7	1.2	4.2	3.1	2.8	3.9
					mm	121	94	30	106	79	73	100
1591DBG	1591DBK	1591DBU	1591DGY	1591RDBK	inch	5.9	3.2	1.8	5.4	2.6	2.3	5.0
					mm	150	80	46	136	66	59	129
1591HBG	1591HBK	1591HBU	1591HGY	1591RHBK	inch	6.5	2.8	1.0	6.0	2.2	1.9	5.6
					mm	165	71	25	153	56	50	144
1591EBG	1591EBK	1591EBU	1591EGY	1591REBK	inch	7.5	4.3	2.2	6.9	3.8	3.5	6.6
					mm	191	110	57	176	96	89	170

NOTES: - Assembled height = dimension "C" + 0.16" (4.0 mm)  
 - Average wall thickness: 0.06" (1.5 mm)

For detailed drawings, CAD files and color photos visit our website at: [www.hammondmg.com](http://www.hammondmg.com)

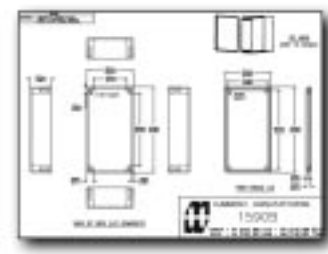
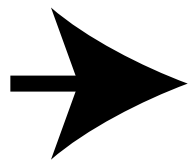

# General Purpose - Polystyrene (1591 Series)

Plastic

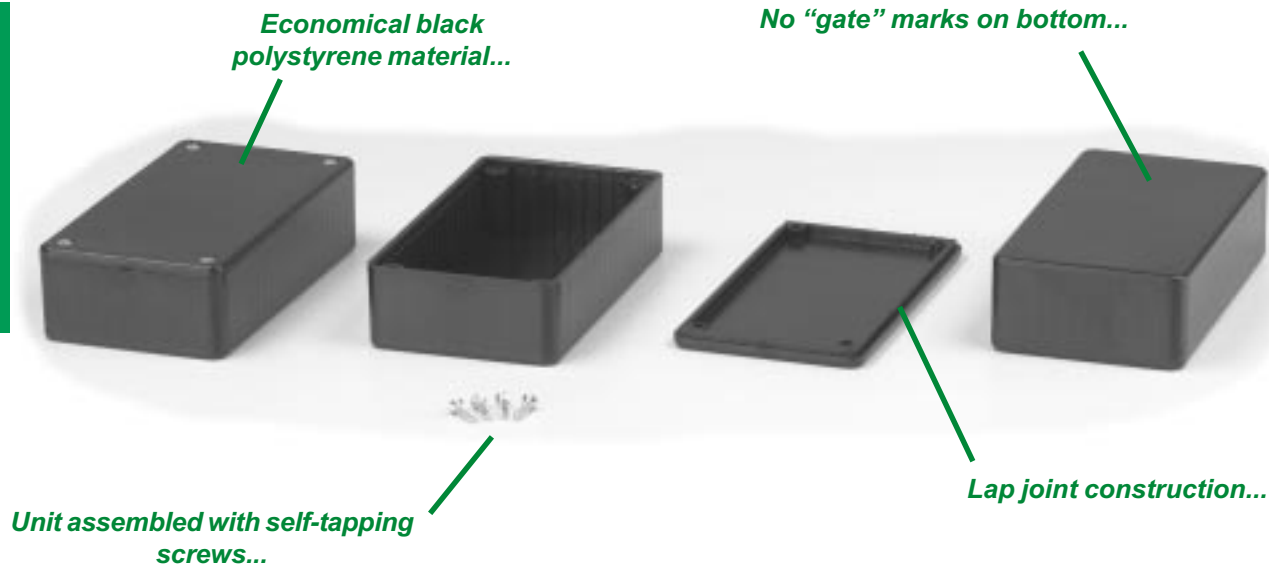

## OTHER KEY FEATURES

- Electronic instrument enclosures, designed for mounting printed circuit boards.
- Integral card guides accept 1.5 mm (0.062") P.C. cards. 1591E includes a removable center brace.
- Lap joint construction provides protection against access of dust and splashing water.
- Designed to meet IP54
- Molded from economical black polystyrene.
- Lid is secured with self-tapping #4 x 0.5" Philips screws.

## ACCESSORIES



### P.C. Board Card Adaptors

Allows horizontal mounting of P.C. board(s). See "Accessories Section" for full details!  
**1591Z6** - Package of 6  
**1591Z50** - Package of 50  
**1591Z100** - Package of 100



### Replacement Screws

Self-tapping type, black anodized, #4 x 0.5"  
**1591TS100BK** - Package of 100



### Flange Kits

Mount to either the rear (using glue) or can be attached to the lid using existing lid screws and holes. See "Accessories Section" for full details!



### Clear Lids

Stocked in prototype quantities - made of clear, flame retardant polycarbonate. Lid ONLY.  
**1591LC** - use with 1591L & M  
**1591AC** - use with 1591A  
**1591BC** - use with 1591B  
**1591CC** - use with 1591C  
**1591DC** - use with 1591D  
**1591EC** - use with 1591E  
**1591GC** - use with 1591G  
**1591HC** - use with 1591H  
**1591SC** - use with 1591S  
**1591TC** - use with 1591T  
**1591UC** - use with 1591U  
**1591VC** - use with 1591V



### Belt or Pocket Clip

Molded from tough nylon, includes 2 nylon screws and mounting template.  
**1599CLIP** - Black  
**1599CLIPGY** - Grey

# General Purpose - Polystyrene (1591 Series)

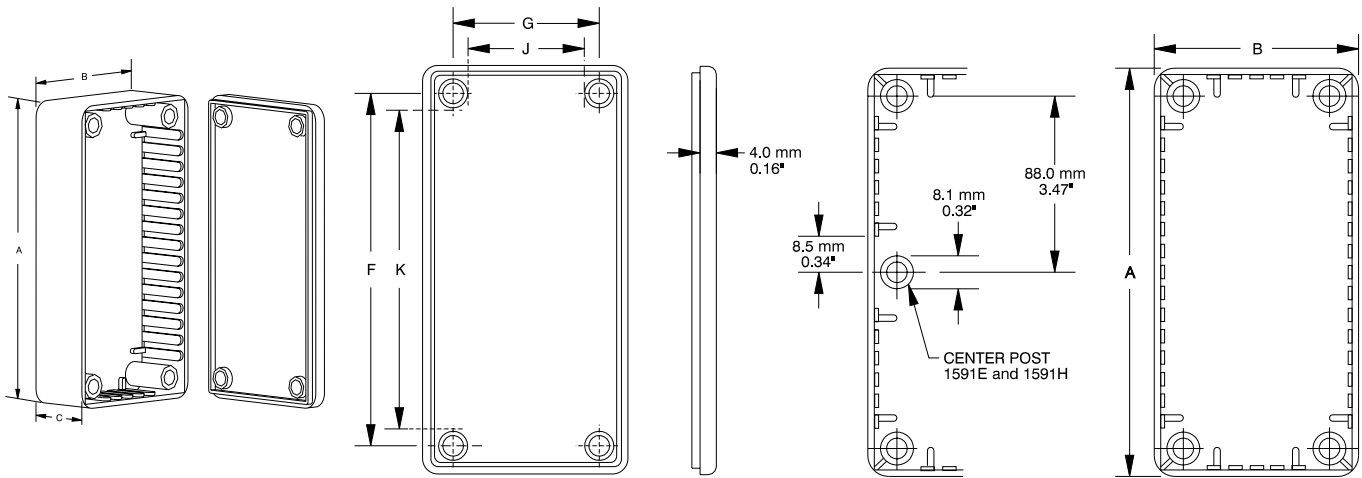

Plastic

Lid (Inside & Edge View)

Top View

Part Number	Units	Dimensions						P.C. Card Clearance	
		A	B	C (No Lid)	F	G	J	K	
1591MSBK	inch	3.3	2.2	0.8	2.8	1.7	1.3	2.5	
	mm	85	56	21	71	42	34	63	
1591LSBK	inch	3.3	2.2	1.4	2.9	1.7	1.4	2.5	
	mm	85	56	35	73	44	35	64	
1591ASBK	inch	3.9	2.0	0.8	3.4	1.4	1.1	3.1	
	mm	100	50	21	86	36	29	79	
1591SSBK	inch	4.3	3.2	1.6	3.8	2.7	2.4	3.5	
	mm	110	82	40	98	70	61	89	
1591BSBK	inch	4.4	2.4	1.1	3.9	1.9	1.6	3.5	
	mm	112	62	27	98	48	41	91	
1591CSBK	inch	4.7	2.6	1.4	4.2	2.0	1.7	3.9	
	mm	120	65	36	106	51	44	99	
1591TSBK	inch	4.7	3.2	2.2	4.2	2.6	2.3	3.9	
	mm	120	80	55	106	66	59	99	
1591USBK	inch	4.7	4.7	2.2	4.2	4.2	3.9	3.9	
	mm	120	120	55	106	106	99	99	
1591VSBK	inch	4.7	4.7	3.5	4.2	4.2	3.9	3.9	
	mm	120	120	90	106	106	99	99	
1591GSBK	inch	4.8	3.7	1.2	4.2	3.1	2.8	3.9	
	mm	121	94	30	106	79	73	100	
1591DSBK	inch	5.9	3.2	1.8	5.4	2.6	2.3	5.0	
	mm	150	80	46	136	66	59	129	
1591HSBK	inch	6.5	2.8	1.0	6.0	2.2	1.9	5.6	
	mm	165	71	25	153	56	50	144	
1591ESBK	inch	7.5	4.3	2.2	6.9	3.8	3.5	6.6	
	mm	191	110	57	176	96	89	170	

NOTES: - Assembled height = dimension "C" + 0.16" (4.0 mm)  
 - Average wall thickness: 0.08" (2.0 mm)

For detailed drawings, CAD files and color photos visit our website at:  
[www.hammondmg.com](http://www.hammondmg.com)

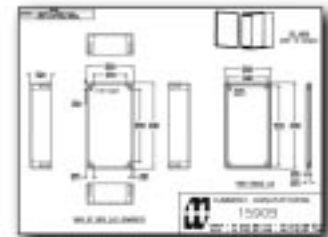
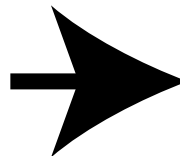

# Flanged Lid Version - ABS (1591 Series)

Plastic



Molded in Flame Retardant ABS

Brass bushings for repetitive assembly and disassembly...

P.C. board standoffs molded into lid...

Lap joint construction...

Enclosure uses machine screws into brass bushings...

## OTHER KEY FEATURES

- Electronic instrument enclosures, designed for mounting printed circuit boards.
- Designed for applications where the enclosure needs to be easily wall or shelf mounted.
- Perfect where extra enclosure security is required by restricting access to lid screws.
- Integral card guides accept 1.5 mm (0.062") P.C. cards. 1591E includes a removable center brace.
- Lap joint construction provides protection against access of dust and splashing water.
- Designed to meet IP54
- Molded from flame retardant ABS plastic (material carries a UL flammability rating of 94V-0).
- Lid is secured with M3 x 10 mm Philips machine screws, threaded into integral brass bushings.

## ACCESSORIES



### P.C. Board Card Adaptors

Allows horizontal mounting of P.C. board(s). See "Accessories Section" for full details!

- 1591Z6** - Package of 6
- 1591Z50** - Package of 50
- 1591Z100** - Package of 100



### Replacement Screws

Machine screws, nickel plated, M3 - 0.5 x 10mm

- 1591MS100** - Package of 100



### P.C. Board Screws

Self-tapping type, used for bosses in the 1591 lid for P.C. board installation. #4 x 1/4" (6.4 mm)

- 1593ATS50** - Package of 50
- 1593ATS100** - Package of 100

# Flanged Lid Version - ABS (1591 Series)

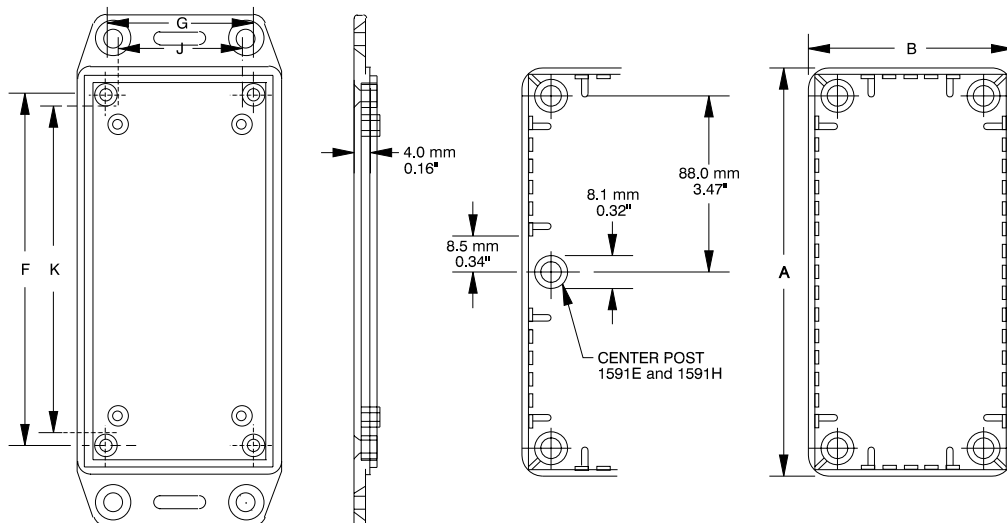

Lid (Inside & Edge View)

Top View

Plastic

Part Number		Units	Dimensions					P.C. Card Clearance	
Black	Grey		A	B	C (No Lid)	F	G	J	K
1591MFLBK	1591MFLGY	inch mm	3.3 85	2.2 56	0.8 21	2.8 71	1.7 42	1.3 34	2.5 63
1591LFLBK	1591LFLGY	inch mm	3.3 85	2.2 56	1.4 35	2.9 73	1.7 44	1.4 35	2.5 64
1591AFLBK	1591AFLGY	inch mm	3.9 100	2.0 50	0.8 21	3.4 86	1.4 36	1.1 29	3.1 79
1591SFLBK	1591SFLGY	inch mm	4.3 110	3.2 82	1.6 40	3.8 98	2.7 70	2.4 61	3.5 89
1591BFLBK	1591BFLGY	inch mm	4.4 112	2.4 62	1.1 27	3.9 98	1.9 48	1.6 41	3.5 91
1591CFLBK	1591CFLGY	inch mm	4.7 120	2.6 65	1.4 36	4.2 106	2.0 51	1.7 44	3.9 99
1591TFLBK	1591TFLGY	inch mm	4.7 120	3.2 80	2.2 55	4.2 106	2.6 66	2.3 59	3.9 99
1591UFLBK	1591UFLGY	inch mm	4.7 120	4.7 120	2.2 55	4.2 106	4.2 106	3.9 99	3.9 99
1591VFLBK	1591VFLGY	inch mm	4.7 120	4.7 120	3.5 90	4.2 106	4.2 106	3.9 99	3.9 99
1591GFLBK	1591GFLGY	inch mm	4.8 121	3.7 94	1.2 30	4.2 106	3.1 79	2.8 73	3.9 100
1591DFLBK	1591DFLGY	inch mm	5.9 150	3.2 80	1.8 46	5.4 136	2.6 66	2.3 59	5.0 129
1591HFLBK	1591HFLGY	inch mm	6.5 165	2.8 71	1.0 25	6.0 153	2.2 56	1.9 50	5.6 144
1591EFLBK	1591EFLGY	inch mm	7.5 191	4.3 110	2.2 57	6.9 176	3.8 96	3.5 89	6.6 170

NOTES: - Assembled height = dimension "C" + 0.16" (4.0 mm)  
 - Average wall thickness: 0.06" (1.5 mm)

For detailed drawings, CAD files and color photos visit our website at: [www.hammondmg.com](http://www.hammondmg.com)

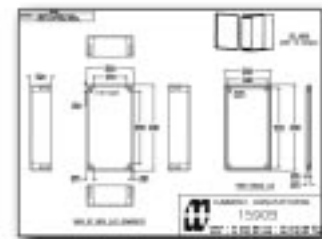
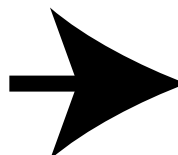



# Flanged Lid Version - Polystyrene (1591 Series)

Plastic

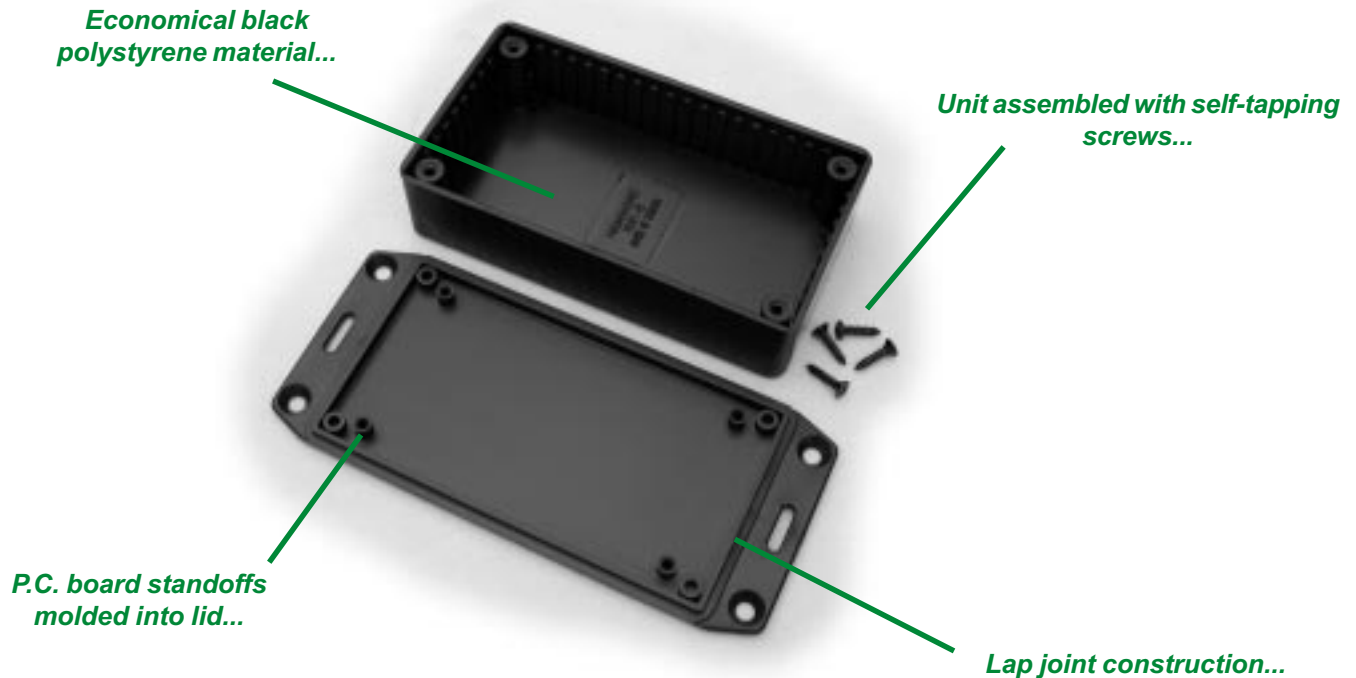

## OTHER KEY FEATURES

- Electronic instrument enclosures, designed for mounting printed circuit boards.
- Integral card guides accept 1.5 mm (0.062") P.C. cards. 1591E includes a removable center brace.
- Two piece lap joint construction provides protection against access of dust and splashing water.
- Designed to meet IP54
- Molded from economical black polystyrene.
- Lid is secured with self-tapping #4 x 0.5" Philips screws.

## ACCESSORIES



### P.C. Board Card Adaptors

Allows horizontal mounting of P.C. board(s). See "Accessories Section" for full details!

- 1591Z6** - Package of 6
- 1591Z50** - Package of 50
- 1591Z100** - Package of 100



### Replacement Screws

Self-tapping type, black anodized, #4 x 0.5"

**1591TS100BK** - Package of 100



### P.C. Board Screws

Self-tapping type, used for bosses in the 1591 lid for P.C. board installation. #4 x 1/4" (6.4 mm)

- 1593ATS50** - Package of 50
- 1593ATS100** - Package of 100

# Flanged Lid Version - Polystyrene (1591 Series)

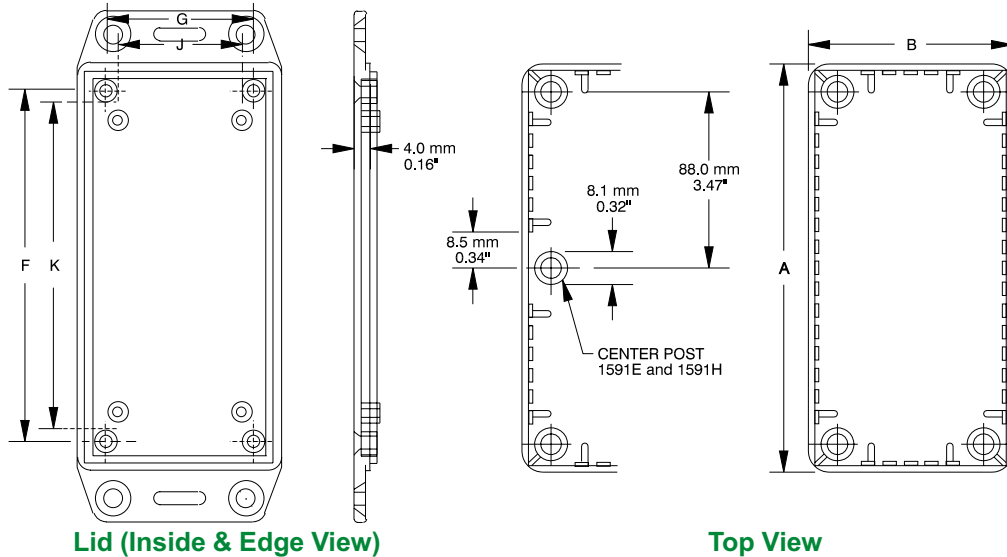

Plastic

Part Number	Units	Dimensions					P.C. Card Clearance	
		A	B	C (No Lid)	F	G	J	K
1591MSFLBK	inch	3.3	2.2	0.8	2.8	1.7	1.3	2.5
	mm	85	56	21	71	42	34	63
1591LSFLBK	inch	3.3	2.2	1.4	2.9	1.7	1.4	2.5
	mm	85	56	35	73	44	35	64
1591ASFLBK	inch	3.9	2.0	0.8	3.4	1.4	1.1	3.1
	mm	100	50	21	86	36	29	79
1591SSFLBK	inch	4.3	3.2	1.6	3.8	2.7	2.4	3.5
	mm	110	82	40	98	70	61	89
1591BSFLBK	inch	4.4	2.4	1.1	3.9	1.9	1.6	3.5
	mm	112	62	27	98	48	41	91
1591CSFLBK	inch	4.7	2.6	1.4	4.2	2.0	1.7	3.9
	mm	120	65	36	106	51	44	99
1591TSFLBK	inch	4.7	3.2	2.2	4.2	2.6	2.3	3.9
	mm	120	80	55	106	66	59	99
1591USFLBK	inch	4.7	4.7	2.2	4.2	4.2	3.9	3.9
	mm	120	120	55	106	106	99	99
1591VSFLBK	inch	4.7	4.7	3.5	4.2	4.2	3.9	3.9
	mm	120	120	90	106	106	99	99
1591GSFLBK	inch	4.8	3.7	1.2	4.2	3.1	2.8	3.9
	mm	121	94	30	106	79	73	100
1591DSFLBK	inch	5.9	3.2	1.8	5.4	2.6	2.3	5.0
	mm	150	80	46	136	66	59	129
1591HSFLBK	inch	6.5	2.8	1.0	6.0	2.2	1.9	5.6
	mm	165	71	25	153	56	50	144
1591ESFLBK	inch	7.5	4.3	2.2	6.9	3.8	3.5	6.6
	mm	191	110	57	176	96	89	170

**NOTES:** - Assembled height = dimension "C" + 0.16" (4.0 mm)  
 - Average wall thickness: 0.08" (2.0 mm)

For detailed drawings, CAD files and color photos visit our website at:  
[www.hammondmg.com](http://www.hammondmg.com)

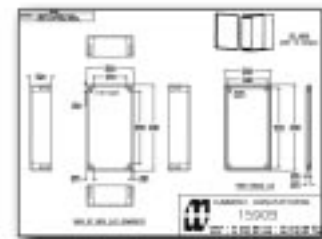
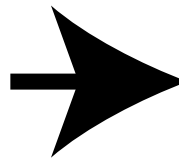

# General Purpose - Flanged (1591 Series)

Plastic

Available in flame retardant ABS plastic OR economical polystyrene (black only)...

Flame retardant ABS version includes wear resistant brass bushings...

Flanges are factory glued to rear (also allows easy access to lid)...

Flange slots allow for easy cable tie hanging...

Flame retardant ABS version includes machine screws (polystyrene are self-tapping)...

## OTHER KEY FEATURES

- Electronic instrument enclosures, designed for mounting printed circuit boards.
- Integral card guides accept 1.5 mm (0.062") P.C. cards. 1591E includes a removable center brace.
- Lap joint construction provides protection against access of dust and splashing water.
- Designed to meet IP54
- Available in either flame retardant black ABS plastic (material carries a UL flammability rating of 94V-0) or economical black polystyrene.
- Flame retardant ABS version's lid is secured with M3 x 10 mm Philips machine screws, threaded into integral brass bushings.
- Polystyrene version's lid is secured with self-tapping #4 x 0.5" Philips screws.

## ACCESSORIES



### P.C. Board Card Adaptors

Allows horizontal mounting of P.C. board(s). See "Accessories Section" for full details!  
**1591Z6** - Package of 6  
**1591Z50** - Package of 50  
**1591Z100** - Package of 100



### Clear Lids

Stocked in prototype quantities - made of clear flame retardant polycarbonate. Lid ONLY.

**1591LC** - use with 1591L & M  
**1591AC** - use with 1591A  
**1591BC** - use with 1591B  
**1591CC** - use with 1591C  
**1591DC** - use with 1591D  
**1591EC** - use with 1591E  
**1591GC** - use with 1591G  
**1591HC** - use with 1591H  
**1591SC** - use with 1591S  
**1591TC** - use with 1591T  
**1591UC** - use with 1591U  
**1591VC** - use with 1591V



### Replacement Screws

Machine screws, nickel plated, M3 - 0.5 x 10mm (used in the ABS version).  
**1591MS100** - Package of 100



### Replacement Screws

Self-tapping type, black anodized, #4 x 0.5" (used in the polystyrene version).  
**1591TS100BK** - Package of 100

# General Purpose - Flanged (1591 Series)

Plastic

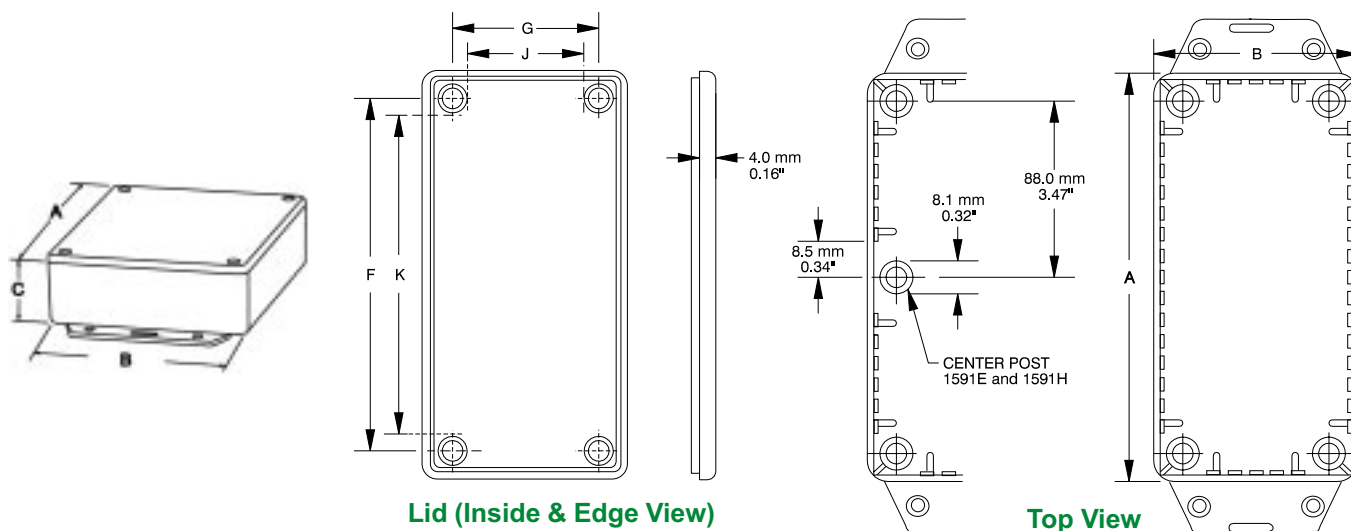

Lid (Inside & Edge View)

Top View

Part Number		Units	Dimensions					P.C. Card Clearance	
Black ABS with flange	Black Styrene with flange		A	B	C (No Lid)	F	G	J	K
1591MFBK	1591MFSBK	inch mm	3.3 85	2.2 56	0.8 21	2.8 71	1.7 42	1.3 34	2.5 63
1591LFBK	1591LFSBK	inch mm	3.3 85	2.2 56	1.4 35	2.9 73	1.7 44	1.4 35	2.5 64
1591AFBK	1591AFSBK	inch mm	3.9 100	2.0 50	0.8 21	3.4 86	1.4 36	1.1 29	3.1 79
1591SFBK	1591SFSBK	inch mm	4.3 110	3.2 82	1.6 40	3.8 98	2.7 70	2.4 61	3.5 89
1591BFBK	1591BFSBK	inch mm	4.4 112	2.4 62	1.1 27	3.9 98	1.9 48	1.6 41	3.5 91
1591CFBK	1591CFSBK	inch mm	4.7 120	2.6 65	1.4 36	4.2 106	2.0 51	1.7 44	3.9 99
1591TFBK	1591TFSBK	inch mm	4.7 120	3.2 80	2.2 55	4.2 106	2.6 66	2.3 59	3.9 99
1591UFBK	1591UFSBK	inch mm	4.7 120	4.7 120	2.2 55	4.2 106	4.2 106	3.9 99	3.9 99
1591VFBK	1591VFSBK	inch mm	4.7 120	4.7 120	3.5 90	4.2 106	4.2 106	3.9 99	3.9 99
1591GFBK	1591GFSBK	inch mm	4.8 121	3.7 94	1.2 30	4.2 106	3.1 79	2.8 73	3.9 100
1591DFBK	1591DFSBK	inch mm	5.9 150	3.2 80	1.8 46	5.4 136	2.6 66	2.3 59	5.0 129
1591HFBK	1591HFSBK	inch mm	6.5 165	2.8 71	1.0 25	6.0 153	2.2 56	1.9 50	5.6 144
1591EFBK	1591EFSBK	inch mm	7.5 191	4.3 110	2.2 57	6.9 176	3.8 96	3.5 89	6.6 170

NOTES: - Assembled height = dimension "C" + 0.16" (4.0 mm)  
 - Average wall thickness: Flame retardant ABS=0.06" (1.5 mm), Polystyrene = 0.08" (2.0 mm)

For detailed drawings, CAD files or color photos visit our website at:

[www.hammondmfg.com](http://www.hammondmfg.com)

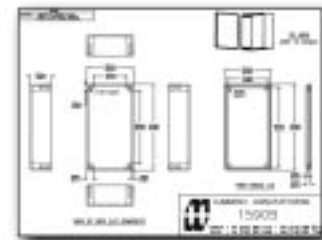
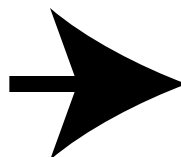

Hammond Manufacturing Co. Ltd.  
 394 Edinburgh Rd. North  
 Guelph, Ontario N1H 1E5 CANADA  
 © Phone: 519-822-2960 Fax: 519-822-0715



Hammond Manufacturing Co. Inc.  
 256 Sonwil Dr.  
 Cheektowaga, NY 14225 USA  
 Phone: 716-651-0086 Fax: 716-651-0726