



1427C1

- 4" (102mm) hole to hole mounting centers
- 4.4" (111mm) length
- 1.3" (33mm) height
- 3/8" (9.5mm) diameter round bright nickel finished brass
- 10-32 hardware included
- thread depth is 9/16" (14.3mm)



1427C6

- 2.7" (70mm) hole to hole mounting centers
- 3.5" (89mm) length
- 1.5" (38mm) height
- clear anodized satin finish aluminum
- 8-32 hardware included
- thread depth is 7/16" (11.11mm)



1427C2

- 4" (102mm) hole to hole mounting centers
- 4.4" (111mm) length
- 1.3" (33mm) height
- 5/8" x 9/32" (15.9 x 7.14mm) oval, satin nickel finished brass
- 10-32 hardware included
- thread depth is 1/2" (12.7mm)



1427L

- 7" (178mm) hole to hole mounting centers
- 7.4" (187mm) length
- 1.2" (30mm) height
- chrome plated steel
- 10-32 hardware included
- .375" (10mm) diameter



1427C4

- 4.4" (111mm) hole to hole mounting centers
- 5" (127mm) length
- 1" (25mm) height
- black anodized satin finish aluminum
- 8-32 hardware included
- thread depth is 3/8" (9.5mm)



1427M

- 5.3" (133mm) hole to hole mounting centers
- 5.6" (141mm) length
- 1.2" (30mm) height
- chrome plated steel
- 10-32 hardware included
- .375" (10mm) diameter



1427C5

- 4" (102mm) hole to hole mounting centers
- 4.2" (108mm) length
- 1.3" (34mm) height
- 1/4" x 7/8" (6.35 x 22.2mm) rectangular, clear anodized brushed finish aluminum
- 8-32 hardware included
- thread depth is 7/16" (11.11mm)



1427N

- 3.5" (89mm) hole to hole mounting centers
- 3.9" (99mm) length
- 1.2" (30mm) height
- chrome plated steel
- 10-32 hardware included
- .375" (10mm) diameter



Handles



1427P

- 2.8" (71mm) hole to hole mounting centers
- 3" (76mm) length
- .95" (24mm) height
- chrome plated steel
- 6-32 hardware included
- .25" (6mm) diameter



M250-1003

- 4" (102mm) hole to hole mounting centers
- 4.4" (111mm) length
- 1.4" (36mm) height
- black nylon carry handle
- 55 lb. load capacity
- hardware included
- .52" (13mm) diameter



1427Q

- 2.3" (58mm) hole to hole mounting centers
- 2.5" (64mm) length
- .95" (24mm) height
- chrome plated steel
- 6-32 hardware included
- .25" (6mm) diameter



M250-1393

- 5.6" (141mm) hole to hole mounting centers
- 6.1" (154mm) length
- 1.7" (42mm) height
- black nylon carry handle
- 132 lb. load capacity
- hardware included
- .79" (20mm) diameter



M286-6

- 3.9" (99mm) hole to hole mounting centers
- 4.6" (118mm) length
- 1.7" (42mm) height
- spring-locked, chrome plated steel folding handle
- carry capacity of 220 lbs. (100kg) per pair
- hardware included
- sold in pairs



M268-2

- 3.5" (88mm) hole to hole mounting centers
- 4" (102mm) length
- 1.6" (40mm) height
- matte anodized aluminum handle
- hardware included
- .48" (12mm) diameter



M250-663

- 2.7" (67mm) hole to hole mounting centers
- 3" (75mm) length
- 1.3" (32mm) height
- black nylon carry handles
- hardware included



M268-3

- 4.8" (121mm) hole to hole mounting centers
- 5.3" (134mm) length
- 1.6" (40mm) height
- matte anodized aluminum handle
- hardware included
- .48" (12mm) diameter



M268-4

- 7.1" (181mm) hole to hole mounting centers
- 7.6" (194mm) length
- 1.6" (40mm) height
- matte anodized aluminum handle
- hardware included
- .48" (12mm) diameter



M3299-1231

- 3" (75mm) hole to hole mounting centers
- 3.4" (87mm) length
- 1.6" (40mm) height
- matte anodized aluminum handle
- hardware included
- .30" (8mm) diameter



M268-5

- 9.3" (237mm) hole to hole mounting centers
- 9.8" (249mm) length
- 1.6" (40mm) height
- matte anodized aluminum handle
- hardware included
- .48" (12mm) diameter



M3299-1301

- 4.7" (119mm) hole to hole mounting centers
- 5.2" (131mm) length
- 1.6" (40mm) height
- matte anodized aluminum handle
- hardware included
- .30" (8mm) diameter



1427F

- 3.7" (94mm) hole to hole mounting centers
- 4.9" (124mm) length
- 2.2" (56mm) height
- black, scratch resistant, light weight polystyrene handle
- 60 lb. load capacity
- nickel plated steel support posts
- hardware included
- .43" (11mm) diameter



1427J

- 8.5" (216mm) long
- .77" (20mm) width
- .19" (5mm) height
- 7.25" (184mm) mounting centers
- chrome caps on a fluted soft vinyl strap with a spring steel core
- 50 lb. load capacity
- hardware included



M3299-1131

- 1.3" (32mm) hole to hole mounting centers
- 1.7" (42mm) length
- 1.6" (40mm) height
- matte anodized aluminum handle
- hardware included
- .30" (8mm) diameter



1427K

- 5" (128mm) length
- 3.5" (90mm) height
- .68" (17mm) depth
- black plastic tray with grey plastic folding handle
- handle is 4.1" (104mm) wide and 2.5" (63mm) high
- steady load capacity of 75 lbs. per handle
- simple installation: secured by 2 clips (included)



Handles, Feet & Cable Wraps



M262-01

- 5.9" (150mm) length
- 4.1" (105mm) height
- .65" (17mm) depth
- galvanized steel, flush mount screw down tray
- polished aluminum handle
- handle is 4.7" (120mm) wide and 3" (77mm) high
- steady load capacity of 330 lbs. per pair
- hardware included
- sold in pairs



M3784-7001

- 2.6" (67mm) length (in closed position)
- 1.8" (46mm) height (in open position)
- black polyamide spring locked folding legs
- hardware included
- sold in pairs



M263-1

- 5.1" (130mm) length
- 3.6" (91mm) height
- .79" (20mm) depth
- black steel tray
- folding, spring loaded polished steel handle
- handle is 4" (102mm) wide and 2.3" (59mm) high
- steady load capacity of 275 lbs. per pair
- hardware not included
- sold in pairs

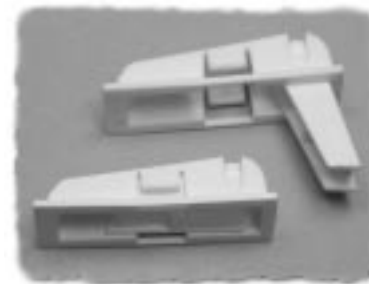

1427X

- 2.5" (63mm) length (in closed position)
- 1.35" (34mm) height (in open position)
- white ABS plastic folding legs
- sold in pairs



M3255-2001

- 7.6" (194mm) length
- 3" (76mm) height
- .83" (21mm) depth
- silver steel tray
- folding black matte handle
- handle is 6.4" (164mm) wide and 2.3" (59mm) high
- carry capacity of 220 lbs. per pair
- hardware not included
- sold in pairs

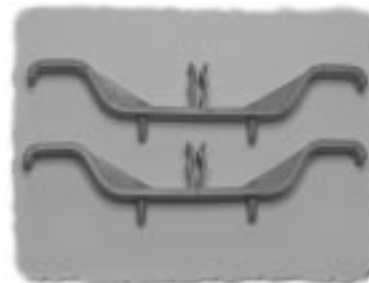

M795

- 4.8" (122mm) overall length
- grey plastic cord wrap
- simple installation: secured by two clips each (included)
- sold in pairs



M797-24

- 1.1" (27mm) length
- .64" (16mm) height
- .55" (14mm) depth
- black polyamide fixed rear legs
- hardware included
- sold in pairs



M795-2

- 5" (126mm) overall length
- zinc plated cord wrap
- mounting hardware not included
- sold in pairs

RUBBER FEET



1421T2



1421T3



1421T4



1421T5CL



1421T6CL



1421T7



1421T8BK



1421T9BK

Rubber Feet						
Part Number	Description	Color	Dimensions		Style	Pkg. Qty
1421T2	Self-adhesive	Black	.5" x .14"	12.7 x 3.5 mm	Flat Round	24
1421T2CL	Self-adhesive	Clear	.5" x .14"	12.7 x 3.5 mm	Flat Round	24
1421T2GY	Self-adhesive	Grey	.5" x .14"	12.7 x 3.5 mm	Flat Round	24
1421T3	Self-adhesive	Black	.5" x .23"	12.7 x 5.8 mm	Square	24
1421T4	Self-adhesive	Black	.81" x .30"	20.5 x 7.6 mm	Square	24
1421T5BK	Self-adhesive	Black	.44" x .20"	11.1 x 5 mm	Hemisphere	24
1421T5CL	Self-adhesive	Clear	.44" x .20"	11.1 x 5 mm	Hemisphere	24
1421T6CL	Self-adhesive	Clear	.31" x .09"	7.9 x 2.2 mm	Flat Round	24
1421T7	Screw-on	Black	.75" x .5"	19 x 12.7 mm	Round	24
1421T8BK	Self-adhesive	Black	.47" x .12"	12.1 x 3.1 mm	Square	24
1421T9BK	Self-adhesive	Black	.88" x .40"	22.35 x 10.16 mm	Round	24

BAILS

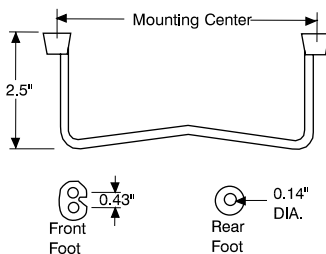

Bails - (Tilt Stand)		
Part Number	Mounting Centers	
	inches	mm
1427D5	5.5	139.7
1427D7	7.0	177.8
1427D10	10.0	254.0



HARDWARE

Part Number	Qty. per pkg.	Hardware Accessories
BH1AAWKIT	1	Battery holder kit for 1 AA cell for 1599 B & E series
BH2AAWKIT	1	Battery holder kit for 2 AA cell for 1599 B & E series
BH1AAAWKIT	1	Battery holder kit for 1 AAA cell for 1599 B & E series
BH2AAAWKIT	1	Battery holder kit for 2 AAA cell for 1599 B & E series
BH3AAAWKIT	1	Battery holder kit for 3 AAA cell for 1599E series
BH4AAAWKIT	1	Battery holder kit for 4 AAA cell for 1599E series
BS61KIT	1	Battery holder kit for 1 - 9V cell for 1599 B & E series
1427KR	1	Key ring kit for 1551 series
1448A20	20	Angles, clips and screws for 1448 rails
1448R6	1	Mounting rails for 1401 & 1458 series (5.6" - 142mm)
1448R8	1	Mounting rails for 1401 & 1458 series (7.6" - 193mm)
1448R10	1	Mounting rails for 1401 & 1458 series (9.6" - 244mm)
1448R12	1	Mounting rails for 1401 & 1458 series (11.6" - 295mm)
1448R14	1	Mounting rails for 1401 & 1458 series 13.6" - 345mm)
1591AC	1	Clear plastic lid for 1591A series
1591BC	1	Clear plastic lid for 1591B series
1591CC	1	Clear plastic lid for 1591C series
1591DC	1	Clear plastic lid for 1591D series
1591EC	1	Clear plastic lid for 1591E series
1591GC	1	Clear plastic lid for 1591G series
1591HC	1	Clear plastic lid for 1591H series
1591LC	1	Clear plastic lid for 1591L series
1591SC	1	Clear plastic lid for 1591S series
1591TC	1	Clear plastic lid for 1591T series
1591UC	1	Clear plastic lid for 1591U series
1591VC	1	Clear plastic lid for 1591V series
1591Z6	6	P.C. card adaptors for 1590 (L-R) & 1591 series
1591Z50	50	P.C. card adaptors for 1590 (L-R) & 1591 series
1591Z100	100	P.C. card adaptors for 1590 (L-R) & 1591 series
1592ETG	1	Gasket kit for 1592 "T" case
1592ETM	1	Magnetic 3" pad for rear of 1592 "T" case
1592ETRF	6	Rubber feet for 1592 "T" case
1592ETV	1	Velcro mounting pad for 1592 "T" case
1593DIR10	10	Infrared panels for 1593D
1593PIR10	10	Infrared panels for 1593J, K, P, Q, Y & X
1593SIR10	10	Infrared panels for 1593S & T
1594AZ25	25 sets	P.C. card guides for 1594A series
1594AD5	5 sets	P.C. card guides for 1594A series
1594BZ25	25 sets	P.C. card guides for 1594B series
1594BD5	5 sets	P.C. card guides for 1594B series
1594CZ25	25 sets	P.C. card guides for 1594C series
1594CD5	5 sets	P.C. card guides for 1594C series
1594DZ25	25 sets	P.C. card guides for 1594D series
1594DD5	5 sets	P.C. card guides for 1594D series
1594EZ25	25 sets	P.C. card guides for 1594E series
1594ED5	5 sets	P.C. card guides for 1594E series

HARDWARE

Part Number	Qty. per pkg.	Hardware Accessories
1598PLABK	2	Black plastic end panels for 1598A series
1598PLBBK	2	Black plastic end panels for 1598B series
1598PLBBBK	2	Black plastic end panels for 1598BB series
1598PLCBK	2	Black plastic end panels for 1598C series
1598PLDBK	2	Black plastic end panels for 1598D series
1598PLEBK	2	Black plastic end panels for 1598E series
1598PLFBK	2	Black plastic end panels for 1598F series
1598PLGBK	2	Black plastic end panels for 1598G series
1598PLHBK	2	Black plastic end panels for 1598H series
1598PLJBK	2	Black plastic end panels for 1598J series
1599BD5	5	Plastic battery dividers for 1599B series
1599BD100	100	Plastic battery dividers for 1599B series
1599CLIP	1	Black nylon belt or pocket clip with hardware
1599CLIPGY	1	Grey nylon belt or pocket clip with hardware
1599ED5	5	Plastic battery dividers for 1599E series
1599ED100	100	Plastic battery dividers for 1599E series
1599HD5	5	Plastic battery dividers for 1599H series
1599HD100	100	Plastic battery dividers for 1599H series

SCREWS

Part Number	Qty per pkg.	Replacement & Accessory Screws	Screw Size
1421J6	6	Self tapping for most metal case series	6-32 philips, nickel plated
1551ATS100	100	Self tapping type for 1551 series	#2 x 3/16" nickel plated
1590MS100	100	Machine type for 1590 (except L, M & R) series	6-32 x 1/2" nickel plated
1590MS50BK	50	Black machine type for 1590 series	6-32 x 1/2"
1590MS50BU	50	Blue machine type for 1590 series	6-32 x 1/2"
1590MS50GY	50	Grey machine type for 1590 series	6-32 x 1/2"
1591MS100	100	Machine type for 1591 & 1598 series	M3 - 0.5 x 10mm
1591TS100	100	Self tapping type for 1591 styrene and 1551 series	#4 x 0.5" nickel plated
1591TS100BK	100	Black self tapping type for 1591 styrene and 1551 series	#4 x 0.5"
1593ATS50	50	Self tapping pan head for 1593, 1591 flange lid & 1599 series	#4 x 1/4" (6.4mm)
1593ATS100	100	Self tapping pan head for 1593, 1591 flange lid & 1599 series	#4 x 1/4" (6.4mm)
1593MS100	100	Self tapping, oval head for 1593 series	#4 x 0.625" (15.9mm)
1594MS100	100	Machine type for 1594, 1599B, and 1592 series	M3 - 0.5 x 18mm
1594TS100	100	Self tapping for 1594 & 1599ES styrene series	#4 x 25.4mm (1")
1594WMS100	100	Machine type for 1594 watertight series & 1599E	M3 - 0.5 x 25mm
1595MS100	100	Machine type for 1595 series	M3 - 0.5 x 8mm
1598ATS100	100	Screws for stand-off bosses in 1595 & 1598	#6 x 1/4" (6.4mm)
1598TS100	100	Self tapping for 1598 styrene series	#4 x 5/8"
1599BTS100	100	Self tapping for 1599BS styrene series	#4 x 3/4"
1599HMS100	100	Machine type for 1599H series	M3 - 0.5 x 28mm
1599HTS100	100	Self tapping for 1599HS styrene series	#4 x 1 5/16"



Flange Kits & P.C. Board Adaptors

PLASTIC FLANGE KITS

Flange kits mount to the rear of our 1591 series (using glue)...

Three sizes cover our entire 1591 series...

Flange kits can be screwed to the lid of our 1591 series...

Flange slots allow for easy cable tie hanging...

Box Mount

Used with Enclosure	Box mounted flange Part Number
1591L	1591F1BK-10
1591A	1591F1BK-10
1591B	1591F1BK-10
1591C	1591F1BK-10
1591D	1591F2BK-10
1591E	1591F3BK-10
1591G	1591F2BK-10
1591H	1591F1BK-10
1591M	1591F1BK-10
1591S	1591F2BK-10
1591T	1591F2BK-10
1591U	1591F3BK-10
1591V	1591F3BK-10

SOLD IN PACKS OF 10

Molded in the same high quality, high strength, fire retardant ABS plastic (black only) as our 1591 series.

NOTE: When gluing flanges to ABS plastic boxes we recommend standard ABS cement. To glue flanges to our styrene enclosures we recommend a faster setting glue like Loctite's "Quick Tite"

Lid Mount

Used with Enclosure	Lid mounted flange Part Number
1591L	1591F1BK-10
1591A	1591F1BK-10
1591B	1591F1BK-10
1591C	1591F2BK-10
1591D	1591F2BK-10
1591E	1591F3BK-10
1591G	1591F3BK-10
1591H	1591F2BK-10
1591M	1591F1BK-10
1591S	1591F3BK-10
1591T	1591F2BK-10
1591U	1591F3BK-10
1591V	1591F3BK-10

SOLD IN PACKS OF 10

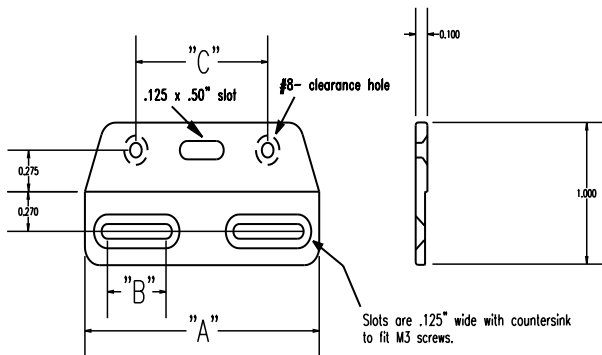

Part Number	Units	Dimensions		
		A	B	C
1591F1BK-10	inch mm	2.2 56	.25 6.4	1.5 38
1591F2BK-10	inch mm	3.0 76	.26 6.6	2.0 51
1591F3BK-10	inch mm	4.5 114	.60 15	3.25 83

P. C. CARD ADAPTORS

P.C. Board Card Adaptors

Allows horizontal mounting of P.C. board(s). **For the 1591 and ribbed 1590 series only.**

- 1591Z6 - Package of 6
- 1591Z50 - Package of 50
- 1591Z100 - Package of 100

