



P.O. Box 2956 · Syracuse · New York · 13220  
 Phone: (315) 433-1150 Fax: (315) 433-1521  
 Toll Free US & Canada: (800) 334-0837  
 Email: sales@infitec.com

# S SERIES OPEN BOARD TIME DELAY RELAYS

## FEATURES

- C/MOS Digital Circuitry
- Time Delays to 1000 Minutes
- No First Cycle Effect
- 0.5% Repeat Accuracy
- 2% Stability Over Voltage and Temperature
- Wide Voltage Selection 24-230 VAC, 12-110 VDC
- Low Cost, Open Board Construction
- DPDT 10 Ampere Output Rating
- UL/cUL Recognized

## SPECIFICATIONS

### 1. Time Delay

- 1.1 Type: C/MOS Digital Circuitry
- 1.2 Range: From 0.05 Seconds to 1000 Minutes  
Fixed Delays Available (See Time Delay Range Chart)
- 1.3 Repeat Accuracy:  $\pm 0.5\%$  Under Fixed Conditions
- 1.4 Setting Accuracy:  $\pm 10\%$
- 1.5 Reset Time: 100 Milliseconds Maximum
- 1.6 Recycle Time: 150 Milliseconds
- 1.7 Time Delay vs. Voltage and Temperature:  $\pm 2\%$

### 2. Input

- 2.1 Operating Voltage: 24, 120, & 230 VAC, 12, 24, & 110 VDC
- 2.2 Tolerance:  $\pm 20\%$  of Nominal
- 2.3 Frequency: 50 - 60 Hertz

### 3. Output

- 3.1 Type: Electromechanical Relay
- 3.2 Form: DPDT
- 3.3 Rating: 10 Amperes Resistive at 120 VAC
- 3.4 Life: Electrical - Full Load - 1,000,000 Operations  
Mechanical - 10,000,000 Operations

### 4. Protection

- 4.1 Transient:  $\pm 1500$  Volts for 150 Microseconds
- 4.2 Polarity: DC Units are Reverse Polarity Protected
- 4.3 Dielectric Breakdown: 1500 Volts RMS Minimum

### 5. Mechanical

- 5.1 Mounting: #6 Screw Clearance (4 Places)
- 5.2 Termination: 3/16" or 1/4" Quick Connect Terminals
- 5.3 Style: Open Board/Surface Mount

### 6. Environmental

- 6.1 Operating Temperature:  $-20^{\circ}\text{C}$  to  $+80^{\circ}\text{C}$
- 6.2 Storage Temperature:  $-30^{\circ}\text{C}$  to  $+85^{\circ}\text{C}$
- 6.3 Humidity: 95% Relative Non-Condensing

## MODE OF OPERATION

### DELAY ON MAKE

Upon application of power to the input terminals, the time delay begins. At the completion of the pre-selected time delay, the output contacts transfer. Reset is accomplished by removal of input power. There is no false output when reset during timing.

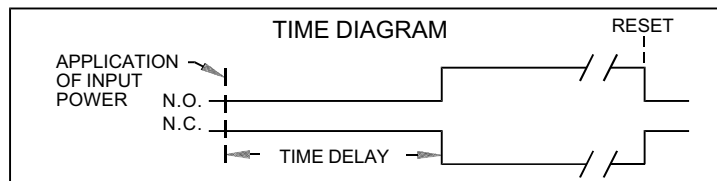

## SERIES

### SMR

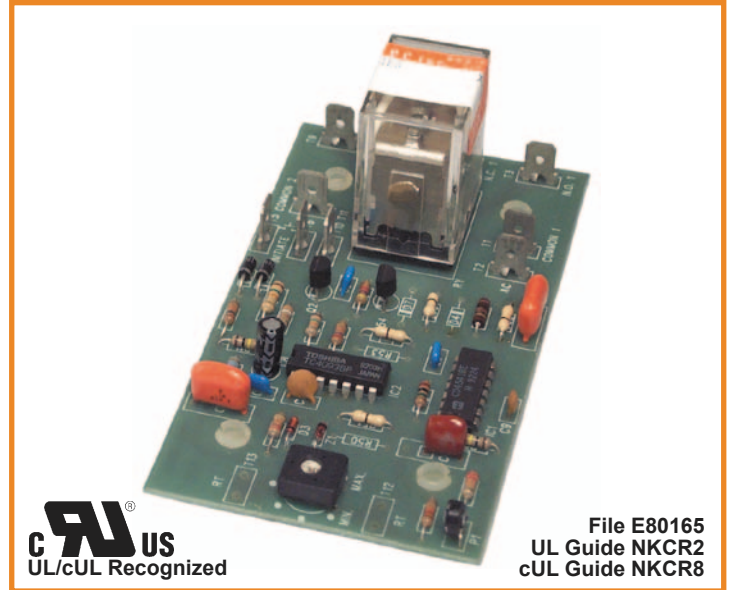

**UL**  
UL/cUL Recognized

File E80165  
UL Guide NKCR2  
cUL Guide NKCR8

## INTERVAL

## SIR

Upon application of power to the input terminals, the output contacts immediately transfer and the time delay begins. At the completion of the pre-selected time delay, the output contacts revert to their original position. Reset is accomplished by removal of input power.

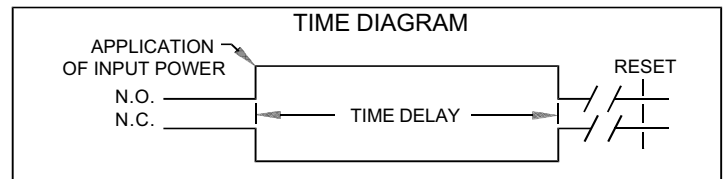

## SINGLE SHOT

## SSR

Power must be applied to the input at all times prior to and during timing. Upon closure of the initiate switch (momentary or maintained) the output contacts transfer and the time delay begins. At the completion of the pre-selected delay period, the output contacts revert to their original position. Removal of input power will reset the control.

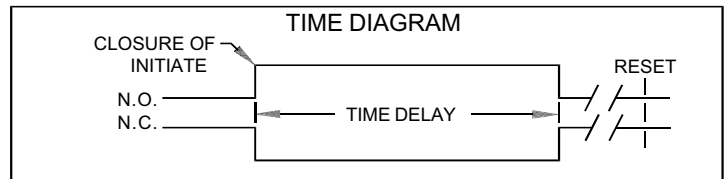

## DELAY ON BREAK

## SBR/STR\*

Power must be applied to the input at all times prior to and during timing. Upon closure of the initiate switch, the output contacts transfer and remain transferred if no further action is taken. When the initiate switch is opened, the time delay begins. At the completion of the pre-selected delay period the output contacts revert to their original position. Closure of initiate during timing will reset the delay period. Removal of input power will reset the control.

\*STR is the same except it is trailing edge triggered. Load energizes when initiate switch is opened.

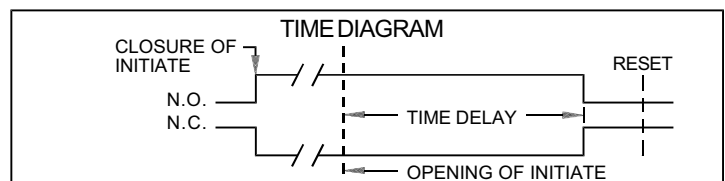

# RETRIGGERABLE ONE-SHOT

# SOR

Power must be applied to the input at all times prior to and during timing. Upon closure of the initiate switch (momentary or maintained) the output contacts transfer and the time delay begins. At the completion of the pre-selected delay period, the output contacts revert to their original position. **NOTE:** Momentary or maintained closure of initiate switch during timing will reset the delay.

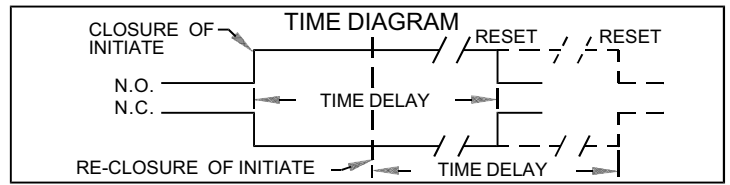

## DIMENSIONS

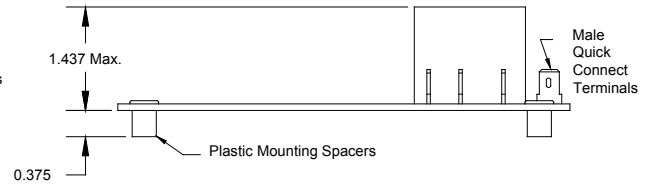
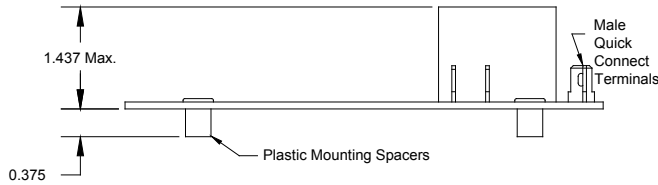
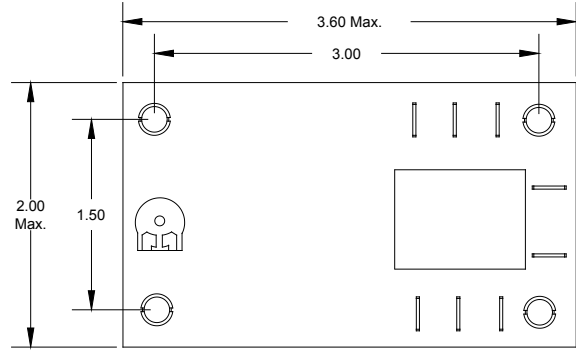
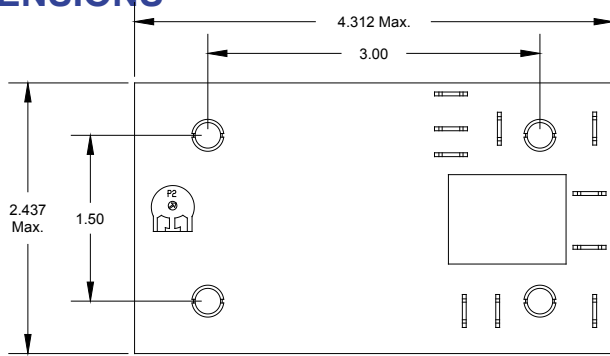

**SBR, SOR, SSR, STR**

**SIR, SMR**

## CONNECTION DIAGRAMS

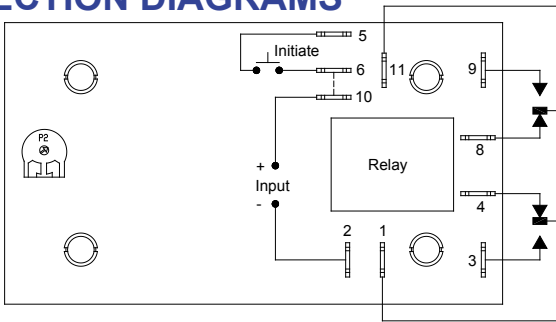

**SBR, SOR, SSR, STR  
Local Adjust**

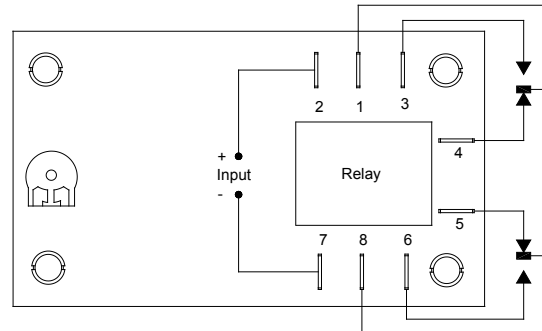

**SIR, SMR  
Local Adjust**

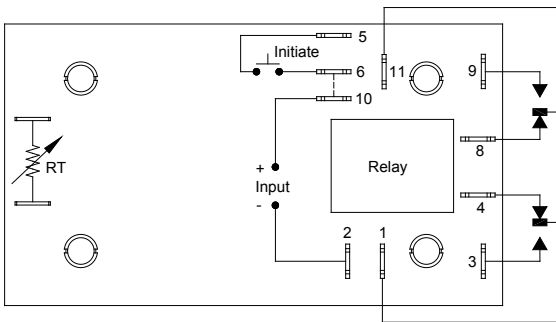

**SBR, SOR, SSR, STR  
Remote Adjust**

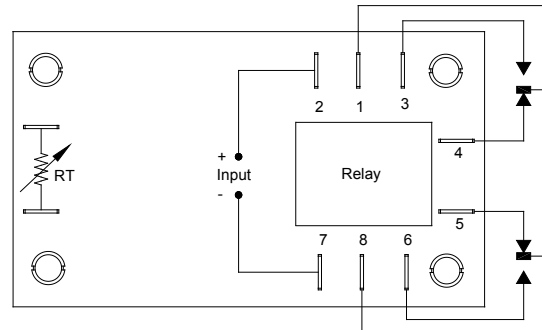

**SIR, SMR  
Remote Adjust**

## ORDERING INFORMATION

SERIES	TERMINATION	INPUT VOLTAGE	ADJUSTMENT	TIME DELAY RANGE
SBR	2 - 3/16" Quick Connect 3 - 1/4" Quick Connect	1 - 12 VDC	0 - Local Adjustment 1 - Fixed 2 - Remote Adjustment	See Time Delay Range Chart
SIR		2 - 24/28 VDC		
SMR		3 - 110 VDC		
SOR		4 - 24 VAC		
SSR		5 - 120 VAC		
STR		6 - 230 VAC		