

## 49 PCB Mount Enclosed Relay/SPDT 3 - 10 Amp Rated

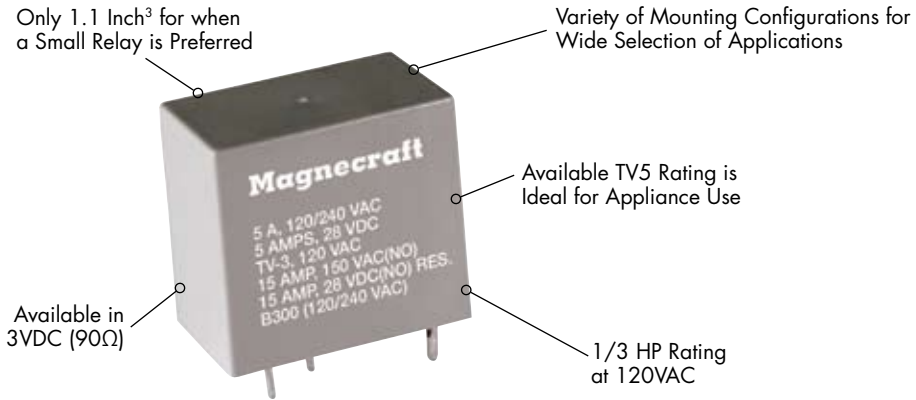

### General Specifications

(UL 508)

Contact Characteristics		Units	10 Amp SCO SPDT	
Number and type of Contacts			Normally Open	Normally Closed
Contact materials			Silver Alloy	
Current rating		A	15	10
Switching voltage		~ V	277 V 50/60 Hz	
		≡ V	28 V	
		HP	1/3 @ 240 VAC	1/6 @ 240 VAC
		HP	1/4 @ 277 VAC	1/8 @ 277 VAC
Minimum Switching Requirement		Pilot Duty mA	B300 (120/240 VAC) 100	
Coil Characteristics				
Voltage Range		≡ V	3...24	
Operating Range	% of Nominal	≡	75% to 120%	
Average consumption		≡ W	0.11	
Drop-out voltage threshold		≡	10%	
Performance Characteristics				
Electrical Life	Operations @ Rated Current (Resistive)		100,000	
Mechanical Life	Unpowered		50,000,000	
Operating time (response time)		ms	25	
Dielectric	Between coil and contact	~ V	2500	
	Between contacts	~ V	500	
Environment				
Product certifications	Standard version		UL	
Ambient air temperature around the device	Storage	°C	-40...+85	
	Operation	°C	-40...+55	
Vibration resistance	Operational	g-n	3, 10 to 55 Hz	
Shock resistance		g-n	10	
Weight		grams	42	



5 Amp SCO SPDT			3 Amp Silver SPDT		
Normally Open		Normally Closed	Normally Open		Normally Closed
	Silver Alloy			Fine Silver	
	5		15		3
	120 V 50/60 Hz			150 V 50/60 Hz	
	28 V			28 V	
1/3 @ 240 VAC		1/6 @ 240 VAC	1/3 @ 240 VAC		1/6 @ 240 VAC
1/4 @ 277 VAC		1/8 @ 277 VAC	1/4 @ 277 VAC		1/8 @ 277 VAC
	B300 (120/240 VAC)			B300 (120/240 VAC)	
	100			100	
	3...24		3...24		5...24
	75% to 120%			75% to 120%	
	0.11			0.11	
	10%			10%	
	100,000			100,000	
	50,000,000			50,000,000	
	25			25	
	2500			2500	
	500			500	
	UL			UL	
	-40...+85			-40...+85	
	-40...+55			-40...+55	
	3, 10 to 55 Hz			3, 10 to 55 Hz	
	10			10	
	42			42	

# 49 PCB Mount Enclosed Relay/SPDT 3 - 10 Amp Rated *continued*

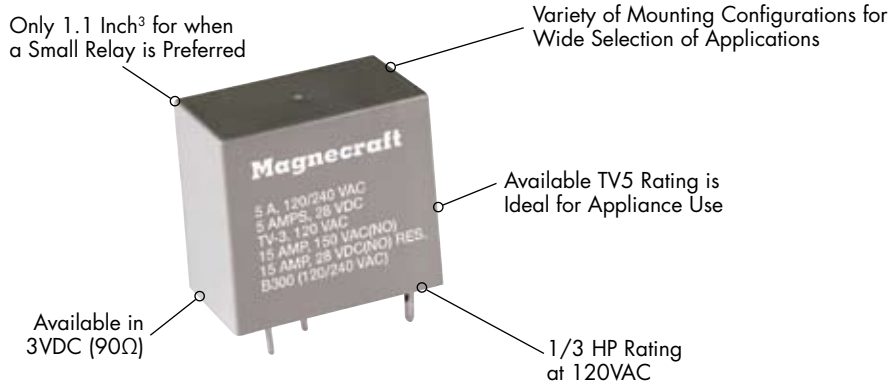

### Standard Part Numbers

### BOLD-FACED PART NUMBERS ARE NORMALLY STOCKED

Nominal Input Voltage 3 Amp, Style RE1C1	Nominal Coil Resistance (Ω)	Part Number	Contact Configuration
3 VDC	90 Ω	<b>W49RE1C1VG-3DC-SIL</b>	SPDT
5 VDC	235 Ω	<b>W49RE1C1VG-5DC-SIL</b>	SPDT
12 VDC	1350 Ω	<b>W49RE1C1VG-12DC-SIL</b>	SPDT
6 VDC	410 Ω	<b>W49RE1C2VF-6DC-SIL</b>	SPDT
12 VDC	1640 Ω	<b>W49RE1C2VF-12DC-SIL</b>	SPDT
24 VDC	6560 Ω	W49RE1C2VF-24DC-SIL	SPDT
<b>5 Amp, Style RE1C1 and RE1C2</b>			
5 VDC	235 Ω	W49RE1C1VG-5DC-SCO	SPDT
12 VDC	1350 Ω	<b>W49RE1C1VG-12DC-SCO</b>	SPDT
24 VDC	5400 Ω	<b>W49RE1C1VG-24DC-SCO</b>	SPDT
6 VDC	410 Ω	<b>W49RE1C2VF-6DC-SCO</b>	SPDT
12 VDC	1640 Ω	<b>W49RE1C2VF-12DC-SCO</b>	SPDT
24 VDC	6560 Ω	W49RE1C2VF-24DC-SCO	SPDT
<b>10 Amp, Style RE1C1</b>			
5 VDC	100 Ω	W49RE1C1VW-5DC-SCO	SPDT
12 VDC	600 Ω	W49RE1C1VW-12DC-SCO	SPDT
24 VDC	2400 Ω	W49RE1C1VW-24DC-SCO	SPDT
<b>10 Amp, Style R1C4</b>			
5 VDC	235 Ω	<b>W49R1C4VG-5DC-SCO</b>	SPDT
12 VDC	1350 Ω	<b>W49R1C4VG-12DC-SCO</b>	SPDT
<b>10 Amp, Style R1C4</b>			
5 VDC	100 Ω	<b>W49R1C4VW-5DC-SCO</b>	SPDT
24 VDC	2400 Ω	<b>W49R1C4VW-24DC-SCO</b>	SPDT

### Part Number Builder

Series	Footprint	Rating	Coil Voltage	Contact Material
49	RE1C1 = Narrow Footprint RE1C2 = Wide Footprint R1C4 = Top Mounting Bracket	VG = (RE1C1) 5A SCO or 3A Fine Silver VG (R1C4) = 10A SCO VF = (RE1C2) 5A SCO or 3A Fine Silver VW = 10A SCO	3DC = 3 VDC 5DC = 5 VDC 6DC = 6 VDC 12DC = 12 VDC 24DC = 24 VDC	SIL = Fine Silver Contacts SCO = Silver Alloy Contacts

### CIRCUIT BOARD PIN SPACING VIEWED FROM COMPONENT SIDE (TOP VIEW)

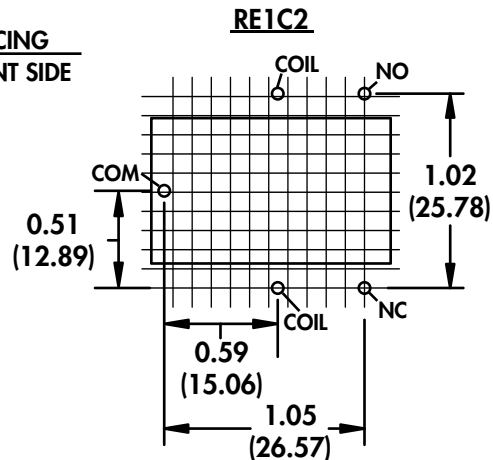
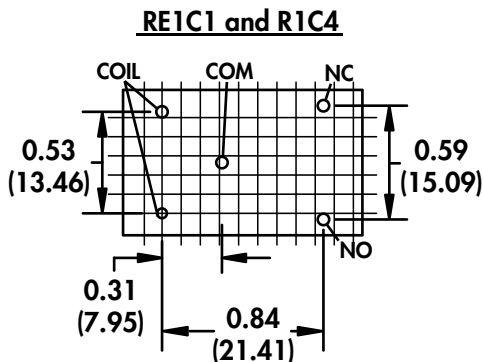

0.1 IN GRID  
(2.54 MM)

PIN SPACINGS SHOWN AT 100% OF ACTUAL SIZE

**STYLE RE1C1**

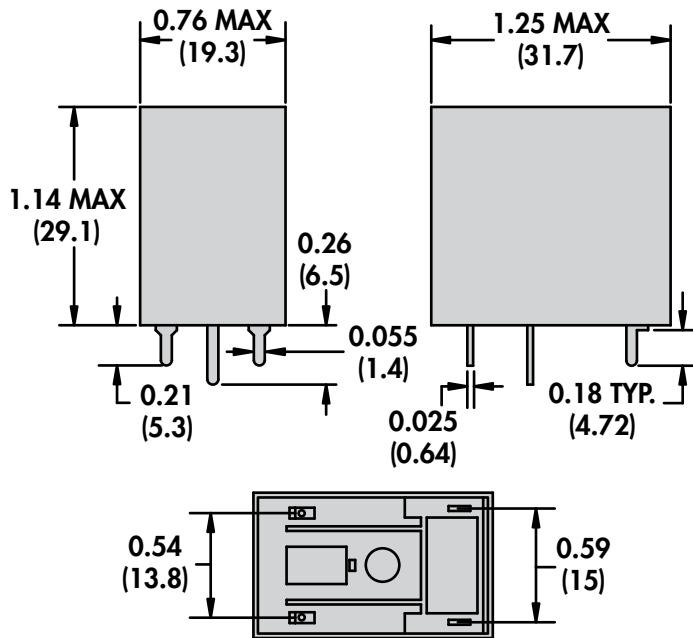

**STYLE RE1C2**

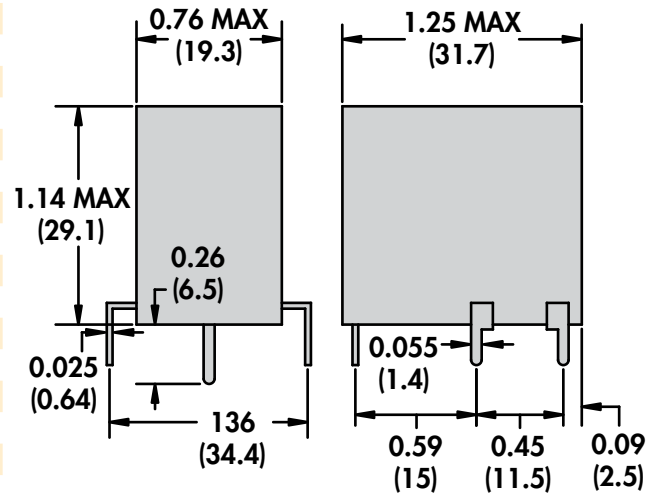

**STYLE R1C4**

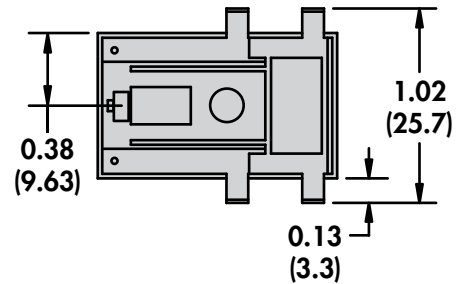
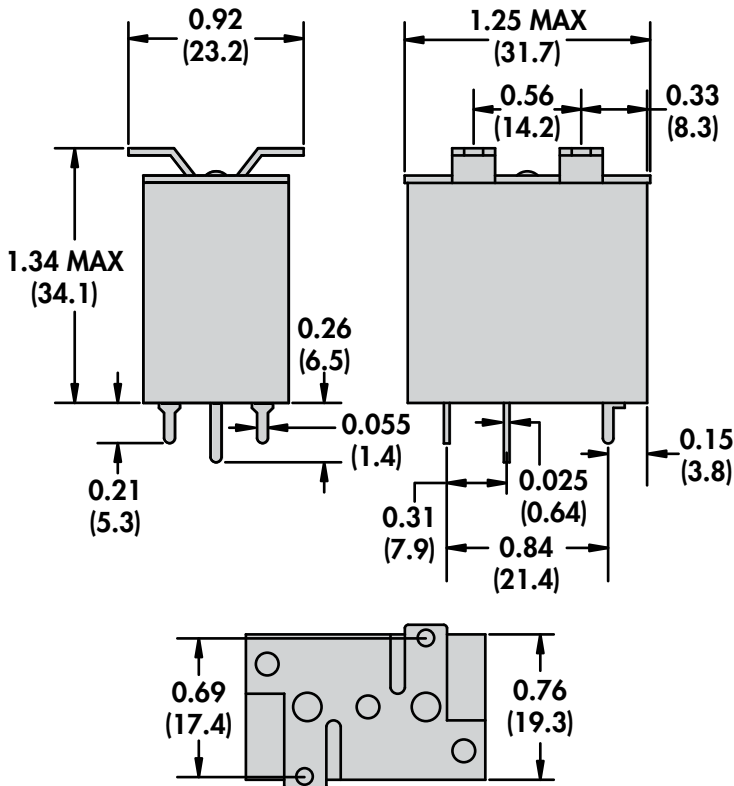

**WIRING DIAGRAMS  
TOP VIEW**

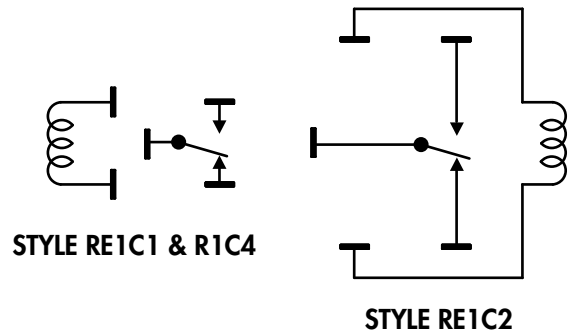

DRAWINGS SHOWN AT 100% OF ACTUAL SIZE