

Description

Legacy Time Delay and Sensor Relays

831 Series
SPDT, 15 A



831 Relay

Description

The 831 voltage sensor is a single-phase AC voltage sensing device capable of monitoring and reacting to overvoltage and undervoltage conditions. This product is designed to be wired across terminals A1 and A2 with the voltage being monitored.

The two LED lamps indicate when the input voltage is present (green LED) and when the output is energized (red LED).

The Umax dial is used to set the upper trip-point for the voltage sensor. The Umin dial is a percentage of the Umax dial and is used to set the lower trip-point for the voltage sensor. The timing dial is used to delay the transfer of the contacts, from 0–10 s, when a set point has been violated.

Feature	Benefit
Three-state indication LEDs	Indicate normal state and two types of faulted states
Timing dial	Adjustable delay 0–10 s
DIN mounting capability	Mounts directly on a 35 mm DIN rail
Current rating: 15 A @ 240 Vac, 24 Vdc	High switching capacity
Narrow width: 17.5 mm (0.69 in.)	Ideal for tight spaces

Nominal Input Voltage	Sensing Voltage Range	Timing Range	Contact Configuration	Rated Current	Standard Part Number
120 Vac	Upper: 85–150 Vac Lower: 30–99% of upper	0–10 s	SPDT	15 A	831VS-120A
240 Vac	Upper: 160–276 Vac Lower: 30–99% of upper				831VS-240A
24 Vdc	Upper: 18–30 V Lower: 30–99% of upper				831VS-24D

Part Number Explanation

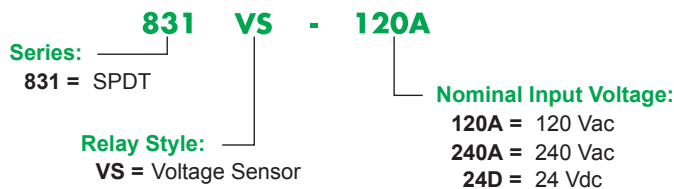

Legacy Time Delay and Sensor Relays

831 Series
SPDT, 15 A

Specifications

Part Number	831VS-120A	831VS-240A	831VS-24D
Input Characteristics			
Nominal Input Voltage	120 Vac	240 Vac	24 Vdc
Absolute Input Voltage Maximum	200 Vac	280 Vac	35 Vdc
Upper Supply Voltage Range	85–150 Vac	160–276 Vac	18–30 Vdc
Lower Supply Voltage Range	30–99% of upper preset	30–99% of upper preset	30–99% of upper preset
Maximum Power Consumption	1.2 VA	1.2 VA	1.2 W
Time Delay	adjustable, 0–10 s	adjustable, 0–10 s	adjustable, 0–10 s
Accuracy			
Mechanical Setting	5%	5%	5%
Repeat Accuracy	<1%	<1%	<1%
Temperature Variation	<1% / °C	<1% / °C	<1% / °C
Hysteresis (from fault to normal)	2–6% of adjusted value	2–6% of adjusted value	2–6% of adjusted value
Output Characteristics			
Contact Configuration	SPDT	SPDT	SPDT
Output Current Rating	15 A @ 120, 240 Vac, 24 Vdc	15 A @ 120, 240 Vac, 24 Vdc	15 A @ 120, 240 Vac, 24 Vdc
Breaking Capacity	4000 VA/AC1, 384 W/DC	4000 VA/AC1, 384 W/DC	4000 VA/AC1, 384 W/DC
Inrush Current	30 A / <3 s	30 A / <3 s	30 A / <3 s
Maximum Switching Voltage	250 Vac / 24 Vdc	250 Vac / 24 Vdc	250 Vac / 24 Vdc
Minimum Breaking Capacity DC	500 mW	500 mW	500 mW
Mechanical Life (1)	10,000,000 operations	10,000,000 operations	10,000,000 operations
Electrical Life (1)	70,000 operations	70,000 operations	70,000 operations
Contact Material	Silver alloy	Silver alloy	Silver alloy
Switching Capability	15 A @ 240 Vac, 50/60 Hz, 24 Vdc 1/2 hp @ 120 Vac 1 hp @ 240 Vac Pilot duty B300	15 A @ 240 Vac, 50/60 Hz, 24 Vdc 1/2 hp @ 120 Vac 1 hp @ 240 Vac Pilot duty B300	15 A @ 240 Vac, 50/60 Hz, 24 Vdc 1/2 hp @ 120 Vac 1 hp @ 240 Vac Pilot duty B300
Minimum Switching Requirement	100 mA at 5 Vac/Vdc	100 mA at 5 Vac/Vdc	100 mA at 5 Vac/Vdc
Timing/Sensing Characteristics			
Time Scales	1	1	1
Time Ranges	0–10 s	0–10 s	0–10 s
Tolerance	5% of mechanical setting	5% of mechanical setting	5% of mechanical setting
Repeatability at Constant Voltage and Temperature	1%	1%	1%
Upper Sensing Voltage Range	85–150 Vac	160–276 Vac	18–30 Vdc
Lower Sensing Voltage Range	30–99% of upper preset	30–99% of upper preset	30–99% of upper preset
General Characteristics			
Dielectric Strength (Input to Contacts)	2500 Vac	2500 Vac	2500 Vac
Dielectric Strength (Between Open Contacts)	1600 Vac	1600 Vac	1600 Vac
Mounting Position	Any, 35 mm DIN rail EN 50022	Any, 35 mm DIN rail EN 50022	Any, 35 mm DIN rail EN 50022
Overvoltage Category	III	III	III
Pollution Degree	2	2	2
Storage Temperature Range	–30 to +70 °C (–22 to +158 °F)	–30 to +70 °C (–22 to +158 °F)	–30 to +55 °C (–22 to +131 °F)
Operating Temperature Range	–20 to +55 °C (–4 to +131 °F)	–20 to +55 °C (–4 to +131 °F)	–20 to +55 °C (–4 to +131 °F)
Terminal Wire Capacity (Input and Output)	14 AWG (2.5 mm ²) maximum	14 AWG (2.5 mm ²) maximum	14 AWG (2.5 mm ²) maximum
Terminal Screw Torque	7.1 lb-in (0.8 N·m) maximum	7.1 lb-in (0.8 N·m) maximum	7.1 lb-in (0.8 N·m) maximum
Weight	62 g (2.19 oz)	62 g (2.19 oz)	88 g (3.10 oz)
Input Indication	Green LED		
Output Indication (Blinking = Timing; On = Energized)	Red LED		
Enclosure Rating (according to IEC 60529 IP rating)	IP40		
Approvals	UL (E234203, CCN: NKCR, NKCR7), CE (IEC 60947-1, 61000-4), RoHS		

(1) Actual product life varies based on electrical load, duty cycle, application, and environmental conditions.

Legacy Time Delay and Sensor Relays

831 Series
SPDT, 15 A

Dimensions—in. (mm)

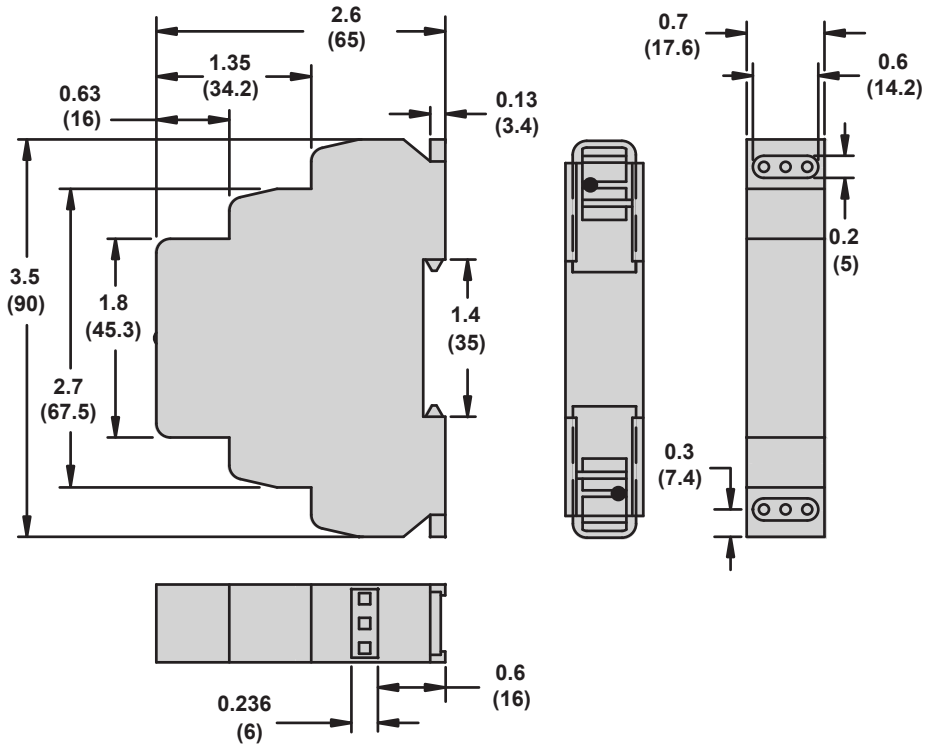

Wiring Diagram

