



Better. By Design.

ALTERNATING RELAYS



CATALOG OF PRODUCTS

ALTERNATING RELAYS

TYPICAL INSTALLATIONS

Alternating Relays are used in special applications where the optimization of load usage is required by equalizing the run time of multiple loads. Identical loads are used for the same job—a standby unit is available in case the first load fails. However, an idle load might deteriorate due to lack of use and provide no safety margin. Alternating relays prevent this by assuring that multiple loads get equal run time. In addition, there are situations where a need arises to have multiple loads on at the same time for additional capacity if one load cannot keep up with demand.

This alternating action is normally initiated by a control switch such as a float switch or pressure switch. Each time the initiating switch is opened, turning off a load, the alternating relay will change state, thus alternating the multiple loads.

Typical applications include pumps with float switches as the initiating contact or compressors with pressure switches or thermostats as the initiating contact.

Macromatic offers two types of Alternating Relays:

- **Duplex:** For controlling two loads, both plug-in & inner-door mounting, in SPDT, DPDT and DPDT Cross-Wired output configurations
- **Triplex:** For controlling three loads, plug-in mounting

TYPICAL INSTALLATIONS

Duplex SPDT & DPDT

In the off state, the Control Switch is open, the Alternating Relay is in the LOAD 1 position, and both LOAD 1 & LOAD 2 are off. The red LED marked "LOAD 1" is ON. When the Control Switch closes, it energizes LOAD 1. As long as the Control Switch remains closed, LOAD 1 remains energized. When the Control Switch opens, LOAD 1 is turned off and the Alternating Relay toggles to the LOAD 2 position. The red LED marked "LOAD 2" is ON. When the Control Switch closes again, it energizes LOAD 2. When the Control Switch opens, LOAD 2 is turned off, the Alternating Relay toggles back to the LOAD 1 position, the red LED marked "LOAD 1" is ON, and the process can be repeated.

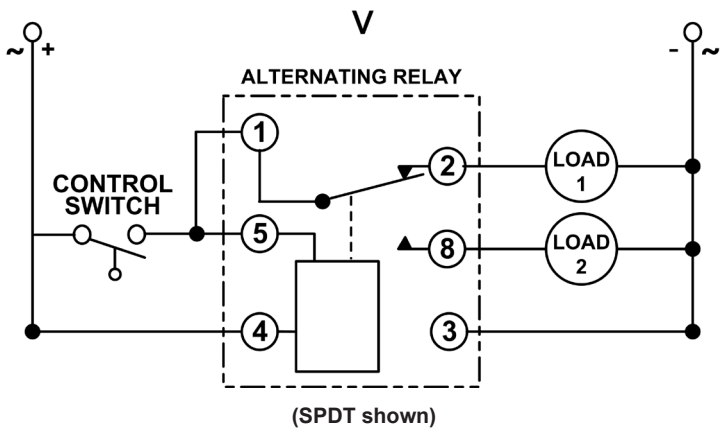

A DPDT Alternating Relay is the same as a SPDT but with an extra set of NO & NC contacts. As shown in to right, these extra contacts can be used for pilot lights or other indications.

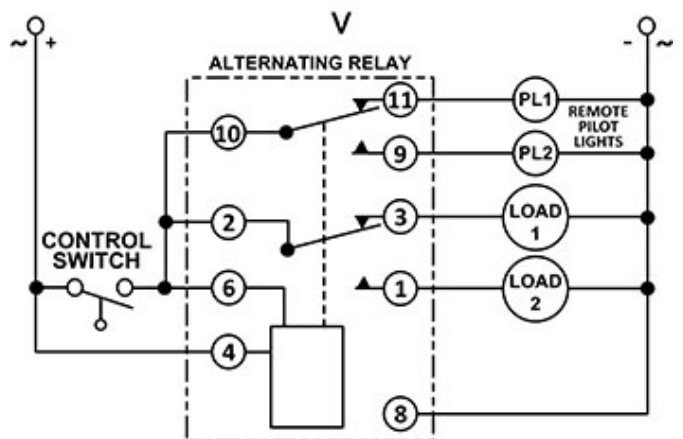

ALTERNATING RELAYS

TYPICAL INSTALLATIONS

TYPICAL INSTALLATIONS

Duplex DPDT Cross-Wired

In the off state, both the LEAD Switch and the LAG Switch are open, the Alternating Relay is in the LOAD 1 position, and both LOAD 1 & LOAD 2 are off. The red LED marked "LOAD 1" is ON. When the LEAD Switch closes, it energizes LOAD 1. As long as the LEAD Switch remains closed, LOAD 1 remains energized. If the LAG Switch closes, it energizes LOAD 2. When the LAG Switch opens, LOAD 2 is turned off. When the LEAD Switch opens, LOAD 1 is turned off and the Alternating Relay toggles to the LOAD 2 position. The red LED marked "LOAD 2" is ON. When the LEAD Switch closes, it turns on LOAD 2. If the LAG Switch closes, it will energize LOAD 1. When the LAG Switch opens, LOAD 1 is turned off. When the LEAD Switch opens, LOAD 2 is turned off, the Alternating Relay toggles back to the LOAD 1 position, the red LED marked "LOAD 1" is ON, and the process can be repeated. **NOTE:** the LEAD switch must always close before the LAG switch and must always open after the LAG switch.

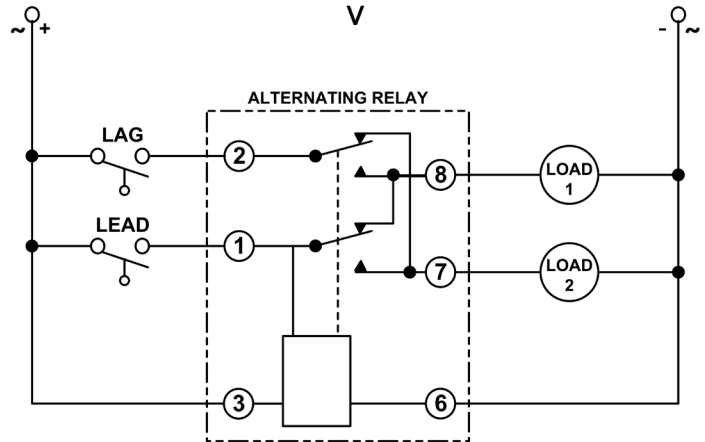

The diagram at right illustrates a type of operation known as "Sequence On - Simultaneously Off (S.O.S.O.)"-the two loads are energized sequentially, but remain on together until the OFF switch is opened. In the initial OFF state, all three switches are open, the Alternating Relay is in the LOAD 1 position, and both loads are off. No action happens with the Alternating Relay or either load when the OFF Switch closes. When the LEAD Switch closes, Load M1 turns on. When the LAG Switch closes, Load M2 turns on. Both loads remain on as long as all three switches are closed. When the LAG Switch opens, Load M2 remains on because the OFF Switch is still closed. When the LEAD Switch opens, Load M1 remains on because the OFF Switch is still closed. When the OFF Switch opens, both Load M1 and Load M2 are turned off simultaneously. The Alternating Relay toggles to the LOAD 2 position. The entire cycle is then repeated, but with Load M2 energized first followed by Load M1.

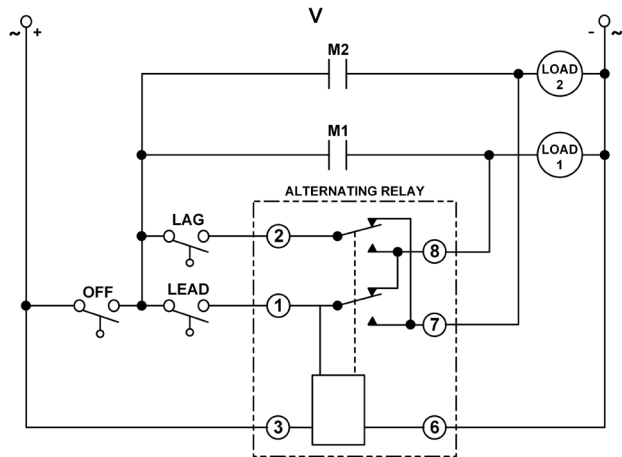

NOTE:

Both drawings shown are for DPDT Cross-Wired units with input voltage connected to Pins 3 & 6. For DPDT Cross-Wired units with input voltage connected to Pins 5 & 6, visit www.macromatic.com/ar-apps.

Triplexor

All three switches are open and all loads are off. When the LEAD Switch closes, it energizes LOAD 1. As long as the LEAD Switch remains closed, LOAD 1 remains energized. If the LAG Switch closes, LOAD 2 is energized. If the LAG2 Switch closes, it energizes LOAD 3. Each load is turned off in sequence as the switches are opened. The entire cycle is then repeated, but with LOAD 2 energized first followed by LOAD 3 and then LOAD 1. **NOTE:** Power for outputs is supplied from L connection, not through input switches.

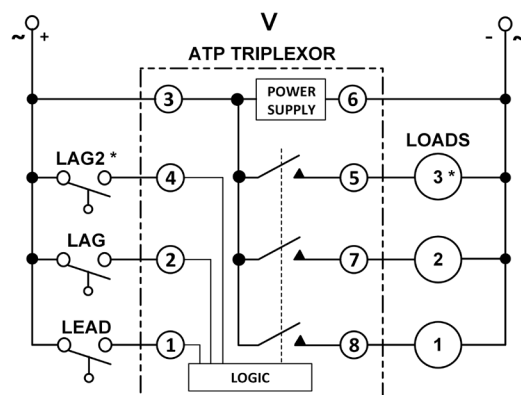

* NON FUNCTIONAL IN DUPLEX MODE ON "R" PRODUCTS

Drawing references terminal numbers on 8 pin products

SPDT & DPDT DUPLEXOR

ARP SERIES



- ◆ For Duplex Control of two loads
- ◆ Control voltages of 12 & 24V AC/DC and 120 & 240V AC
- ◆ Compact plug-in design utilizing industry-standard 8 or 11 pin octal socket
- ◆ 10A SPDT or DPDT Output Configuration
- ◆ Optional low profile selector switch for normal alternation or to lock either load to be ON only
- ◆ 2 LEDs indicate load to energize next
- ◆ Pilot Duty Rating



Better. By Design.

800.238.7474
WWW.MACROMATIC.COM
SALES@MACROMATIC.COM

Alternating Relays are used in applications where the optimization of load usage is required by equalizing the run time of two loads. This alternating action is initiated by a control switch, such as a float switch, manual switch, timing relay, pressure switch, or other isolated contact. Each time the initiating switch is opened, the output relay contacts will change state, thus alternating the two loads. Two LEDs indicate which load is the next to energize.

These Alternating Relays are available in either SPDT or DPDT output configurations and typically are used to control two loads, with only one on at a time. For products used when additional capacity is required (ability to turn both loads on at the same time), see Alternating Relays with DPDT Cross-Wired output configurations.

Each version is available with an optional three-position selector switch. This allows the unit to alternate the two loads as normal or select one or the other load to be the only one energized when the control switch closes. A load that has fewer hours than the other load could be used more often to eventually balance the run time of both loads. The selector switch has a low-profile to prevent any accidental changes in status.

For typical applications and detailed connection diagrams, visit: www.macromatic.com/ar-apps.

| OUTPUT CONTACTS | CONTROL VOLTAGE | CATALOG NUMBER | WIRING/SOCKET |
|---|---|--|---|
| SPDT Without Selector Switch 240V AC | 12V AC/DC 24V AC/DC 120V AC ARP240A6 | ARP012A6 ARP024A6 ARP120A6 | 8 Pin Octal 70169-D DIAGRAM 17 |
| SPDT With Selector Switch | 12V AC/DC 24V AC/DC 120V AC 240V AC | ARP012A6R ARP024A6R ARP120A6R ARP240A6R | |
| DPDT Without Selector Switch | 12V AC/DC 24V AC/DC 120V AC 240V AC | ARP012A2 ARP024A2 ARP120A2 ARP240A2 | 11 Pin Octal 70170-D DIAGRAM 18 |
| DPDT With Selector Switch | 12V AC/DC 24V AC/DC 120V AC 240V AC | ARP012A2R ARP024A2R ARP120A2R ARP240A2R | |

See page 14 for Available Sockets & Accessories

SPDT & DPDT DUPLEXOR

ARP SERIES

APPLICATION DATA

Voltage Tolerances: AC Operation: +10/-15% of nominal at 50/60 Hz; DC Operation: +10/-15% of nominal.

Load (Burden): Less than 3VA

Output Contacts:

10A @ 240V AC/24V DC,
1/2HP @ 120/240V AC (N.O.), 1/3HP @ 120/240VAC (N.C.)
B300, R300 (N.O.) Pilot Duty

Life:

Mechanical: 10,000,000 operations
Full Load: 100,000 operations

Temperature: Operating: -28° to 65°C (-18° to 149°F)
Storage: -40° to 85°C (-40° to 185°F)

Indicator LEDs: 2 LEDs marked LOAD 1 and LOAD 2

Optional Selector Switch Settings:

LOAD 1
ALTERNATE
LOAD 2

Approvals:

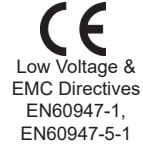

DIMENSIONS

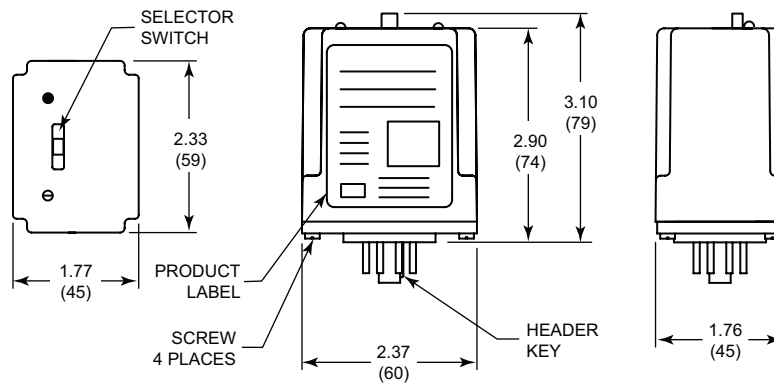

All Dimensions in Inches (Millimeters)

DPDT CROSS-WIRED DUPLEXOR

ARP SERIES

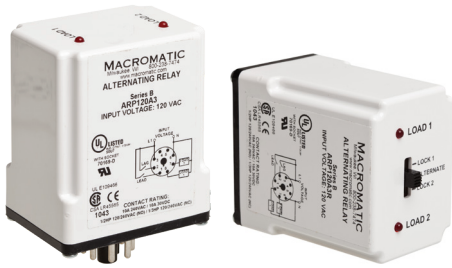

- ◆ For Duplex Control of two loads
- ◆ 10A DPDT Cross-Wired Output Configuration when additional capacity is required
- ◆ Control voltages of 12 & 24V AC/DC and 120 & 240V AC
- ◆ Compact plug-in design utilizing industry-standard 8 pin octal socket, or 12-pin square base.
- ◆ Optional low profile selector switch for normal alternation or to lock either load to be ON first
- ◆ Two LEDs indicate load to energize first
- ◆ Pilot Duty Rating



Better. By Design.

800.238.7474
WWW.MACROMATIC.COM
SALES@MACROMATIC.COM

Alternating Relays with DPDT cross-wired outputs are used in applications requiring both (a) the optimization of load usage by equalizing the run time of two loads and (b) additional capacity in case of excess load requirements. This alternating action is initiated by a control switch, such as a float switch, manual switch, timing relay, pressure switch, or other isolated contact. Each time the initiating switch is opened, the output relay contacts will change state, thus alternating the two loads. Two LEDs indicate which load will energize first.

Alternating Relays with DPDT cross-wired output configurations are typically used to control two loads when the need to have both loads on at the same time for additional capacity is required.

An optional three position selector switch is offered. This allows a DPDT cross-wired unit to alternate the two loads as normal, or lock the relay to always operate the same load first each time. A load that has fewer hours of operation than the other load could be used more often to eventually balance the run time of both loads. For typical applications and detailed connection diagrams, visit: www.macromatic.com/ar-apps.

| OUTPUT CONTACTS | CONTROL VOLTAGE | CATALOG NUMBER | WIRING/SOCKET |
|---|--|--|-------------------------------------|
| DPDT CROSS-WIRED Without Selector Switch | 12V AC/DC 24V AC/DC 120V AC 240V AC | ARP012A3 ARP024A3 ARP120A3 ARP240A3 | 8 Pin Octal 70169-D |
| DPDT CROSS-WIRED With Selector Switch | 12V AC/DC 24V AC/DC 120V AC 240V AC | ARP012A3R ARP024A3R ARP120A3R ARP240A3R | |
| DPDT CROSS-WIRED Without Selector Switch | 12V AC/DC 24V AC/DC 120V AC 240V AC | ARP012A5 ARP024A5 ARP120A5 ARP240A5 | 8 Pin Octal 70169-D |
| DPDT CROSS-WIRED With Selector Switch | 12V AC/DC 24V AC/DC 120V AC 240V AC | ARP012A5R ARP024A5R ARP120A5R ARP240A5R | |
| DPDT CROSS-WIRED Without Selector Switch | 24V AC/DC 120V AC | ARP024A4 ARP120A4 | 12 Pin Square SD12-PC |
| DPDT CROSS-WIRED With Selector Switch | 24V AC/DC 120V AC | ARP024A4R ARP120A4R | |

See page 14 for Available Sockets & Accessories

DPDT CROSS-WIRED DUPLEXOR

ARP SERIES

APPLICATION DATA

Voltage Tolerances: AC Operation: +10/-15% of nominal at 50/60 Hz; DC Operation: +10/-15% of nominal.

Load (Burden): Less than 3VA

Output Contacts:

10A @ 240V AC/24V DC,
1/2HP @ 120/240V AC (N.O.), 1/3HP @ 120/240VAC (N.C.)
B300, R300 (N.O.) Pilot Duty

Life:

Mechanical: 10,000,000 operations
Full Load: 100,000 operations

Temperature: Operating: -28° to 65°C (-18° to 149°F)
Storage: -40° to 85°C (-40° to 185°F)

Indicator LEDs: 2 LEDs marked LOAD 1 and LOAD 2

Optional Selector Switch Settings:

LOAD 1 (always energizes first)
ALTERNATE
LOAD 2 (always energizes first)

Approvals:

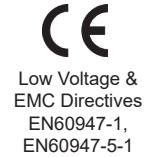

DIMENSIONS

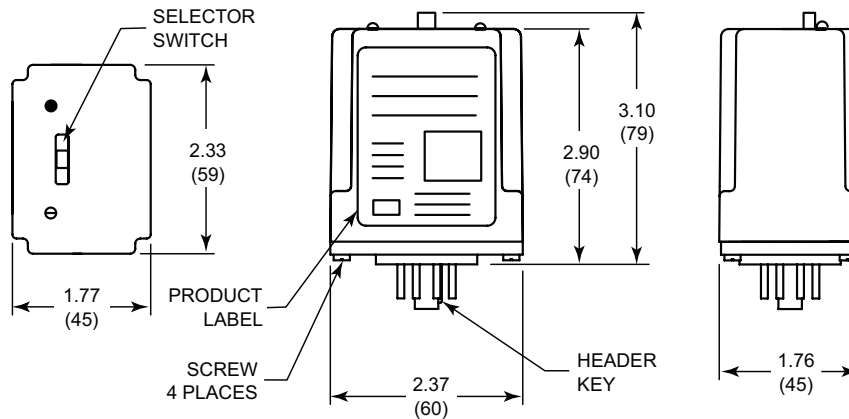

ARP Series 8-pin Plug-In

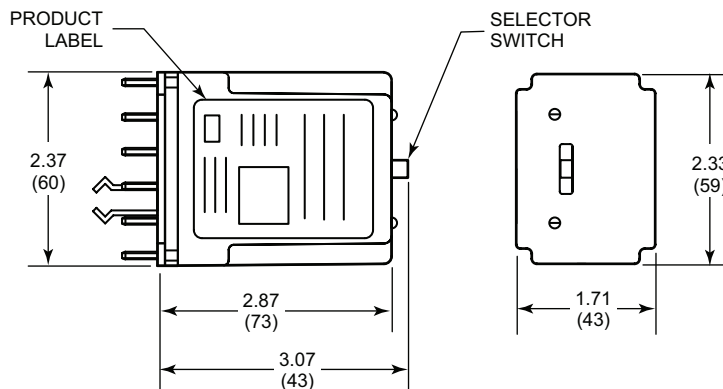

ARP Series 12-pin Square Mounting

All Dimensions in Inches (Millimeters)

SPDT & DPDT CROSS-WIRED DUPLEXOR

ARF SERIES

ALTERNATING RELAYS | INNER DOOR MOUNTING



- ◆ For Duplex Control of two loads
- ◆ Both SPDT Output & DPDT Cross-Wired Output
- ◆ Control voltages of 12 & 24V AC/DC and 120 & 240V AC
- ◆ Flange-enclosure designed for deadfront door-mounting
- ◆ Low profile selector switch for normal alternation or to lock either load ON first
- ◆ Selector switch accessible without opening inner door
- ◆ 2 LEDs indicate relay status
- ◆ 8 Pin Back-Mounted socket provided with relay
- ◆ Pilot Duty Rating



Better. By Design.

800.238.7474

WWW.MACROMATIC.COM

SALES@MACROMATIC.COM

Alternating Relays are used in applications requiring the optimization of load usage by equalizing the run time of two loads. A version with DPDT Cross-Wired output is also used for additional capacity in case of excess load requirements. This alternating action is initiated by a control switch, such as a float switch, manual switch, timing relay, pressure switch, or other isolated contact. Each time the initiating switch is opened, the output relay contacts will change state, thus alternating the two loads.

A three-position selector switch is included. For SPDT versions, this allows the unit to alternate the two loads as normal or select one or the other load to be the only one energized when the control switch closes. For DPDT cross-wired versions, the switch provides the option to alternate the two loads as normal or select which load always comes on first when the LEAD switch closes. In either case, a load that has fewer hours of operation than the other load could be used more often to eventually balance the run time of both loads. The low-profile selector switch prevents any accidental changes in status.

These products utilize a flange-enclosure designed to be deadfront-mounted on an inner door and used with back-mounted sockets. Everything needed for setup, use and troubleshooting is on the top of the unit: LED status indication and low-profile selector switch. With this product, the selector switch can be moved to any position without having to open the inner door.

For typical applications and detailed connection diagrams, visit: www.macromatic.com/ar-apps.

| OUTPUT CONTACTS | CONTROL VOLTAGE | CATALOG NUMBER | WIRING/SOCKET ■ |
|---|--|--|--|
| SPDT w/ Selector Switch | 12V AC/DC 24V AC/DC 120V AC 240V AC | ARF012A6R ARF024A6R ARF120A6R ARF240A6R | 8 Pin Octal SR6P-M08G ■ LOAD 1: PIN 2 LOAD 2: PIN 8 DIAGRAM 17 |
| DPDT CROSS-WIRED w/ Selector Switch | 12V AC/DC 24V AC/DC 120V AC 240V AC | ARF012A3R ARF024A3R ARF120A3R ARF240A3R | 8 Pin Octal SR6P-M08G ■ DIAGRAM 19 |

■ 8 Pin Back-Mounted Socket provided with relay

See page 14 for Available Sockets & Accessories

SPDT & DPDT CROSS-WIRED DUPLEXOR

ARF SERIES

APPLICATION DATA

Voltage Tolerance:

AC Operation: +10/-15% of nominal at 50/60 Hz.

DC Operation: +10/-15% of nominal.

Load (Burden): Less than 3VA

Output Contacts:

10A @ 240V AC/24V DC,

1/2HP @ 120/240V AC (N.O.), 1/3HP @ 120/240VAC (N.C.)

B300, R300 (N.O.) Pilot Duty

Life:

Mechanical: 10,000,000 operations

Full Load: 100,000 operations

Temperature: Operating: -28° to 65°C (-18° to 149°F)

Storage: -40° to 85°C (-40° to 185°F)

Indicator LEDs: 2 LEDs marked LOAD 1 and LOAD 2

Optional Selector Switch Settings:

LOAD 1

ALTERNATE

LOAD 2

Approvals:

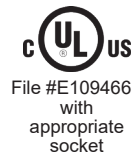
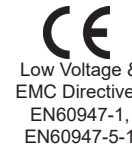

DIMENSIONS

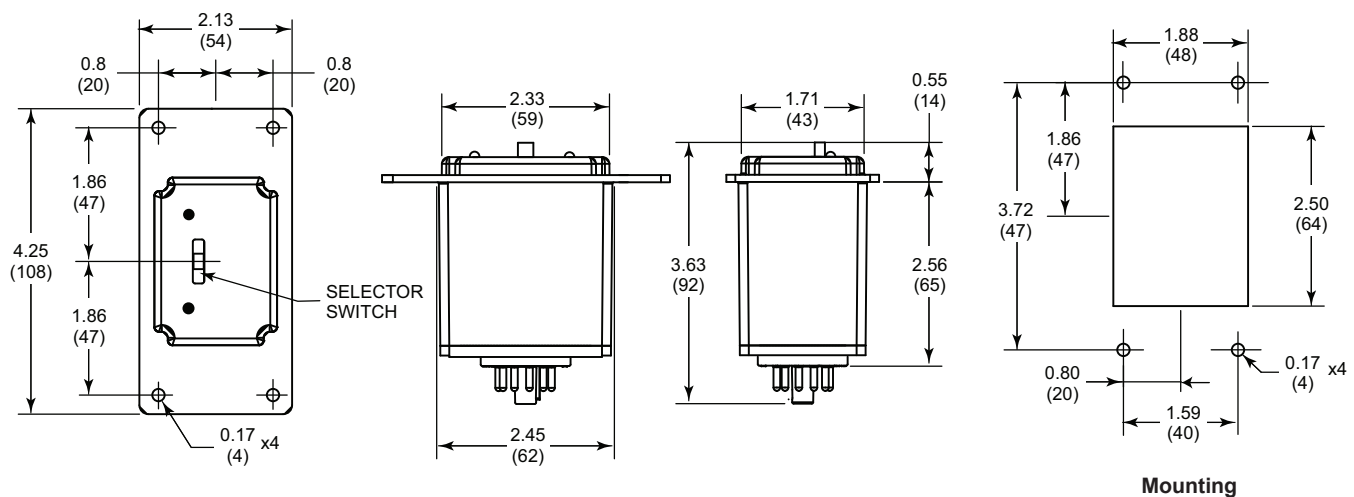

All Dimensions in Inches (Millimeters)

ALTERNATING RELAYS | INNER DOOR MOUNTING

DUPLEX CONTROLLERS

3 FLOAT SWITCH INPUTS FOR S.O.S.O. | ARP AND ARF SERIES

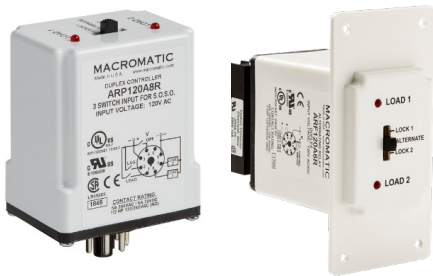

- ◆ Combines functions of alternating relay, control relay & auxiliary contacts in one unit--saves money
- ◆ Offers Sequence On - Simultaneous OFF (S.O.S.O.) Operation with three float switch inputs
- ◆ Protects against failures of both OFF & LEAD switches
- ◆ Plug-in design (ARP Series) utilizes industry-standard 8 pin octal socket saving space over separate components
- ◆ Flange-enclosure (ARF Series) designed for deadfront door-mounting
- ◆ Low profile selector switch for normal alternation or to lock either load to be ON first
- ◆ 2 LEDs indicate load to energize first



Better. By Design.

800.238.7474

WWW.MACROMATIC.COM

SALES@MACROMATIC.COM

Many duplex pump applications require Sequence On – Simultaneous OFF operation with three float switch inputs and alternation of which pump is turned on first. The two loads are energized sequentially when the LEAD & LAG switches close, but remain on together until the OFF switch is opened.

Normally, this is all done with a separate alternating relay, a control relay and two auxiliary contacts. Macromatic Duplex Controllers combine the function of these individual components in one plug-in product utilizing an 8-pin socket. This reduces the cost of the control panel by saving space, reducing the number of components and minimizing assembly labor.

A low profile, three-position switch is provided to alternate the two loads as normal or lock the relay to always operate the same load first each time.

Operation

In the initial OFF state, all three switches are open, the Duplex Pump Controller is in the LOAD 1 position, and both loads are off (see Diagram right). No action happens with the Controller or either load when the OFF switch closes.

When the LEAD Switch closes, LOAD 1 turns on. When the LAG Switch closes, LOAD 2 turns on. Both loads remain on as long as all three switches are closed. When the LAG Switch opens, LOAD 2 remains on because the Duplex Controller simulates the function of an auxiliary contact. When the LEAD Switch opens, LOAD 1 remains on for the same reason. When the OFF Switch opens, both LOAD 1 and LOAD 2 are turned off simultaneously because all voltage is removed to both loads. The Duplex Controller toggles to the LOAD 2 position. The entire cycle is then repeated, but with LOAD 2 energized first followed by LOAD 1.

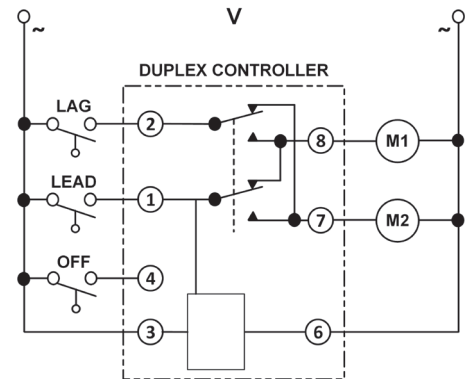

These products protect against failure of the OFF or LEAD Switches—if one or both of these switches fail to close in sequence, the two LOADS will be energized when the LAG switch closes. In addition, both LOADS are turned off simultaneously when the LAG switch opens.

| MOUNTING | CONTROL VOLTAGE | CATALOG NUMBER | WIRING/SOCKET |
|----------|----------------------|------------------------|---|
| PLUG-IN | 24V AC/DC 120V AC | ARP024A8R ARP120A8R | <p>8 Pin Octal ARP Series: 70169-D ARF Series: IDEC SR6P-M08G</p> <p style="text-align: center;">DIAGRAM 58</p> |
| FLANGE | 24V AC/DC 120V AC | ARF024A8R ARF120A8R | |

Sockets & Accessories available

DUPLEX CONTROLLERS

3 FLOAT SWITCH INPUTS FOR S.O.S.O. | ARP AND ARF SERIES

APPLICATION DATA

Voltage Tolerances:

AC Operation: +10/-15% of nominal at 50/60 Hz.

DC Operation: +10/-15% of nominal.

Load (Burden): Less than 3VA

Output Contacts: 5A@120V AC/24V DC, B300

Life:

Mechanical: 10,000,000 operations

Full Load: 100,000 operations

Temperature: Operating: -28° to 65°C (-18° to 149°F)

Storage: -40° to 85°C (-40° to 185°F)

Indicator LEDs: 2 LEDs marked LOAD 1 and LOAD 2

Selector Switch Settings:

LOAD 1 (always energizes first)

ALTERNATE

LOAD 2 (always energizes first)

Approvals:



DIMENSIONS

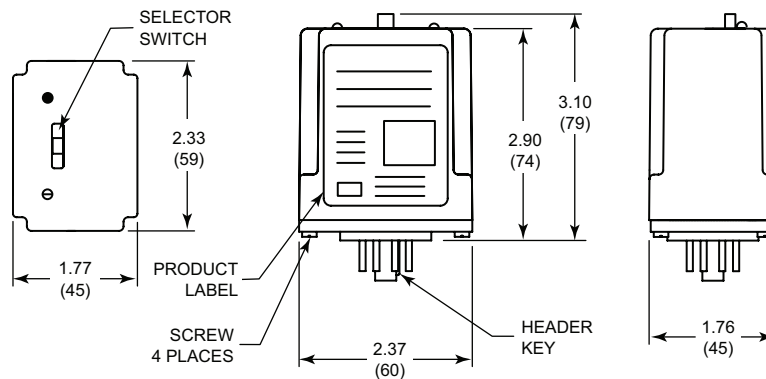

ARP Series 8-pin Plug-In

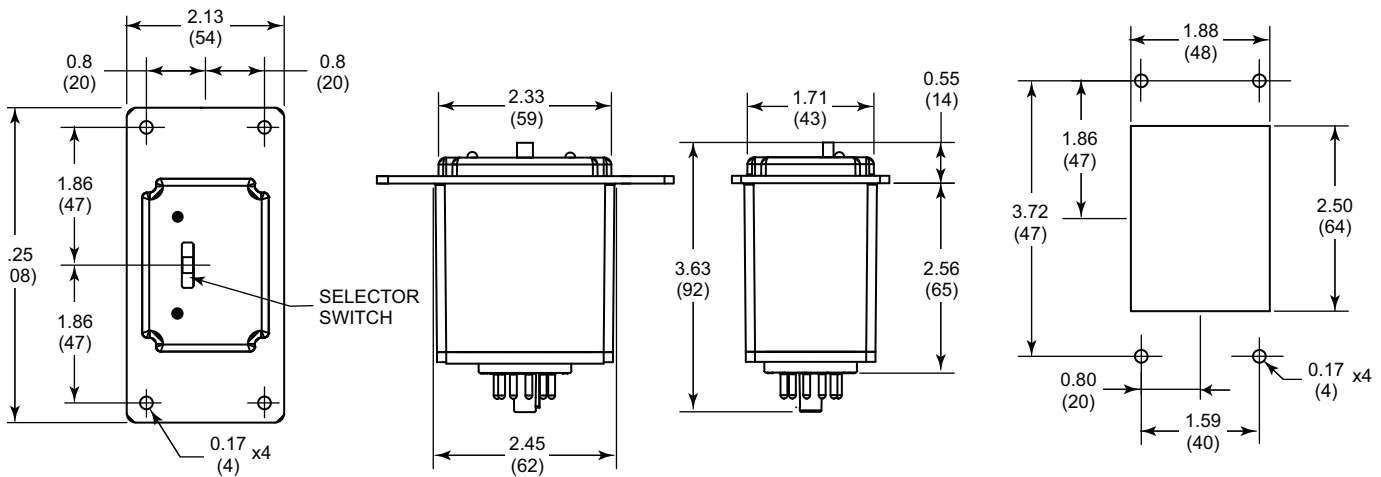

ARF Series Flange

Mounting

All Dimensions in Inches (Millimeters)

TRIPLEXOR

ATP SERIES



- ◆ For Triplex Control of three loads
- ◆ Works with 3 Switch inputs- LEAD, LAG & LAG2
- ◆ Optional top-mounted switch allows use as standard Triplexor or as Duplexor until system expansion requires additional third Load
- ◆ Control voltages of 120V AC or 24V AC/DC
- ◆ Plug-in enclosure utilizes industry-standard 8 Pin octal or 12 Pin square sockets
- ◆ Input Switch Failure Indication
- ◆ Pilot Duty Rating



with appropriate socket



Better. By Design.

800.238.7474

WWW.MACROMATIC.COM

SALES@MACROMATIC.COM

Macromatic ATP Series Triplexors are used in three load applications requiring both the optimization of load usage by equalizing the run time of multiple loads and additional capacity in case of excess load requirements.

As standard, these products operate as a normal Triplexor with three inputs. An optional version with an 8-position rotary switch is offered. This allows the unit to operate as either a:

- standard Triplexor
- Tripplexor locking Load 1, 2 or 3 as the first to be energized (Lead Load)
- standard Duplexor until system expansion requires control for a third Load
- Duplexor locking Load 1 or 2 as the first to be energized (Lead Load)

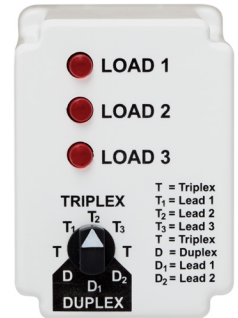

All versions offer an indication of a switch failure (out-of-sequence) - LEDs will flash if any switch closes out of sequence. Also, if power is lost and returns with more than just the LEAD Switch closed, there is a fixed 10 second delay between energization of the first output and subsequent outputs to prevent all Loads from coming on at the same time.

| FUNCTION | CONTROL VOLTAGE | CATALOG NUMBER | WIRING/SOCKET |
|--------------------------------------|----------------------|------------------------|---|
| TRIPLEXOR/ DUPLEXOR w/o Switch | 120V AC 24V AC/DC | ATP120A1 ATP024A1 | 8 Pin Octal 70169-D DIAGRAM 184 |
| TRIPLEXOR/ DUPLEXOR w/ Switch | 120V AC 24V AC/DC | ATP120A1R ATP024A1R | DIAGRAM 184 |
| TRIPLEXOR/ DUPLEXOR w/ Switch | 120V AC 24V AC/DC | ATP120A7R ATP024A7R | 12 Pin Square SD12-PC DIAGRAM 185 |

TRIPLEXOR

ATP SERIES

APPLICATION DATA

Voltage Tolerances: +10%/-15% at 50/60Hz. (AC);
+10%/-15% of control voltage (DC)

Load (Burden): Less than 2VA for all voltages

Output Contacts: (3) SPNO 3A @ 24/120V AC General Purpose;
C300 Pilot Duty; 1/6HP @ 24/120VAC

Life:

Mechanical: 10,000,000 operations;
Full Load: 100,000 operations

Temperature: Operating: -28° to 65°C (-18° to 149°F)
Storage: -40° to 85°C (-40° to 185°F)

Time Delay: If power is lost & returns with more than just the LEAD Switch closed, there is a fixed 10 second delay between energization of the second output (Triplex & Duplex mode) & third output (Triplex mode only) to prevent all Loads from coming on at the same time.

LED Indication: One of the Red LEDs will be steady ON to indicate which Load will be energized first; all will flash (3 in Triplex mode or 2 only in Duplex mode) to indicate a switch out-of-sequence error.

Optional Selector Switch Settings:

Allows unit to operate as standard Triplexor or Duplexor, or lock selected Loads to operate first (Lead Load) each time:

- | | |
|-----------------|----------------|
| Triplex | Duplex |
| Triplex--Lead 1 | Duplex--Lead 1 |
| Triplex--Lead 2 | Duplex--Lead 2 |
| Triplex--Lead 3 | |

Approvals:  US
File #E109466

 LISTED
IND. CONT. EQUIP.
5017
with appropriate socket
File #E109466

DIMENSIONS

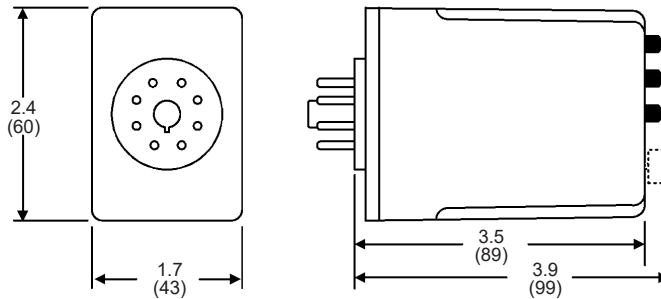

ATP Series 8-pin Plug-In

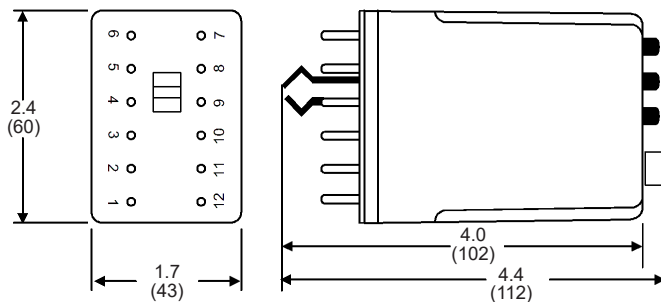

ATP Series 12-pin Square Mounting

All Dimensions in Inches (Millimeters)

SOCKETS & ACCESSORIES

8 Pin Octal Socket- Surface or DIN Rail-Mounted

- ◆ 10A @ 600V
- ◆ 1 or 2 #12-20 AWG Wire
- ◆ Pressure Wire Clamp Terminations
- ◆ Recommended Tightening Torque
12 in-lbs



File #E169693 File #LR701114



Catalog Number:
70169-D

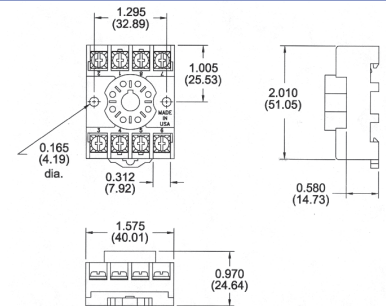
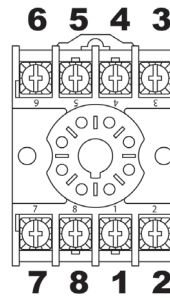

11 Pin Octal Socket Surface or DIN Rail-Mounted

- ◆ 10A @ 300V
- ◆ 1 or 2 #12-20 AWG Wire
- ◆ Pressure Wire Clamp Terminations
- ◆ Recommended Tightening Torque
12 in-lbs



File #E169693 File #LR701114



Catalog Number:
70170-D

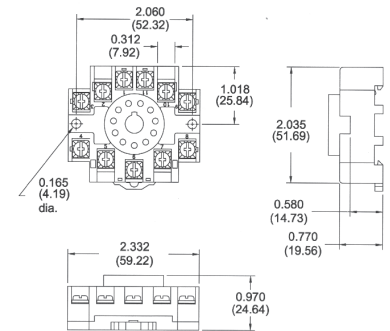
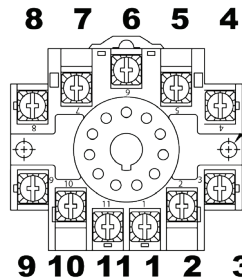

8 Pin Octal Socket- Back-Mounted

- ◆ 10A @ 300V
- ◆ Pressure Wire Clamp Terminations
- ◆ Recommended Tightening Torque
of 10 in-lbs



File #E62437

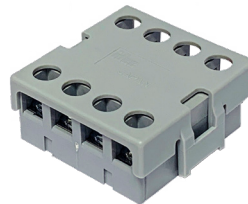

Catalog Number:
SR6P-M08G

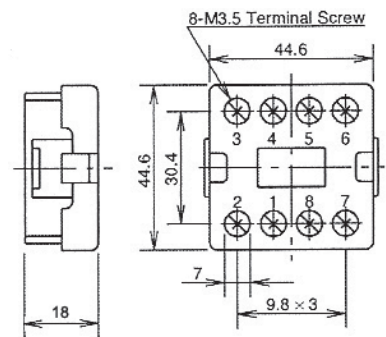

12 Pin Socket Surface-Mounted

- ◆ 10A @ 600V
- ◆ #12-20 AWG Wire
- ◆ Pressure Wire Clamp Terminations
- ◆ Recommended Tightening Torque
12 in-lbs

NOTE: If a 12 Pin Socket is required for DIN-rail mounting, please contact Macromatic.



File #LR29513

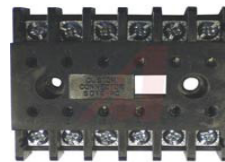

Catalog Number:
SD12-PC

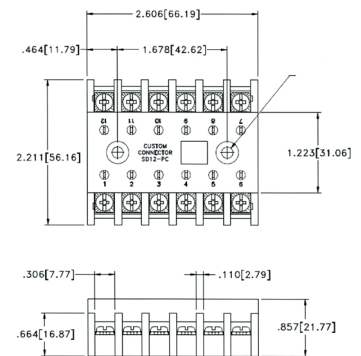

Hold Down Spring

Can be used for:

- ◆ Panel-Mounted Sockets
- ◆ Sockets Mounted to 35mm DIN Rail *

* Requires two #8, 3/4" length machine screws with washers & nuts--contact Macromatic or www.macromatic.com/70166 for more information.



Catalog Number:
70166



Your source for quality, innovative industrial control solutions

Macromatic Industrial Controls, Inc. designs and manufactures control, monitoring and protection products to manage your electrical processes and to protect your equipment from damaging fault conditions.

With a 45-year legacy of high-quality products and outstanding customer service, we continue to introduce innovative solutions that help our customers be more productive and efficient.

Our design and application experience makes it easy to find cost-effective advantages for your applications.

We continuously improve our products by integrating new technology and improving our manufacturing processes. The result is innovative reliable products, delivered on-time, every time.

www.macromatic.com

800.238.7474



Better. By Design.

800.238.7474 | www.macromatic.com | [SALES@MACROMATIC.COM](mailto:sales@macromatic.com)

Macromatic Industrial Controls Family of Products

MACROMATIC INDUSTRIAL CONTROLS

MACROMATIC
Better. By Design.

ALTERNATING RELAYS



800.238.7474 | www.macromatic.com | SALES@MACROMATIC.COM

CATALOG OF PRODUCTS

MACROMATIC
Better. By Design.

CURRENT SENSING RELAYS



800.238.7474 | www.macromatic.com | SALES@MACROMATIC.COM

CATALOG OF PRODUCTS

MACROMATIC
Better. By Design.

INTRINSICALLY SAFE PRODUCTS



MACROMATIC INDUSTRIAL CONTROLS, INC. | 800.238.7474 | www.macromatic.com | SALES@MACROMATIC.COM

CATALOG OF PRODUCTS

MACROMATIC
Better. By Design.

LIQUID LEVEL CONTROL RELAYS



800.238.7474 | www.macromatic.com | SALES@MACROMATIC.COM

CATALOG OF PRODUCTS

MACROMATIC
Better. By Design.

THREE-PHASE MONITOR RELAYS



800.238.7474 | www.macromatic.com | SALES@MACROMATIC.COM

CATALOG OF PRODUCTS

MACROMATIC
Better. By Design.

SEAL LEAKAGE & OVER TEMPERATURE RELAYS



800.238.7474 | www.macromatic.com | SALES@MACROMATIC.COM

CATALOG OF PRODUCTS

MACROMATIC
Better. By Design.

TIME DELAY RELAYS



800.238.7474 | www.macromatic.com | SALES@MACROMATIC.COM

CATALOG OF PRODUCTS

MACROMATIC
Better. By Design.

VOLTAGE MONITOR RELAYS



800.238.7474 | www.macromatic.com | SALES@MACROMATIC.COM

CATALOG OF PRODUCTS

MACROMATIC
Better. By Design.

PERCENTAGE TIMERS



800.238.7474 | www.macromatic.com | SALES@MACROMATIC.COM

CATALOG OF PRODUCTS



Better. By Design.

MACROMATIC
Better. By Design.

GENERAL PURPOSE RELAYS



MACROMATIC INDUSTRIAL CONTROLS, INC. | 800.238.7474 | www.macromatic.com | SALES@MACROMATIC.COM

CATALOG OF PRODUCTS

800.238.7474 | www.macromatic.com | SALES@MACROMATIC.COM

LCTAR00AEN0821