

MODEL 6010 - Two-Hand Machine Control

Designed to meet European standards for two-hand control devices (EN 574)

Model 6010 requires a machine operator to have both hands on start switches in order to begin a machine cycle. This minimizes the possibility of the operator having a hand in the work area when the machine starts. If one or both start switches are "tied-down", the output will not energize.

Model 6010 is specifically designed to meet the new OSHA and European safety standards which require that a single component failure will cause the control to shut down safely.

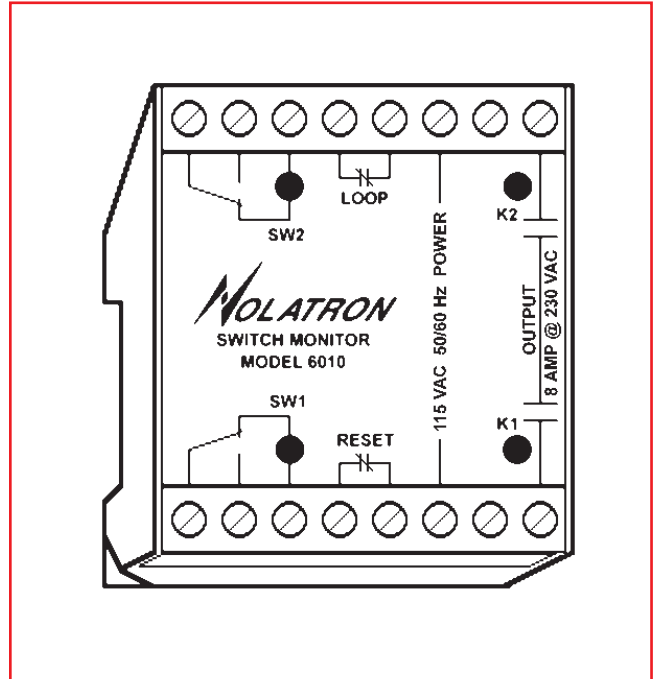

Positive Guided Output- The output consists of two relay contacts that are controlled by separate relays. Each relay is checked for proper status prior to beginning a machine cycle.

International Safety Compliance- The 6010 is designed to meet the European standards for two hand control devices (EN 574) and the United States OSHA classification of "control reliable" as defined in section 1910.217 (13).

CE Marking- Nolatron uses the CE Mark to designate that the 6010 is in compliance with the European standard for two-hand control devices (EN 574), and that it has been tested to emissions and immunity standards EN50081-1 and EN50082-1 and the Electromechanical Control Circuit Devices standard EN 60947-5-1. The use of CE marked components does not imply CE compliance of the finished product. The end user is responsible for determining that his machine is CE compliant. Additional testing may be required.

Four Status Indicators- The lights are used to aid installation, testing, and troubleshooting.

Versatile Enclosure- The enclosure can be panel mounted with two screws or snapped onto a DIN rail. Its small size uses little panel space (75L x 55W x 110D mm).

MODEL 6010 INSTALLATION

This control should be installed only by a person familiar with safety regulations and accident prevention. All operating conditions should conform to IEC 68-2-6. The control should be panel mounted (min IP 52) inside an enclosure suitable to protect the control from environmental contaminants.

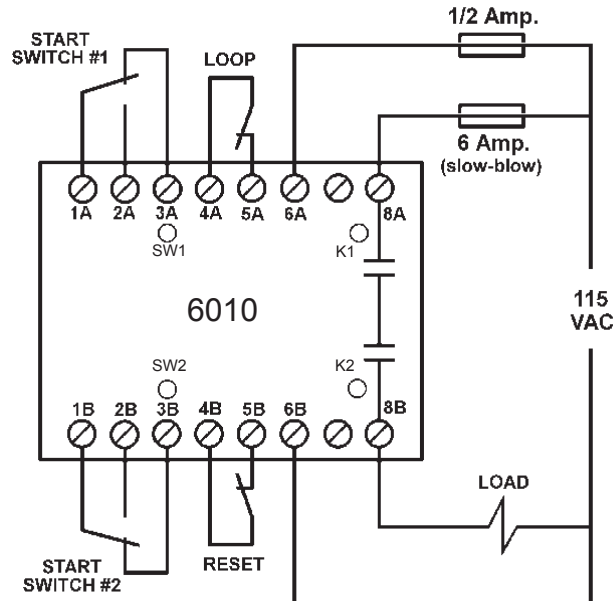

Be sure that electrical power is turned off before attempting to make wiring connections to the control. Make electrical connections according to the wiring diagram above. Use 18 gauge stranded copper wire that can withstand 60/75 degrees C. Tighten the wiring terminals to 1.0Nm. To protect the output contacts, a fuse (6A slow blow or 8A fast blow) should be connected before the output contacts as shown in the wiring diagram.

The 6010 control must operate with additional external components as described below. The selection and connection of these additional components must conform to the relevant safety standard EN 574.

Start switches: The Start switches must be of a dry contact Form-C type. The operating voltage of the control determines the voltage that will be applied to the Start switches. These start switches must be mounted at a distance that prohibits the operator from releasing the switch and reaching into the danger zone. Please refer to EN 999 "Hand Velocity" for more information.

Loop & Reset circuits: The Loop circuit is used to prepare the control to begin a machine cycle, and the Reset circuit can be used to end it. Both circuits require switches of the dry contact type and rated for the supply voltage.

Load circuit: When the load device is inductive, a load suppressor should be used (Nolatron part no: 30165). Operating an inductive load without adequate suppression will greatly reduce the life of the output contacts.

MODEL 6010 OPERATION

To prepare the control for a machine cycle: power is applied, both Start switches are open and the Loop circuit is closed. Indicators SW1/SW2 both light when these conditions are met.

To begin a machine cycle: the Reset circuit must be closed and both Start switches must be pressed simultaneously (within .5 sec.). When these conditions are met, indicators SW1/SW2 will go out, indicators K1/K2 will both light, and the output relays will energize.

To end the machine cycle: The output will open when either or both Start switches are released. The machine cycle can also be ended by momentarily opening the Reset circuit regardless of whether the start switches are still depressed. In some applications the Reset switch is used as a means to provide a "single stroke" of the machine.

Operation when a fault occurs: The control will not energize the output circuit due to an internal fault condition. Should a fault take place, the control should be replaced. For safety reasons, Nolatron does not recommend that anyone attempt to service the control for any reason.

Note: The Loop and Reset switches must be closed before a machine cycle can be started. These switches are optional and are not required for all applications. Do not remove the factory installed jumper wires unless you intend to install these optional switches.



WARNING

These anti-tiedown controls are not intended for use without adequate point of operation safety guards, which must be provided for the operator's protection. The user must see that these controls are properly installed, cared for and operated to meet all applicable local and national requirements. Failure to comply could result in serious bodily injury and/or property damage.

WARRANTY: Nolatron LLC warrants its products against defects in material and workmanship under normal and proper use for a period of one year from date of shipment. Nolatron's obligation under this warranty is limited to furnishing, without charge and at our discretion, either replacement or repair of any defective part. This warranty does not apply under the following conditions: (1) When the product has been operated at other than specified voltage or currents. (2) When the product has sustained contact damage due to improper load transient protection. (3) When the product has been subjected to abuse or has otherwise been tampered with. The foregoing warranty is exclusive and in lieu of all other warranties of quality whether written, oral or implied. Nolatron is not liable for damage or injury which may result from the use of these products.

MODEL 6010 SPECIFICATIONS

European Standards

Utilization	Category AC-15
Intermittent Duty	Class 1200 (max. switching frequency of 1200 cycles/hour)
Radiation Standards	EMV/EMC/CEM EN50081-1, EN 50082-2
Other Standards	EN 60947-5-1
Safety Classification	EN574 category 4, type IIIc
Typical Applications	Eccentric (EN 692) and Hydraulic (EN693) power presses
Minimum Clearance	Mounting IP52, Housing IP40, Terminals IP20
Rated Insulation (Ui)	250VAC (rms)
Max impulse (Uimp)	500 VAC (rms)
Rated operational current (Ie)	.8 Amp
Suitability for isolation	Not suitable

Physical

Size	75mm long, 55mm Wide, 110mm Deep
Weight	400 grams
Mounting	DIN-Rail compatible or mounting holes (use two 3.5mm screws)
Wiring connection	Screw terminals, for 18 gauge stranded wire, Torque to 1.0 Nm
Drop Height	1 meter max.
Housing Material	Polycarbonate, UL94 flame class V-2, NEMA 12 (IEC IP52)
Vibration Resistance	10-55HZ @ .35mm

Environmental

Temperature Range	-10 to +55 C (operating) -25 to +85 C (storage)
Classification	Microenvironmental pollution degree 3
Climate condition	DIN 40040 Class F
Humidity	50% max. @ 40 deg. C., Altitude not to exceed 2000m.

Start Switches

Type required	Dry contact Form-C, w/min. rating of 115 VAC @ 1 amp.
Concurrent time	Both start switches must be pressed within 0.5 sec.
Recovery time	The start switches must be open for at least one second

Optional Switches

Loop circuit	Dry contact Form A, w/min. rating of 115 VAC @ 1 amp.
Reset circuit	Dry contact Form B, w/min. rating of 115 VAC @ 1 amp. (30 millisecond response time)

Operating Power (Ue)

115 VAC (± 15%), 50/60Hz. @ 250ma.
Power consumption less than 5 watts
External protection of unit: 1/2 Amp fuse

Output

Type	2 normally open safety contacts, positive guided
Switching Current (normal)	8 Amps @ 250 VAC (maximum inrush current)
Switching Current (abnormal)	10 Amps @ 250 VAC
Conditional short-circuit rating	10 Amps @ 250 VAC
Switching Overvoltage	500 VAC (rms)
Continuous Current (Ithe)	.8 Amps @ 100% duty cycle (enclosure ≥ 8000 sq. cm.)
Max. Voltage	250 VAC (rms) / 300 VDC
Response time	40ms operate / 50ms release
Protection of Contact	External 6 Amp slow or 8 Amp fast acting fuse (VDE 0600 Pt. 200)
Life	10 million mechanical operations (minimum)