

D2T

Miniature Power/Door Switch

Door Switch Incorporated with Two Circuits for Power Loads and Micro Loads.

- Compact size, with two separate circuits for power and signals.
- Panel- or screw-mounted with ease.

RoHS Compliant

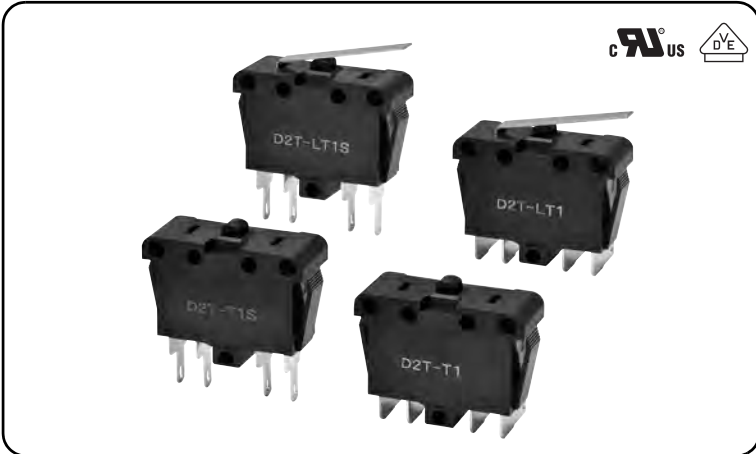

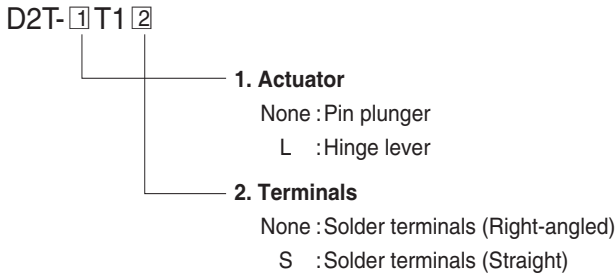

D2T

Model Number Legend



List of Models

Actuator	Terminals	Right-angled	Straight
Pin plunger		D2T-T1	D2T-T1S
Hinge lever		D2T-LT1	D2T-LT1S

Contact Form

- DPST-NO model

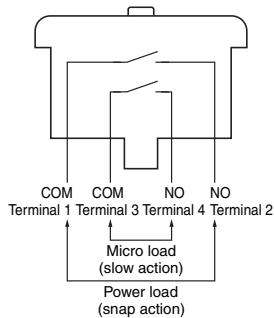

Contact Specifications

Item	Contact	Between terminals 1 and 2	Between terminals 3 and 4
Contact	Specification	Rivet	Plated
	Material	Silver	
	Gap (standard value)	1 mm	1.4 mm
Inrush current		60 A max.	-
Minimum applicable load (reference value)		160 mA at 5 VDC	1 mA at 5 VDC

Ratings

Terminal	Rated voltage	Resistive load
Between terminals 1 and 2	250 VAC	5 A
Between terminals 3 and 4	125 VAC	0.1 A

Note. The above rating values apply under the following test conditions.
 (1) Ambient temperature: 20±2°C
 (2) Ambient humidity: 65±5%
 (3) Operating frequency: 30 operations/min

Approved Safety Standards

UL (UL61058-1)/cUL (CSA G22.2 No.61058-1)

Rated voltage	Terminals 1 and 2	Terminals 3 and 4
125 VAC	5 A	0.1 A
250 VAC	5 A	-

VDE (EN61058-1)

Rated voltage	Terminals 1 and 2	Terminals 3 and 4
125 VAC	-	0.1 A
250 VAC	5 A	-

Testing conditions: 5E4 (50,000 operations) T85 (0°C to 85°C)

Characteristics

Permissible operating speed		10 mm to 500 m/s (for pin plunger models)
Permissible operating frequency	Mechanical	120 operations/min
	Electrical	30 operations/min
Insulation resistance		100 MΩ min. (at 500 VDC with insulation tester)
Contact resistance (initial value)		Between terminals: 1 and 2: 50 mΩ max. Between terminals: 3 and 4: 100 mΩ max.
Dielectric strength	Between terminals of the same polarity	1,000 VAC 50/60 Hz for 1 min
	Between current-carrying metal parts and ground	1,500 VAC 50/60 Hz for 1 min
	Between each terminals and non-current-carrying metal parts	1,500 VAC 50/60 Hz for 1 min
	Between terminals of different polarity	1,500 VAC 50/60 Hz for 1 min
Vibration resistance *1	Malfunction	10 to 55 Hz, 1.5 mm double amplitude
Shock resistance	Destruction	1,000 m/s ² (approx. 100G) max.
	Malfunction *1	300 m/s ² (approx. 30G) max.
Durability *2	Mechanical	100,000 operations min. (60 operations/min)
	Electrical	100,000 operations min. (30 operations/min)
Degree of protection		IEC IP40
Degree of protection against electric shock		Class I
Proof tracking index (PTI)		175
Ambient operating temperature		-25°C to +85°C at ambient humidity of 60% max. (with no icing or condensation)
Ambient operating humidity		85% max. (for +5°C to +35°C)
Weight		Approx. 10g (pin plunger models)

Note. The data given above are initial values.

*1. The values are at Free Position and Total Travel Position values for pin plunger, and Total Travel Position value for lever. Close or open circuit of the contact is 1 ms max.

*2. For testing conditions, consult your OMRON sales representative.

Mounting Holes (Unit: mm)

Screw Mounting Hole Dimensions

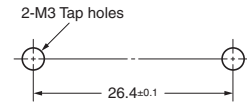

Panel Cutout Dimensions

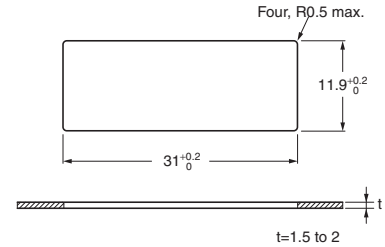

D2T

Dimensions (Unit: mm) and Operating Characteristics

The illustrations and drawings are for right-angled terminals. Straight terminals are omitted.

● Pin Plunger Models

D2T-T1
D2T-T1S

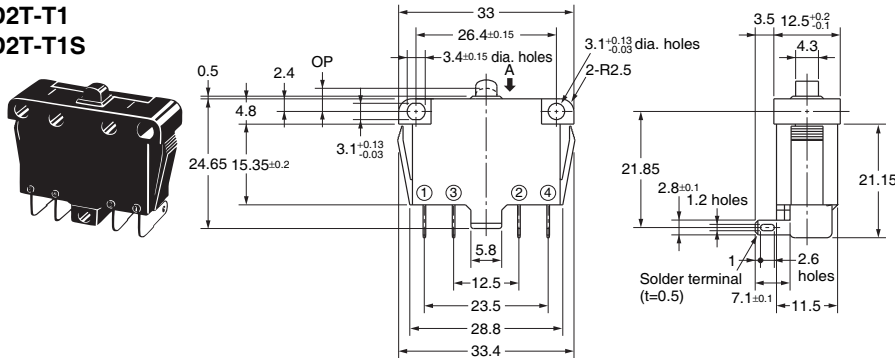

Model		D2T-T1 D2T-T1S
Operating Characteristics		
Operating Force	OF Max.	3.24 N {330 gf}
Releasing Force	RF Min.	0.5 N {50 gf}
Total Travel Force	TTF Max.	6.37 N {650 gf}
Overtravel	OT Min.	0.8 mm
Operating Position	OP *	4.4 ± 0.6 mm*

* Operating sequence of the circuit between terminals 1 and 2 and the circuit between terminals 3 and 4 is not specified.

● Hinge Lever Models

D2T-LT1
D2T-LT1S

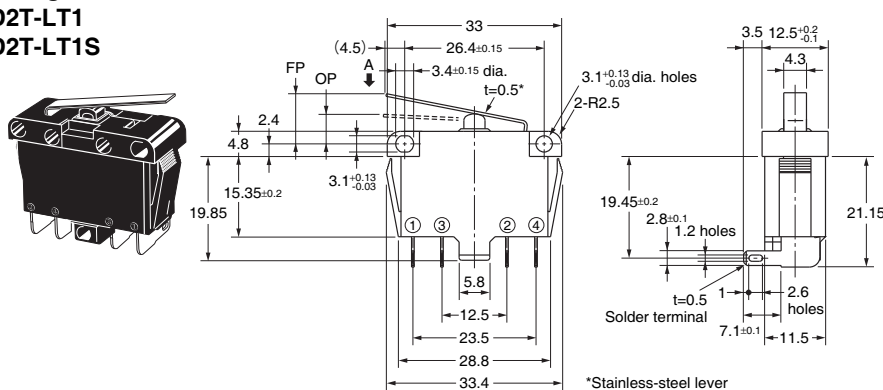

Model		D2T-LT1 D2T-LT1S
Operating Characteristics		
Operating Force	OF Max.	1.47 N {150 gf}
Releasing Force	RF Min.	0.20 N {20 gf}
Total Travel Force	TTF Max.	2.45 N {250 gf}
Overtravel	OT Min.	1.6 mm
Free Position	FP Max.	10.1 mm
Operating Position	OP *	6.9 ± 1.3 mm
Releasing Position	RP Max.	9.5 mm
Total Travel Position	TTP Max.	3.6 mm

* Operating sequence of the circuit between terminals 1 and 2 and the circuit between terminals 3 and 4 is not specified.

Note 1. Unless otherwise specified, a tolerance of ±0.15 mm applies to all dimensions.

Note 2. The operating characteristics are for operation in the A direction (↓)

Precautions

★ Please refer to "Basic Switches Common Precautions" for correct use.

Correct Use

●Mounting

- Apply operation force to the pin plunger in the direction it operates. Applying forces laterally or from an oblique direction may damage the pin plunger.

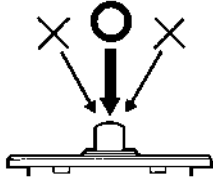

- Use M3 mounting screw with plane washers or spring washers to securely mount the Switch. Tighten the screws to a torque of 0.39 to 0.59 N·m {4 to 6 kgf·cm}.

●Soldering

- Terminal connection

When soldering the lead wire to the terminal, first insert the lead wire conductor through the terminal hole and then conduct soldering.

Complete the soldering at the iron tip temperature not exceeding 350°C within 3 seconds, and do not apply any external force for 1 minute after soldering. Soldering at an excessively high temperature or soldering for more than 3 s may deteriorate the characteristics of the Switch.

Please check each region's Terms & Conditions by region website.

OMRON Corporation

Electronic and Mechanical Components Company

Regional Contact

Americas

<https://www.components.omron.com/>

Asia-Pacific

<https://ecb.omron.com.sg/>

Korea

<https://www.omron-ecb.co.kr/>

Europe

<http://components.omron.eu/>

China

<https://www.ecb.omron.com.cn/>

Japan

<https://www.omron.co.jp/ecb/>