

THESE DRAWINGS ARE THE PROPERTY OF QUALTEK ELECTRONICS AND NOT TO BE REPRODUCED FOR OR COMMUNICATED TO A THIRD PARTY WITHOUT THE EXPRESS WRITTEN PERMISSION OF AN OFFICER OF QUALTEK ELECTRONICS.

REVISION			
REV.	DESCRIPTION	DATE	APPROVED
B	RoHS Compliancy	06-01-06	DP

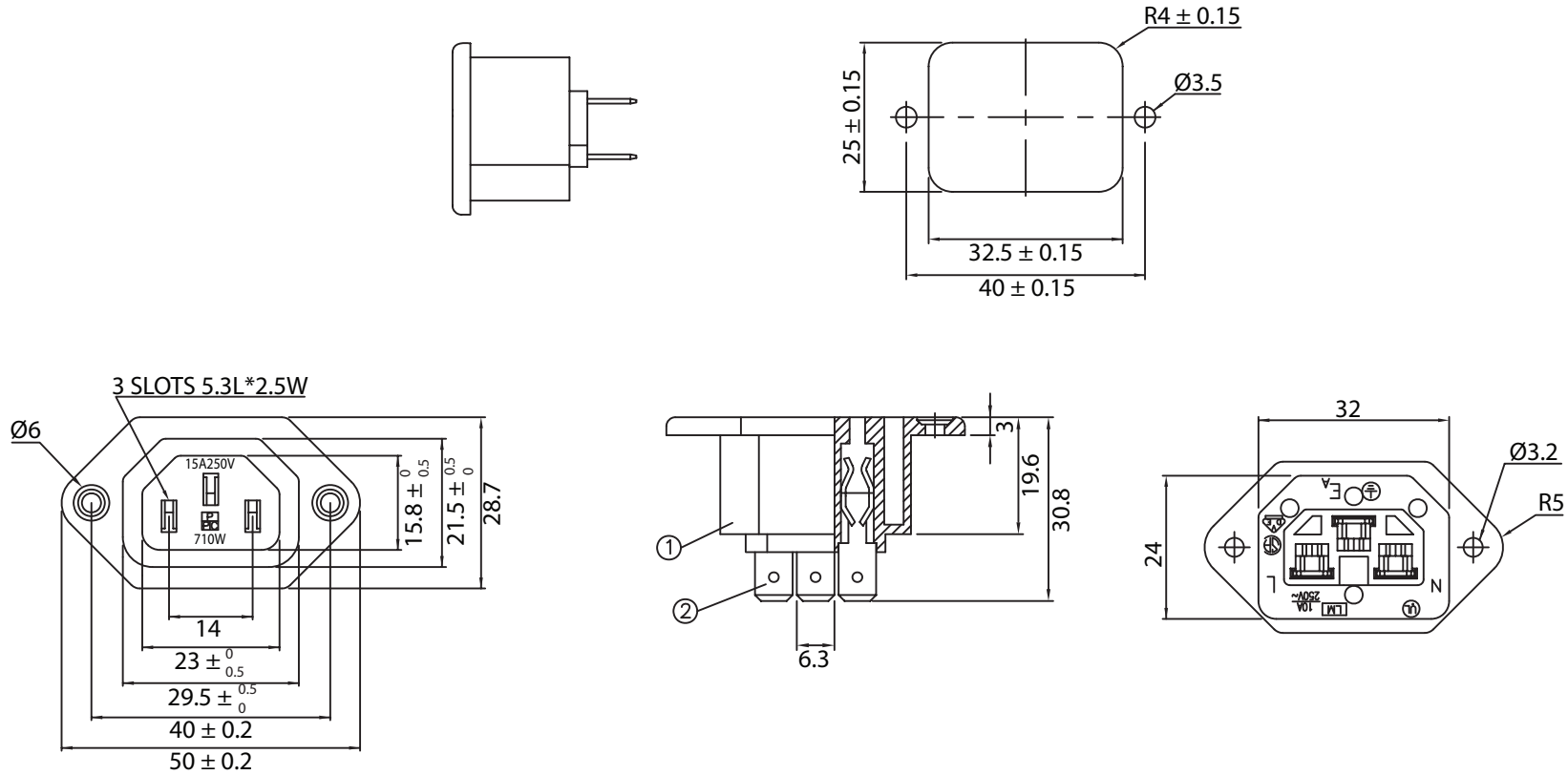

CONTROLLED

NOTES:

MATERIAL:

HOUSING: THERMOPLASTIC
 TERMINAL: COPPER ALLOY

RATING:

UL, CSA: 15A 250V AC
 VDE: 10A 250V AC

INSULATION RESISTANCE: OVER 100 OHM 500V DC

DIELECTRIC STRENGTH: 2000V AC ONE MINUTE

APPROVALS: UL, CSA, VDE

RoHS COMPLIANT

2	Soldering PIN Brass Strip t=0.8mm NI-Plated	3		
1	Body Insulator PBT Black	1		
Qualtek Electronics Corp.				
PPC DIVISION				
Dim range (mm)	Tolerance +/- (mm)	Part Number: 710W-00/03 RoHS Compliant		
0-1	0.15	Description: AC RECEPTACLE		
1-6	0.20			
6-18	0.30			
18-50	0.50			
50-120	0.70			
120-250	0.90	UNIT: mm	REV. B	
250-500	1.20	Drawn / Date	Checked / Date	Approved / Date
		B.ZHANG 03-01-04	03-01-04	JJH / 03-01-04