

Type 70 DC Power Contactors

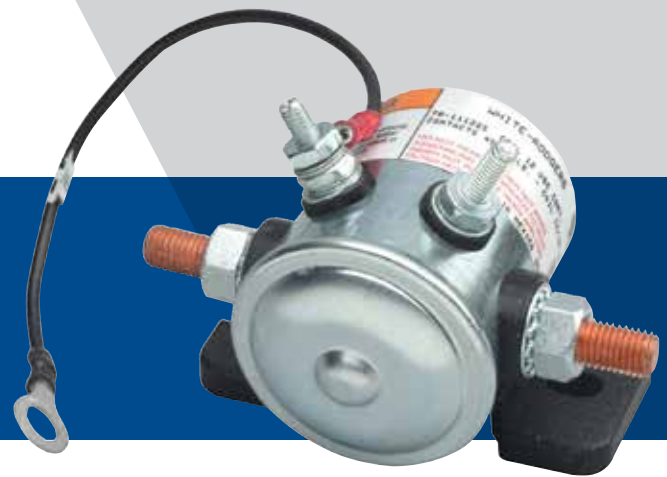

- High current capacity control
- Isolated or grounded coils
- Enclosed in dust-resistant case

SPECIFICATIONS

Dielectric Strength

- 500 volts

Temperature Range

- -40°F/-40°C to 122°F/50°C

Mechanical Life (no load)

- 250,000 operations

Electrical Life (rated load)

- 100,000 cycles

Recommended Mounting Position

- Vertical plane with cap down

Vibration

- 5g's vertical and horizontal planes

Weight (approximate)

- 14.0 oz.

Duty Cycle

- Continuous
- Intermittent: 10 seconds "on" maximum and minimum 60 seconds "off".
One minute "on" maximum and minimum 6 minutes "off"

Hardware Torque Specification

- Mounting Bracket: 100 inch-lbs. max
- Contact Terminal: 45-55 inch-lbs.
(a back-up wrench must be used to hold the bottom nut stationary during installation)
- Coil Terminal: 12-18 inch-lbs

Contacts

- Pole form: SPNO
- Material: copper
- Termination: 5/16- 24 UNF-2A thread

CONTACT RATINGS

Volts DC	Normally open	
	Continuous	Inrush
6	80A	300A
12	80A	150A
24 & 36	50A	50A

Coils

- Voltage: 6 VDC through 36VDC
- Termination: #10-32 UNF-2A thread
- Power (approximate)
Intermittent 23 watts
Continuous 9 watts

Connections

- Two coil terminals isolated from case
- One coil terminal with ground wire, one coil terminal isolated from case
- One coil lead common to NO terminal (stud marked "BAT")

Minimum operating voltage

- 75% of rated coil voltage
- Maximum 10% over rated coil voltage

COIL DATA

Volts DC	Resistance in Ohms	
	Intermittent	Continuous
6	1.5	4.0
12	6.2	16.0
18	16.0	37.4
24	23.9	60.4
36	60.4	114.0

Type 70 DC Power Contactors

APPLICATION NOTES

- Not all part number combinations are available. Please contact your Sales Representative for available part numbers.
- DC contactors applied in battery charging circuits should be protected from higher than rated voltage during charging. The service life may be affected by this condition and the DC contactor may or may not operate the circuit as intended.
- Circuits should be designed to provide safe operation should the DC contactor fail in either the open or closed position.
- Special construction options, including a curved bracket, may be available under other part numbers, including 111-xxxD (short can), 5608-x and 878x-x.
- A back-up wrench **MUST** be used to hold the bottom nut stationary during terminal installation.

ISOLATED COIL

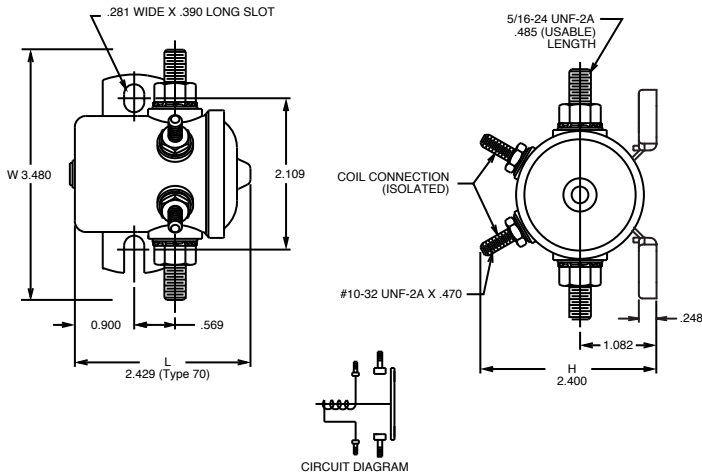

COIL TERMINAL TO GROUND

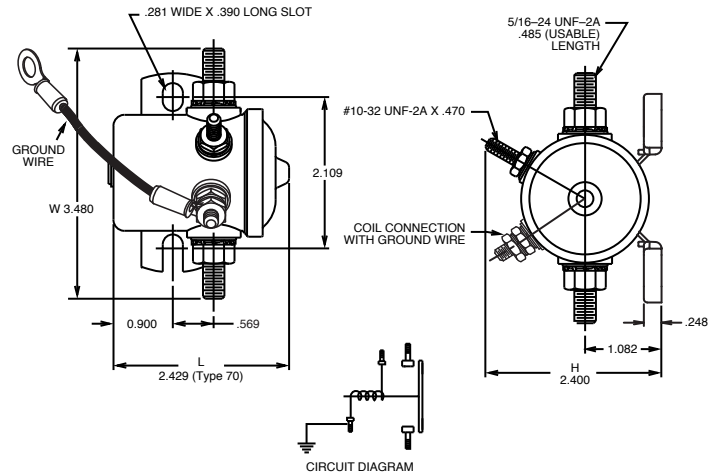

COIL COMMON TO LOAD

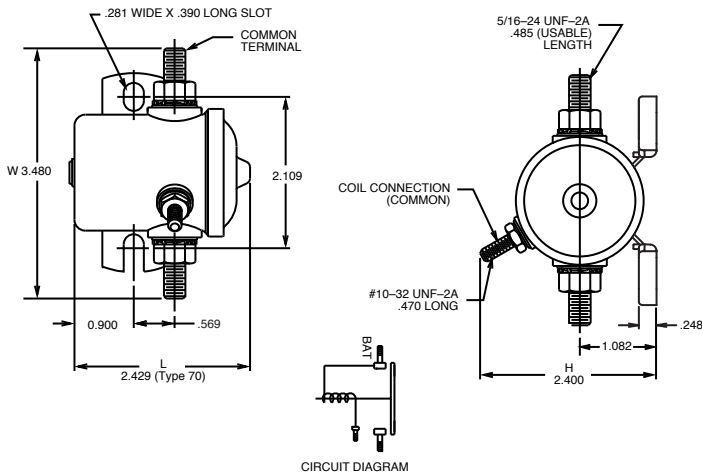

TYPE 70 Part Numbering System

