

# MODEL 2681

## Voltage Band Monitor

- SPDT Output in Standard Relay Configuration
- Monitors Over and Under Voltage
- AC or DC Versions
- Automatic Reset

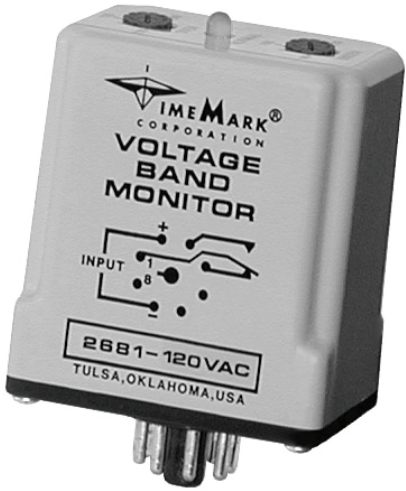

### DESCRIPTION

The Model 2681 Voltage Band Monitor is a dual set-point voltage monitor. Input voltages between the upper and lower set-points will cause the output contacts to pull in (contacts 1 & 3 closed) and the LED indicator to illuminate. Input voltages above or below the set-points will cause the output contacts to drop out (contacts 1 & 4 closed) and extinguish the LED indicator.

The Model 2681 is available in AC or DC versions. AC models of the 2681 are not frequency sensitive and can be used on systems from 50 to 400 Hz. The voltage set-points are screwdriver adjustable over a wide operating range.

The SPDT output configuration is identical to the configuration of general purpose relays. This unit requires a standard 8-pin socket for mounting.

### SPECIFICATIONS

2681 - AC VERSIONS						
Nominal AC voltages	24vac	120vac	208vac	240vac		
Max input voltage	32vac	160vac	250vac	285vac		
Under voltage range	19-24vac	90-120vac	185-208vac	200-240vac		
Over voltage range	24-29vac	120-150vac	208-240vac	240-270vac		
Input frequency (Hz)	50 - 400 Hz					
2681 - DC VERSIONS						
Nominal DC Voltage	12vdc	24vdc	28vdc	48vdc	110vdc	230vdc
Max input voltage	17vdc	32vdc	37vdc	62vdc	145vdc	270vdc
Under voltage range	10-12vdc	19-24vdc	22-28vdc	38-48vdc	85-110vdc	175-230vdc
Over voltage range	12-15vdc	24-29vdc	28-34vdc	48-58vdc	110-135vdc	230-260vdc
2681 - ALL VERSIONS						
Power consumption	± 2 watts max					
Set-point stability	± 0.5% of set-point					
Dead band	2%					
Polarity protection	DC versions only					
Trip response	0.5 sec fixed (± 0.1 sec)					
Reset time	0.1 sec					
Output contacts	SPDT					
Contact rating	10A at 240vac resistive					
Expected relay life	Mechanical: 10 million operations Electrical: 100,000 at rated load					
Operating temp	- 20° to +122°F					
Humidity tolerance	97% w/o condensation					
Mounting	8-pin socket (*order separately)					
Case material	ABS plastic					
Weight	5 oz.					

### DIMENSIONS

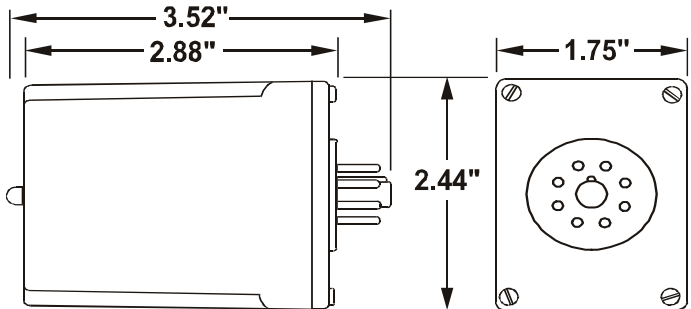

(dimensions have tolerance of ± 0.06)

### PIN DRAWING

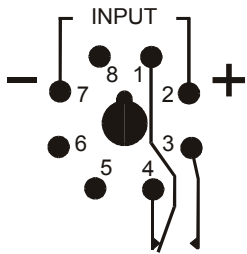

Shown De-Energized

Telephone: Main - (918) 438-1220  
 Sales - (800) 862-2875  
 Fax: (918) 437-7584  
 E-mail: sales@time-mark.com  
 Internet: http://www.time-mark.com



11440 East Pine Street  
 Tulsa, Oklahoma 74116  
 07/2015  
 © 2015 TIME MARK CORPORATION

TIME MARK is a division of  AEMT, Inc.

# MODEL 2681 Voltage Band Monitor

READ ALL INSTRUCTIONS BEFORE INSTALLING, OPERATING OR SERVICING THIS DEVICE.  
KEEP THIS DATA SHEET FOR FUTURE REFERENCE.

## GENERAL SAFETY

POTENTIALLY HAZARDOUS VOLTAGES ARE PRESENT AT THE TERMINALS OF THE MODEL 2681 MONITORS.  
ALL ELECTRICAL POWER SHOULD BE REMOVED WHEN CONNECTING OR DISCONNECTING WIRING.  
THIS DEVICE SHOULD BE INSTALLED AND SERVICED BY QUALIFIED PERSONNEL.

## Installation Instructions

### INSTALLATION

The Model 2681 is a socket-mounted voltage band monitor. The pin configuration diagram on the unit shows the contacts in the power OFF, or tripped condition.

Connect the wiring to the socket as shown in the Typical Application diagram. **Observe the proper polarity of the input voltage for DC models.**

### ADJUSTMENT PROCEDURE

#### NOTE:

When adjusting the Model 2681 you may wish to jumper the control circuit contacts to prevent tripping the load on and off. A variable voltage source and a digital voltmeter provide the most accurate means of calibrating the trip point setting. However, for AC line voltages, you can often obtain a satisfactory calibration by using only the AC line voltage.

1. Set the voltage source at the low level you wish the unit to trip.
2. Slowly rotate the UNDER adjustment until the indicator light just illuminates. Any voltage at or below this level will now trip the relay.
3. Set the voltage source at the high voltage level you wish the unit to trip.
4. Slowly rotate the OVER adjustment until the indicator light just illuminates. Any voltage at or above this level will cause the relay to trip.
5. Apply the nominal operating voltage.

The above calibrations will be correct in most applications. If nuisance tripping occurs, turn the adjustments for a slightly wider voltage band.

A reasonably accurate voltage setting can be obtained by using only the operating line voltage. Apply the voltage and follow steps 2 and 4 above.

Voltages approximately 2% to 4% above and below the nominal voltage will now trip the relay. To prevent nuisance tripping you may need to turn the adjustments slightly lower and higher as needed.

**NOTE:** When installing the Model 2681 monitor in areas of high humidity or contamination, it is recommended that the base area and all exposed metal parts of the socket be coated liberally with a good quality silicon grease, such as Dow Corning DC-4 or DC-4X. Insert the unit into the socket and wipe off excess grease around the base. This will prevent the entrance of moisture and other contaminants into the base and socket areas.

### TYPICAL APPLICATION

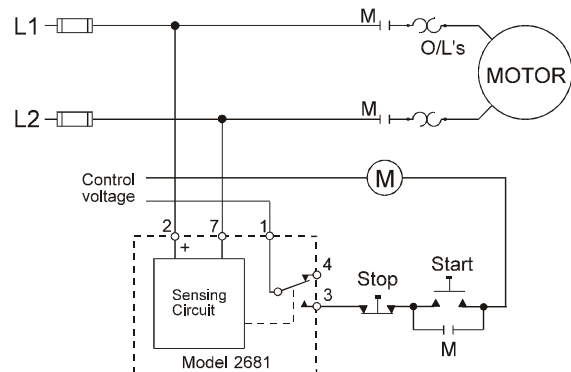

Shows No Power Applied

### TROUBLESHOOTING

Should the Model 2681 fail to operate properly, check that voltage is present and is of the correct level. Check all fuses, and verify that all wiring connections are correct. Should problems persist, contact your local Time Mark Distributor, or the factory at 800-862-2875 (Monday-Friday; 8 a.m. to 5 p.m. CST), for further assistance.

### WARRANTY

The **Model 2681 Voltage Band Monitor** is warranted to be free from defects in materials and workmanship, and is covered by our exclusive **5-year Unconditional Warranty**. If this device fails to operate, for any reason, we will repair or replace it free, for five years from the date of purchase. Contact the Time Mark Sales Department for further details.

Telephone: Main - (918) 438-1220  
Sales - (800) 862-2875  
Fax: (918) 437-7584

E-mail: sales@time-mark.com  
Internet: http://www.time-mark.com



**TIME MARK**  
CORPORATION

11440 East Pine Street  
Tulsa, Oklahoma 74116  
07/2015  
© 2015 TIME MARK CORPORATION

TIME MARK is a division of  AEMT, Inc.