

MODEL 271

3-Stage Alternator

- First on-first off operation
- Alternates triplex systems
- Replaces mechanical alternators

DESCRIPTION

The **Model 271 3-Stage Alternator** is designed to control the motor starters in a stage pumping or compressor system. Its purpose is to ensure that only the required motors are used, and that each motor receives the same average amount of run time. Motors are sequenced in a first on-first off cycle.

Potential uses include water supply systems, air compressor systems, sewage disposal plant systems, storage tank filling or emptying systems, water recycling systems, irrigation systems or sump pump applications.

Operation:

None Closed	All motors off
S3 Closed	C1 or C2 or C3 Running
S3, S2 Closed	C1 & C2, or C2 & C3, or C3 & C1 Running
S3, S2, S1 Closed	C1, C2, C3 Running



SPECIFICATIONS

MODEL	271
Input voltage	120VAC
Power consumption	0.05W
Transient protection	2500V for 10ms
Output configuration	SPST
Contact rating	2 A at 120VAC resistive
Input contacts requirement	1mA at 12VDC
Expected relay life	Mech: 10 million operations Elec: 100,000 operations at rated load
Operating temperature	- 20° to 140° F
Humidity tolerance	0-97% without condensation
Case material	ABS plastic
Weight	1.2 lbs.

DIMENSIONS

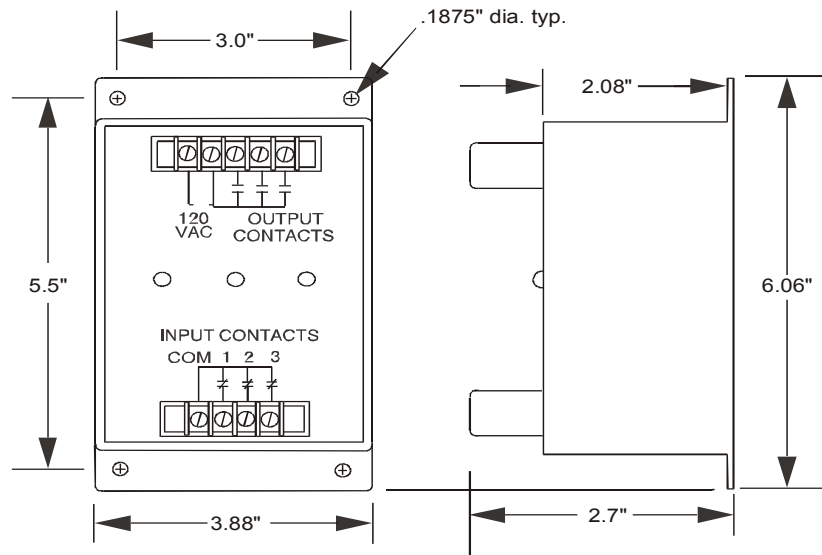

Telephone: Main - (918) 438-1220
Sales - (800) 862-2875
Fax: (918) 437-7584

E-mail: sales@time-mark.com
Internet: http://www.time-mark.com



11440 East Pine Street
Tulsa, Oklahoma 74116

11/2011
© 2011 TIME MARK CORPORATION

TIME MARK is a division of  AEMT, Inc.

MODEL 271

3-Stage Alternator

READ ALL INSTRUCTIONS BEFORE INSTALLING, OPERATING OR SERVICING THIS DEVICE.
KEEP THIS DATA SHEET FOR FUTURE REFERENCE.

GENERAL SAFETY

POTENTIALLY HAZARDOUS VOLTAGES ARE PRESENT AT THE TERMINALS OF THE MODEL 271.
ALL ELECTRICAL POWER SHOULD BE REMOVED WHEN CONNECTING OR DISCONNECTING WIRING.
THIS DEVICE SHOULD BE INSTALLED AND SERVICED BY QUALIFIED PERSONNEL.

Installation Instructions

INSTALLATION

Connect the control wiring to the terminals with the contact markings (refer to the diagram on the unit).

Apply power.

Note: S3 is priority closure.

ADJUSTMENT

No calibration or adjustments needed for this device.

Operation:

None Closed	All motors off
S3 Closed	C1 or C2 or C3 Running
S3, S2 Closed	C1 & C2, or C2 & C3, or C3 & C1 Running
S3, S2, S1 Closed	C1, C2, C3 Running

TROUBLESHOOTING

Should the Model 271 3-Stage Alternator fail to operate, check all connections. Verify that power is present, and check all fuses. Should problems persist, contact your local Distributor, or the Time Mark Sales department at 800-862-2875, Monday thru Friday; 8 a.m. to 5 p.m., CST for further assistance.

WARRANTY

This product is warranted to be free from defects in materials and workmanship for one year. Should this device fail to operate, we will repair it for one year from the date of manufacture. For complete warranty details, see the *Terms and Conditions of Sales* page in the front section of the Time Mark catalog or contact Time Mark at 1-800-862-2875.

TYPICAL APPLICATION

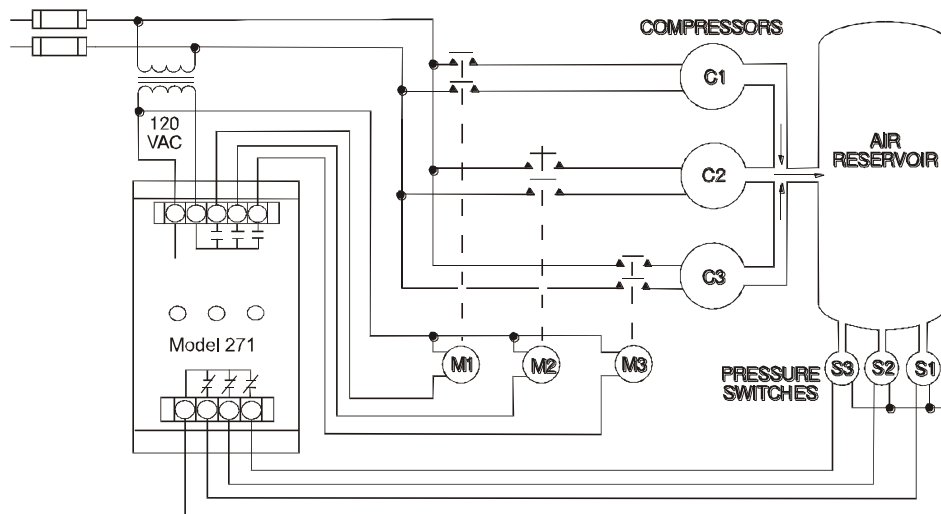

Telephone: Main - (918) 438-1220
Sales - (800) 862-2875
Fax: (918) 437-7584

E-mail: sales@time-mark.com
Internet: http://www.time-mark.com



11440 East Pine Street
Tulsa, Oklahoma 74116

11/2011
© 2011 TIME MARK CORPORATION

TIME MARK is a division of  AEMT, Inc.