

# MODEL 4082



## Liquid Level Controller

- Level simulator control
- 2 scalable 4-20mA outputs
- Output voltage for probe supply
- 8 adjustable setpoints with relay outputs
- LCD level display with zero and span adjustments

### DESCRIPTION

The **Model 4082 Liquid Level Controller** monitors, displays and controls water level up to 34.6 feet, in a tank or reservoir.

The Model 4082 operates from the 4-20mA input signal provided by either the Time Mark **Model 450** or **Model 456-15 Pressure Transducer**. This 4-20mA signal represents the water level to be controlled, where 4mA equals zero feet, and 20mA equals 34.6 feet. A liquid crystal display (LCD) is provided to show the water level during normal operation, and the setpoint values during calibration.

There are eight user-adjustable trip setpoints. As the water level rises above each trip point setting, the front panel LED for that level illuminates, and the corresponding output relay energizes.

Two 4-20mA outputs, which track the 4-20mA input, are also provided. These signal outputs can be re-scaled to different ranges of level by the user. A test control, that simulates an input signal, is available on the front panel. The test control is useful for checking the trip setpoints, and overall system operation.

### DIMENSIONS

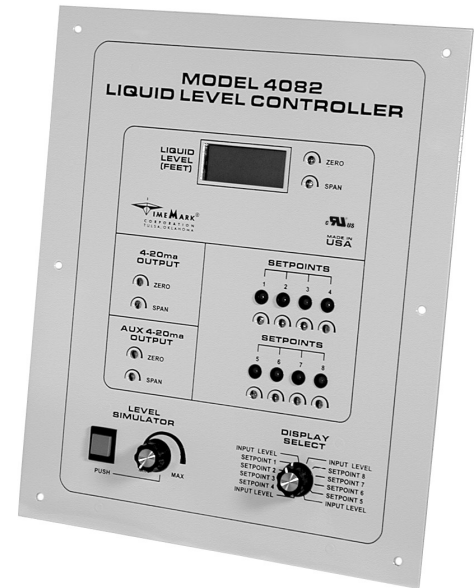
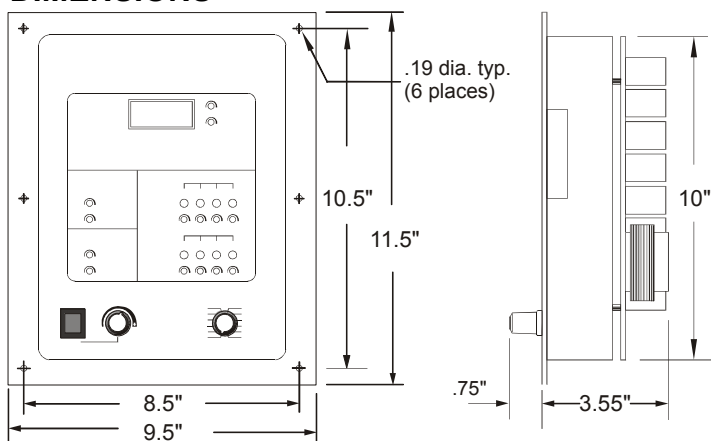

### SPECIFICATIONS

MODEL	4082
Input voltage	120VAC, $\pm 10\%$ 50/60Hz
Power consumption	6W maximum
Signal input	4-20mA (optional 0-5V), 2 or 3 wire
Signal input load	250 $\Omega$ maximum
Dead band	1% of full scale
Repeat accuracy	$\pm 1\%$ of scaled maximum (fixed conditions)
Display type	3-1/2 digit liquid crystal display
Display range	00.0 to 34.6 w/4-20mA input (factory set; user-adjustable)
Display resolution	1 decimal place (factory set; user-adjustable)
Contacts	8 SPDT
Contact rating	10A at 240VAC resistive 4A at 120VAC inductive
Signal output	Output is factory set to track the 4-20mA input. zero and span adjustments are provided: as little as a 2mA change can cause a full swing of the output
Signal output load	300 $\Omega$ maximum
Probe supply voltage	24VDC regulated
Trip levels	8 setpoints, user-adjustable
Operating temperature	+14° to +122° F
Humidity tolerance	0-97% w/o condensation
Enclosure material	front panel - 16 gauge steel rear panel - 20 gauge steel
Termination	removable terminal strips
Weight	5.5 pounds
Agency Approvals	UL Recognized (U.S. & Canadian)

Telephone: Main - (918) 438-1220  
Sales - (800) 862-2875  
Fax: (918) 437-7584

E-mail: sales@time-mark.com  
Internet: http://www.time-mark.com



**TIME MARK**  
CORPORATION

11440 East Pine Street  
Tulsa, Oklahoma 74116

Page 1 of 6 11/2011  
© 2011 TIME MARK CORPORATION

TIME MARK is a division of AEMT, Inc.

# MODEL 4082

# Liquid Level Controller

READ ALL INSTRUCTIONS BEFORE INSTALLING, OPERATING OR SERVICING THIS DEVICE.  
KEEP THIS DATA SHEET FOR FUTURE REFERENCE.

## GENERAL SAFETY

POTENTIALLY HAZARDOUS VOLTAGES ARE PRESENT AT THE TERMINALS OF THE MODEL 4082.  
ALL ELECTRICAL POWER SHOULD BE REMOVED WHEN CONNECTING OR DISCONNECTING WIRING.  
DO NOT EXCEED THE OUTPUT OR INPUT RATINGS, AS STATED IN THE SPECIFICATIONS.  
PROTECT THE UNIT WITH PROPERLY RATED FUSES.  
DO NOT INSTALL IN DAMP OR MOIST AREAS.

THIS DEVICE SHOULD BE INSTALLED AND SERVICED BY QUALIFIED PERSONNEL.

## Installation Instructions

### Front Panel Controls

figure 1

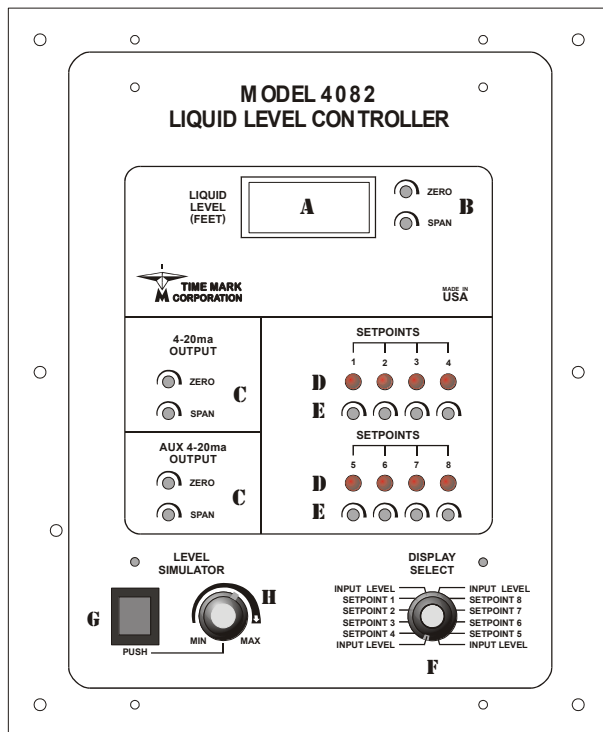

- A 3-1/2 DIGIT LCD INDICATOR - SHOWS LIQUID LEVEL IN FEET
- B ZERO AND SPAN ADJUSTMENTS FOR THE DISPLAY
- C ZERO AND SPAN ADJUSTMENTS FOR 4-20MA OUTPUT SIGNAL
- D INDICATOR LEDs - SHOW WHEN SETPOINT IS REACHED (ONE PER SETPOINT)
- E SETPOINT ADJUSTMENT POTENTIOMETERS
- F DISPLAY SELECT SWITCH - USED TO DISPLAY LIQUID LEVEL OR TRIP POINT SETTINGS
- G PUSH BUTTON - ENABLES SIMULATED LEVEL CHANGE
- H SIMULATES LIQUID LEVEL CHANGE (WITH OR WITHOUT INPUT SIGNAL) WHEN BUTTON G IS PRESSED. THE 4-20MA OUTPUT IS ALSO AFFECTED

### TYPICAL APPLICATION

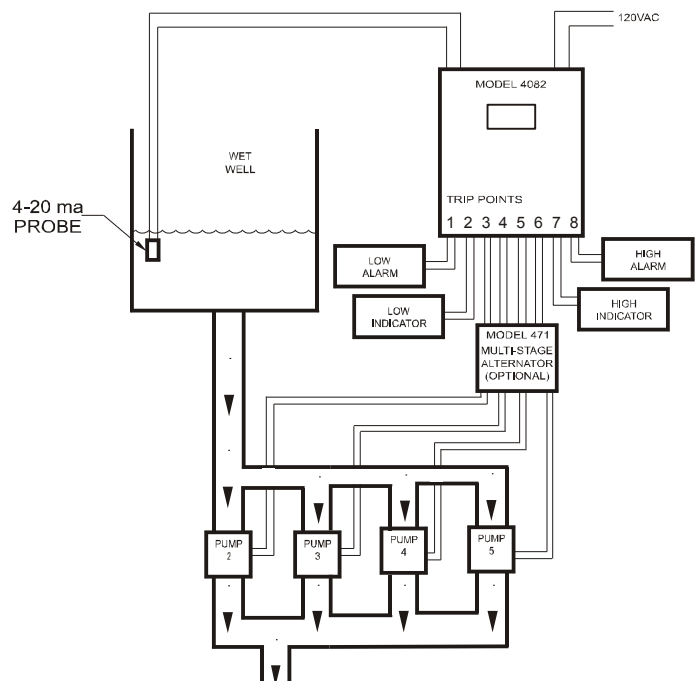

### Warranty

This product is warranted to be free from defects in materials and workmanship for one year. Should this device fail to operate, we will repair it for one year from the date of manufacture. For complete warranty details, see the *Terms and Conditions of Sales* page in the front section of the Time Mark catalog or contact Time Mark at 1-800-862-2875.

Telephone: Main - (918) 438-1220  
Sales - (800) 862-2875  
Fax: (918) 437-7584

E-mail: sales@time-mark.com  
Internet: http://www.time-mark.com



**TIME MARK**  
CORPORATION

11440 East Pine Street  
Tulsa, Oklahoma 74116  
Page 2 of 6 11/2011  
© 2011 TIME MARK CORPORATION

TIME MARK is a division of  AEMT, Inc.

# MODEL 4082

# Liquid Level Controller

figure 2 (rear view of board)

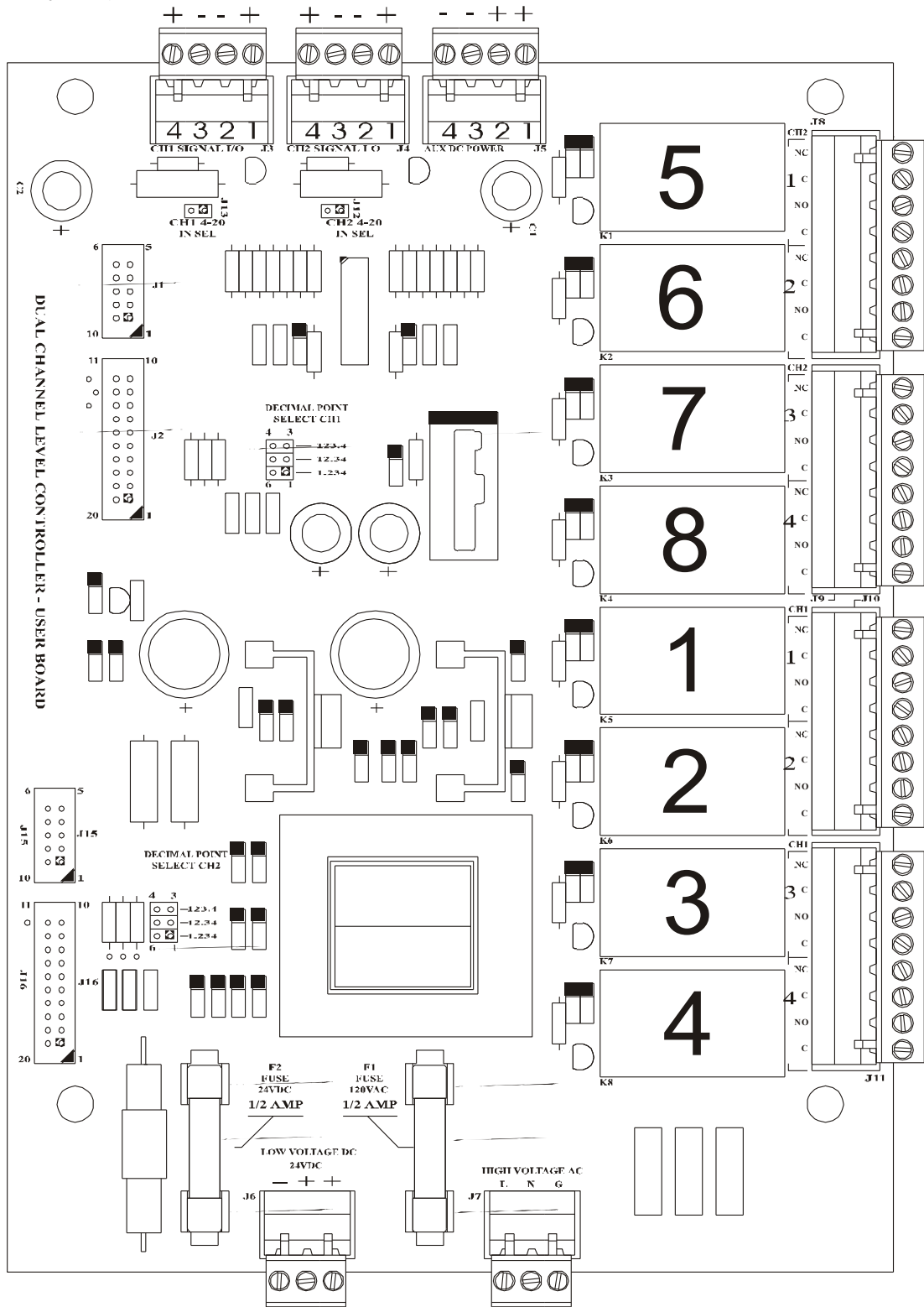

Telephone: Main - (918) 438-1220  
Sales - (800) 862-2875  
Fax: (918) 437-7584

E-mail: sales@time-mark.com  
Internet: http://www.time-mark.com



**TIME MARK**  
CORPORATION

11440 East Pine Street  
Tulsa, Oklahoma 74116

Page 3 of 6 11/2011  
© 2011 TIME MARK CORPORATION

TIME MARK is a division of  AEMT, Inc.

# MODEL 4082 Liquid Level Controller

## Mounting & Wiring

Mount the **Model 4082 Liquid Level Controller** in a suitable enclosure.

Referring to the terminal block decals on the unit, and in *figure 2*, make the following connections:

### OPERATING POWER - Terminal Block J7 (AC POWER IN)

Connect a chassis ground to the terminal marked **G**.

Connect 120VAC operating power to terminals marked **L** (line) and **N** (neutral).

### SIGNAL INPUT - Terminal Block J3

With a **Model 450 Pressure Transducer** or other 3-wire transducer, remotely mounted (*figure 3*), connect the +24VDC OUT terminals (J5) to the voltage input of the Model 450. Connect the 4-20mA IN terminals to the loop terminals of the Model 450. Observe polarity of the connections (“+” to 4-20mA, “—” to GND).

*figure 3*

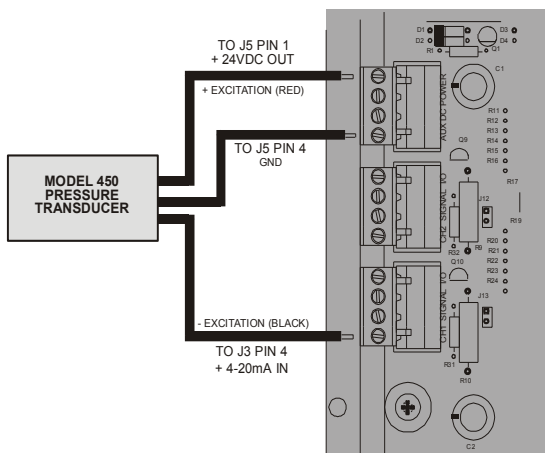

If you use a **Model 456-15 Pressure Transducer** or other 24VDC 2-wire transducer (pressure, ultrasonic, etc.), connect it between the ‘+’ terminal of the +24VDC OUT and the ‘+’ terminal of the 4-20mA IN, see *figure 4*.

### SIGNAL OUTPUT - Terminal Block J3

### AUXILIARY SIGNAL OUTPUT - Terminal Block J4

The 4-20mA OUT terminals may be connected to a remote monitoring loop, a remote display, or for other purposes. Connect these terminals as required for your application. Observe polarity of the connections.

*figure 4*

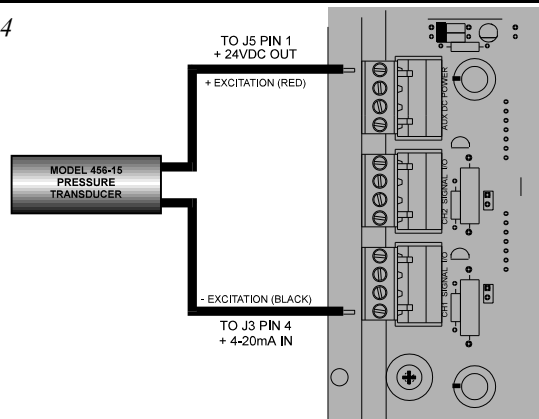

### RELAY OUTPUTS - Terminal Blocks J8, J9, J10 and J11

SPDT contacts are provided for each of the eight setpoints. These relay contacts can be used to control pump motors, alarm circuits, or as inputs to a **Model 403 Liquid Level Controller**. Make wiring connections, as required.

### DISPLAY RESOLUTION - Terminal Blocks J14

The Model 4082 is factory set to display liquid level to one decimal place (i.e., 123.4). This default should be acceptable for most applications.

### Advanced Adjustments

If the application requires, the number of decimal places can be changed to zero, two or three places by moving a jumper (J14), on the pc board of the controller (*figure 5*). For ‘0’ decimal places, remove the jumper (store the jumper connector on a single pin, so it doesn’t get lost).

*figure 5*

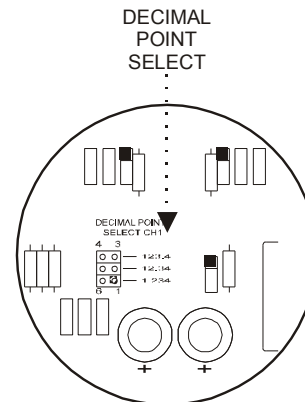

### TRANSDUCER CONNECTION

Connect the 3/16” i.d. tubing to the INPUT air supply fitting on the Model 450 or Model 456 Pressure Transducer. Connect the other end of the tubing to the air compressor, at the tank or well. There should be no connection to the REFERENCE input on the Model 450. Apply operating power to the Model 4082 Controller, and proceed to make the calibration adjustments.

Telephone: Main - (918) 438-1220  
Sales - (800) 862-2875  
Fax: (918) 437-7584

E-mail: sales@time-mark.com  
Internet: http://www.time-mark.com



**TIME MARK**  
CORPORATION

11440 East Pine Street  
Tulsa, Oklahoma 74116

Page 4 of 6 11/2011  
© 2011 TIME MARK CORPORATION

TIME MARK is a division of  **AEMT, Inc.**

## Display ZERO and SPAN Adjustments

For most applications, these controls do not need to be adjusted. The Model 4082 will display any range from 00.0 to 34.6 feet of depth, and is factory set for this range (i.e., 4mA equals 00.0 feet, and 20mA equals 34.6 feet). For levels less than 34.6 feet, the display will still show the correct level.

### Advanced Adjustments

*If your Model 4082 Controller application does not require any adjustments to the factory setting described above, skip this section and go on to the 4-20mA Output Zero & Span Adjustments section.*

If it is necessary to make adjustments, for other transducers, or for liquids other than water, the Model 4082 Controller has a wide display range (-600 to 1999).

If you are monitoring a 20 foot level, the Model 4082 will show 20.0 feet, with an input of approximately 12mA. With a different transducer, however, it will be necessary to re-calibrate the display to accurately show the correct depth. If care is taken, accuracy of 1% or better is possible. An accurate 4-20mA source is required.

Before going on with the adjustment procedures, several critical areas must be thoroughly understood. At this point in the instructions, decimal points will be ignored (*until you know the possible resolution, you won't know where to set the decimal selector*).

First, the largest number possible on the LCD display is 1999 (the left most digit will only show a "1" or a blank).

Second, the difference between the minimum and maximum values to be displayed is the **span**. The Model 4082 Controller has a span range of 250 to 2600 **counts**. The difference between your minimum and maximum values must fall within this range; i.e. your application's span must be at least 250 count, but not over 2600 counts. Once you have this information, you can determine how many decimal places to select. The following are some examples:

1. You use a transducer with a 20mA output equaling 15 feet of liquid. The difference between 0 and 15, is 15 counts, well below the minimum of 250 counts. Add a zero to each number; now the span is 150 counts, still below the minimum. Add another zero, and you now have a span of 1500 counts, well within the span range. Now, you can see that the decimal must be set for two places, for a resolution of 1/100th of a foot, or 15.00.

2. You use a transducer with a 20mA output equaling 25 feet. The span is only 25, so a zero is added to the count. The span is now 250, which meets the minimum span. Select one decimal place (25.0). Notice that adding another zero gives you a count of 2500, which also falls within the span range; however, you cannot place the decimal at two places (25.00) because the LCD display can only show up to 1999 (19.99).
3. You use a transducer with a 20mA output equaling 20 feet. The span is 20, so you must add a zero. A span of 200 still does not meet the minimum of 250, so add another zero for a span of 2000. This falls within the acceptable span range; however, as stated above, the maximum LCD display is 1999. Therefore, the decimal selector must be set to two places, or 19.99. This means that your display will be short of 20 feet by 1/100th of a foot, which should be sufficient in most any application.

Now let's look at the actual adjustment procedure.

The DISPLAY ZERO control sets the lowest number you want the LCD display to read. This number will be displayed when the transducer input is at 4mA. While usually zero (*the factory default*), this number can be as low as -600, or as high as 1749.

The DISPLAY SPAN control sets the highest number you want the display to read. This number will be displayed when the transducer input is 20mA. This number is factory set to 34.6, but can be set as high as 1999, or as low as -350 (*assuming a one decimal place display setting*).

Application example: Display level in a 5 foot tank, when 4mA equal 0 feet, and 20mA equals 5 feet.

1. Using methods previously described in this section, the span is determined to be 500. Set the decimal selector to two places, for a resolution of 5.00.
2. Set the DISPLAY SELECT knob to LIQUID LEVEL (either position).
3. Apply a 4mA signal to the input. Adjust the DISPLAY ZERO control for a 0.00 reading.
4. Apply a 20mA signal to the input. Adjust the DISPLAY SPAN control for a 5.00 reading.
5. Repeat steps 3 and 4 as needed to fine-adjust the display reading. It may be necessary to repeat the steps several times to achieve maximum accuracy.

Telephone: Main - (918) 438-1220  
Sales - (800) 862-2875  
Fax: (918) 437-7584

E-mail: sales@time-mark.com  
Internet: http://www.time-mark.com



**TIME MARK**  
CORPORATION

11440 East Pine Street  
Tulsa, Oklahoma 74116

Page 5 of 6 11/2011  
© 2011 TIME MARK CORPORATION

TIME MARK is a division of  AEMT, Inc.



# MODEL 4082

# Liquid Level Controller

## 4-20ma ZERO & SPAN Adjustments

The 4-20mA output is proportional to, and independent from, the input signal. This allows for very accurate remote monitoring of level changes. The factory default is for the output to track the input; that is, a 4mA signal represents 00.0 feet, and a 20mA signal represents 34.6 feet. However, the output can be zeroed and spanned to a specific range, not necessarily the same as the reading on the LCD display (see *Advanced Adjustments*).

### Advanced Adjustments

If your Model 4082 Controller application does not require any adjustments to the factory settings described above, skip this section and go on to the *Setpoint Adjustments* section.

The 4-20mA output can be zeroed and spanned to a specific range, not necessarily the same as the reading on the LCD display. As an example; with the default input setting (00.0 to 34.6), a 2mA input variation can be expanded to a full 20mA output variation. The maximum allowable output current is 30mA. An accurate 4-20mA source, and a multimeter (digital for highest accuracy), are required to adjust this setting.

**CAUTION: The output can go HIGHER THAN 30mA, but doing so WILL DAMAGE THE CONTROLLER. Care must be taken to limit the output to the 30mA maximum.**

To make adjustments to the default ZERO and SPAN output:

1. Connect the multimeter to the "+" and "-" 4-20mA output terminals. Set the multimeter to read DC current.
2. Apply a 4mA current to the transducer input terminals, and adjust the 4-20mA output ZERO CONTROL until the desired minimum output current is shown on the multimeter.
3. Change the 4mA input current to 20mA, and adjust the 4-20mA SPAN CONTROL until the desired maximum output current is displayed on the multimeter.

**NOTE:** If the maximum current is within the 0-30mA range, but cannot be reached, the 4-20mA SPAN CONTROL is probably out of range. If this is the case, adjust the current as close as possible, and move on to the next step.

4. Repeat steps 2 and 3 until adjustment is no longer necessary.

**NOTE:** It will typically take four to six passes through steps 2 and 3 to complete adjustment. Each pass will get you closer to the final output current.

## SETPOINT Adjustments

The eight setpoints are independently set using adjustment pots (E on figure 1) on the front panel of the Model 4082 Controller. Adjustment results are shown on the LCD display.

In operation, as the liquid level reaches a setpoint, the corresponding LED indicator will illuminate, and its relay will energize. The setpoints match the display range; i.e., if the display is changed to read to two decimal places, the setpoint will also be displayed to two decimal places.

1. To adjust the first setpoint, turn the DISPLAY SELECT knob (F on figure 1) to SETPOINT 1, and adjust the pot for the desired setting, by watching the LCD display.
2. Repeat step 1 for each of the seven additional setpoints.
3. Set the DISPLAY SELECT knob to either LIQUID LEVEL position. The Model 4082 Controller is now ready for operation.

## LEVEL SIMULATOR

For testing purposes, a push button (G on figure 1), and the MIN-MAX adjustment knob (H on figure 1) are provided.

With no input signal applied, set the adjustment to MIN, then press and hold the push button. As the adjustment is turned clockwise (to MAX), the LCD display will show an increasing (*simulated*) liquid level.

As each setpoint is reached, the appropriate LED indicator (D on figure 1) will illuminate and the output should activate; i.e., pump will come on, output relay will energize, or alarm will sound. Releasing the push button returns the Model 4082 Controller to its active mode.

**NOTE:** The LEVEL SIMULATOR adjustment has a range greater than 4-20mA, which can result in a negative reading at the MIN setting.

## Troubleshooting

These units are not field repairable. **Should the Model 4082 not operate properly during the adjustment or testing procedures**, insure that all electrical and air pressure connections are correct. Verify that the proper supply voltage is applied, and check all fuses. Negative display readings may indicate that the 4-20mA input signal is missing or is less than the 4mA minimum. If everything is correct, and the device still fails to operate, contact the factory at **800-862-2875 (Mon-Fri; 8 a.m. to 5 p.m. CST)**. **Should a device fail during use**, contact the factory at **800-862-2875 (Mon-Fri; 8 a.m. to 5 p.m. CST)**, for instructions on returning it for repair.

Telephone: Main - (918) 438-1220  
Sales - (800) 862-2875  
Fax: (918) 437-7584

E-mail: sales@time-mark.com  
Internet: http://www.time-mark.com



**TIME MARK**  
CORPORATION

11440 East Pine Street  
Tulsa, Oklahoma 74116  
Page 6 of 6 11/2011  
© 2011 TIME MARK CORPORATION

TIME MARK is a division of  AEMT, Inc.