

APPROVED: _____
 DATE: _____ TITLE: _____

Rev	AWO #	Description	Date	Appr
-		RELEASED	11/16/18	

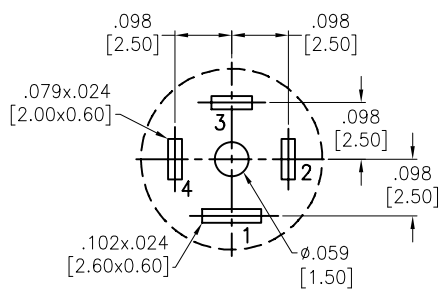

RECOMMENDED PCB LAYOUT
(COPPER SIDE VIEW)

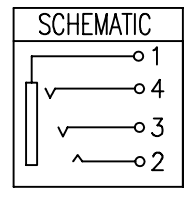
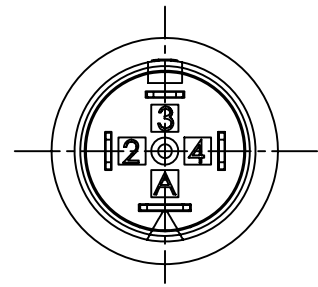
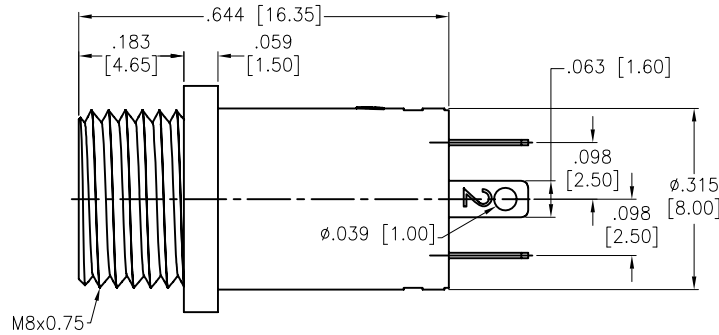
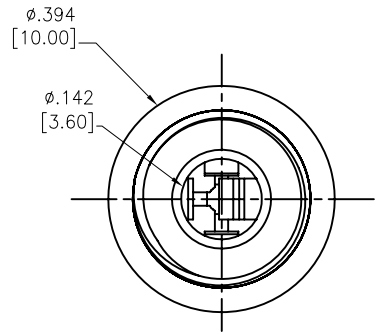
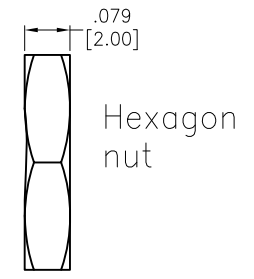
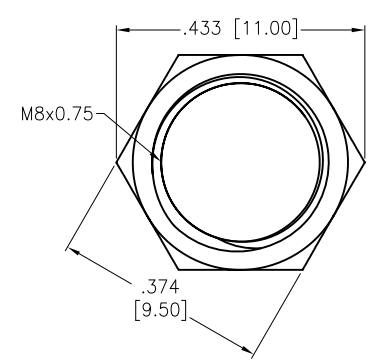
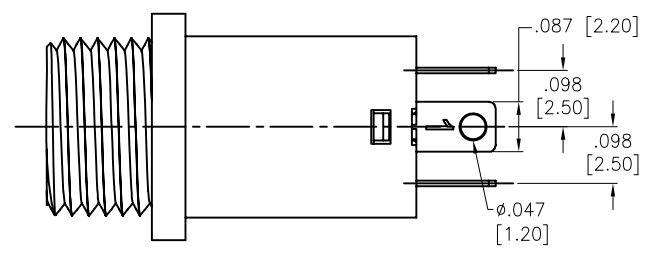

Hexagon nut

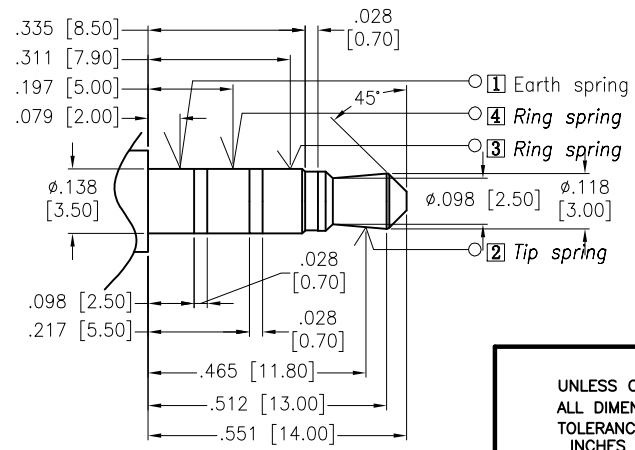

MATE PLUG

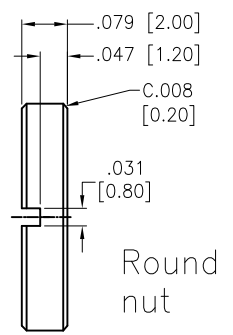
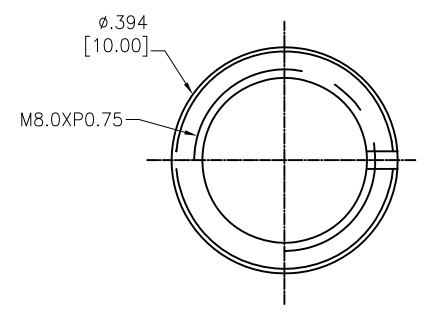

Round nut

ADAM P/N	NUT TYPE
ASJ-165-M-G-HDW-1	Hexagon
ASJ-165-M-G-HDW-2	Round

SPECIFICATIONS:
 Material:
 Insulator: PA66, rated UL 94V-0
 Insulator color: Black
 Contact: Phosphor Bronze
 Nut: Brass, Nickel plated
 Plating:
 Gold flash over Nickel underplate overall
 Electrical:
 Rating: 30 VDC, 0.5 A
 Contact resistance: 30 mohms max
 Insulation resistance: 100 Mohms min @ 500 VDC
 Dielectric withstanding voltage: 500 VAC
 Temperature Rating:
 Operating temperature: -20°C to +70°C
 Environmental:
 Lead free, RoHS compliant.



UNLESS OTHERWISE SPECIFIED
 ALL DIMENSIONS ARE INCHES [MM]
 TOLERANCES: EXCEPT AS NOTED
 INCHES HOLES

.X ± .10	Ø.X ± .10
.XX ± .020	Ø.XX ± .015
.XXX ± .015	Ø.XXX ± .010

ADAM TECH
 INTERCONNECTS
 909 Rahway Avenue,
 Union, NJ 07083
 Phone: 908-687-5000
 Fax: 908-687-5710

APPROVALS		DATE
DRAWN	HR	11/16/18
CHECKED	AC1	11/16/18
APPROVED		

TITLE 3.5MM PHONE JACK, GOLD PLATED		
SIZE X	PART NO. ASJ-165-M-G-HDW-X	REV. -
REF: S00002C	SCALE: NTS	SHEET 1 OF 1