

YA-Frame - Miniature Circuit Breakers



1 Pole
DIN mount



1 Pole
DIN mount



2 Pole
DIN mount



4 Pole
DIN mount

Product Category

- **POLARISED PRODUCT**
300 Vdc, 1 Pole & 2 Pole
400 Vdc, 4 Pole (2 Pole in series + 2 Pole in series)
600 Vdc, 2 Pole in series
- **UNPOLARISED PRODUCT**
150 Vdc, 1 Pole & 2 Pole

Features

- High energy DC circuit breaker
- Ultra compact - 13 mm wide module
- Hydraulic-magnetic technology
- Can be switched on immediately after tripping
- DIN mount, 45 mm front escutcheon (Grey)
- DIN mount, 57 mm front escutcheon (Black)
- Dual mount, 57 mm front escutcheon (Black)
- ON and OFF indication
- Suitable for electrical isolation
- 100% rating capability, independent of ambient temperature
- RoHS compliant
- Box type main terminals

Applications

- Telecom / datacom
- DC circuit protection
- UPS equipment
- Alternative energy equipment
- Battery protection

Auxiliary Switch and Trip Alarm Features

- Auxiliary switch
- AC and DC voltages
- IEC 60947-5-1 (6 A 250 Vac, 0.5 A 110 Vdc)
- GB 14048.5 approved
- Factory fitted
- Attached to right hand side of circuit breaker
- Compact 6.5 mm width



Hydraulic-Magnetic Circuit Breakers 100% rated, unaffected by ambient temperature

YA-FRAME-DAT
REV. E
JUNE 2022

2206022

Data Sheet
Page 1 of 12

YA-Frame - Miniature Circuit Breakers

Technical Data: Approvals

Product Type	Circuit Breaker YA, Polarised Product		
Approvals	IEC 60947-2, GB14048.2, CE, UKCA, AS/NZS 60947-2		
Number of Poles	1 Pole	2 Pole	4 (2 pole in series + 2 pole in series)
Operating Voltages & Interrupting Capacity	300 Vdc @ 6 kA	300 Vdc @ 6 kA 600 Vdc @ 6 kA (Series)	400 Vdc @ 6 kA
Minimum Current Rating	0.5 A	0.5 A	0.5 A
Maximum Current Rating	50 A	50 A	32 A

Product Type	Circuit Breaker YA, Polarised Product		
Approvals	UL 489A		
Number of Poles	1 & 2 Poles	2 Pole in series	4 (2 Pole in series + 2 Pole in series)
Operating Voltages & Interrupting Capacity	300 Vdc @ 10 kA	600 Vdc @ 10 kA	400 Vdc @ 10 kA
Minimum Current Rating	0.5 A	0.5 A	0.5 A
Maximum Current Rating	50 A	50 A	32 A

Product Type	Circuit Breaker YA, Unpolarised Product	
Approvals	IEC 60947-2, GB14048.2, CE, UKCA, AS/NZS 60947-2	
Number of Poles	1 Pole	2 Pole
Operating Voltages & Interrupting Capacity	150 Vdc @ 6 kA	150 Vdc @ 6 kA
Minimum Current Rating	0.5 A	0.5 A
Maximum Current Rating	50 A	50 A

Verify approvals for specific ratings in accordance with the relevant test certificates.

Product Type	Circuit Breaker YA
Ambient Operating Temperature	-40 °C to +85 °C
Mounting Options	Dual (DIN and CBI Mini rail)
Time Delay Curves	Various
Endurance	10000 operations; 1500 with current, 8500 without current (IEC 60947-2 Clause 7.2.4.2)* Minimum of 1000 operations with current (UL 489A Clause 12)*
Dielectric Strength	1000 - 2000 Vac for one minute (IEC 60947-2 Clause 8.3.3.3)* 1000 Vac plus twice the rated voltage for one minute (UL 489A Clause 8)*
Rated Impulse Withstand Voltage	4 kV (IEC 60947-2 Clause 8.3.3.2)*
Weight	110 g per pole
Altitude	Certification tests conducted at altitude ≈ 2000 metres. Will operate at higher altitudes.
Shock	20 G (IEC 60068-2-27)
Vibration	3 G (IEC 60068-2-6) (sinusoidal wave)
Flammability	I3 - Ignition does not persist at 850°C after glow wire is withdrawn with an oxygen index of ≥ 28
Toxicity	F1 - Smoke index of ≤ 20 which determines the fume class
Pollution Degree	PD2 - Normally only non-conductive pollution occurs. Temporary conductivity caused by condensation is to be expected.

* Refer to the standard for details

Circuit Breaker	Wire Size (IEC)	Wire Gauge (UL)	Torque (IEC)	Torque (UL)	Comments
Main Terminals	2.5 mm ² to 16 mm ²	14 – 6 AWG	3.5 Nm	30 in-lb	Pozidriv #2 Combi head

YA-Frame - Miniature Circuit Breakers

Long Code

Example Code: YAD- - 1 -(13)-M-50A- B03 - - - -

Group	1	2	3	4	5	6	7	8	9	10
Requirement	YAD frame	Auxiliary	Number of poles	Module width	Time delay curve	Current rating	Polarity marking, voltage & construction	Shunt trip	Termination	Customer Specific
Long Code	YAD	-	1	(13)	M	50A	B03	-	-	-

Ordering Information

Group	Code	Description	Comments
Group 1: Frame Type	YAD	YA - Frame (13 mm circuit breaker DIN mounting 57 mm front escutcheon)	Black shell
	YAK	YA - Frame (13 mm circuit breaker Dual mounting 57 mm front escutcheon)	Black shell
	YAM	YA - Frame (13 mm circuit breaker DIN mounting 45 mm front escutcheon)	Grey shell
Group 2: Auxiliary			
	-	Not applicable	
	A	Auxiliary switch	
	T	Trip alarm	
	AT	Auxiliary switch & Trip alarm	
Group 3: Number of poles			
	1	One pole	
	2	Two pole	
	4	Four pole	
Group 4: Module Width			
	(13)	13 mm module	
Group 5: Time Delay			
	I	Instantaneous delay	
	S	Short delay	
	M	Medium delay	
	L	Long delay	
Group 6: Current Rating			
		0.5, 1, 2, 3, 5, 6, 10, 15, 16, 20, 25, 30, 32, 35, 40, 45, 50 A	
Group 7: Polarity Marking, Voltage & Construction			
	150	150 Vdc Unpolarised	
	B03	300 Vdc Polarised, Positive Bottom	
	BT3	300 Vdc Polarised, (1 + 1 = 2p) - Positive Bottom / Positive Top	
	BT6	600 Vdc Polarised, Series Connection, (2p) - Positive Bottom / Positive Top	
	BU4	400 Vdc Polarised, Series Connection, (2 + 2 = 4p) - Connection @ Bottom (Bottom Positive, Bottom Negative / Bottom Negative, Bottom Positive)	

Continues on page 4

YA-Frame - Miniature Circuit Breakers

Ordering Information continues

Group 8: Shunt Trip	Code	Description	Comments
	-	Not applicable	if shunt trip is not required
	C	12 Vdc Shunt trip (Box terminal)	<p>Recommended pulse tolerance 100 ms - 60 s</p> <p>Note: Shunt trip option carries no approvals - available as a special order only</p>
	D	24 Vdc Shunt trip (Box terminal)	
	E	48 Vdc Shunt trip (Box terminal)	
	G	110 Vdc or 110 Vac Shunt trip (Box terminal)	
	H	220 / 240 Vac Shunt trip (Box terminal)	
Group 9: Termination	Code	Description	Comments
	-	Not applicable	No busbar supplied - if applicable the busbar / Cable is to be provided & fitted by the customer
	S	Factory fitted busbar - incoming circuit CONNECTION @ BOTTOM	
	U	Busbar to be supplied loose in a KIT FORM & to be field fitted by customer	
	T	Factory fitted Busbar - incoming circuit CONNECTION @ TOP	BUSBAR to be fitted @ the BOTTOM
Group 10: Customer Specific	Code	Description	Comments
	-	Not applicable	

For options not listed, please contact CBI for assistance

YA-Frame - Miniature Circuit Breakers

Time Delay Curve

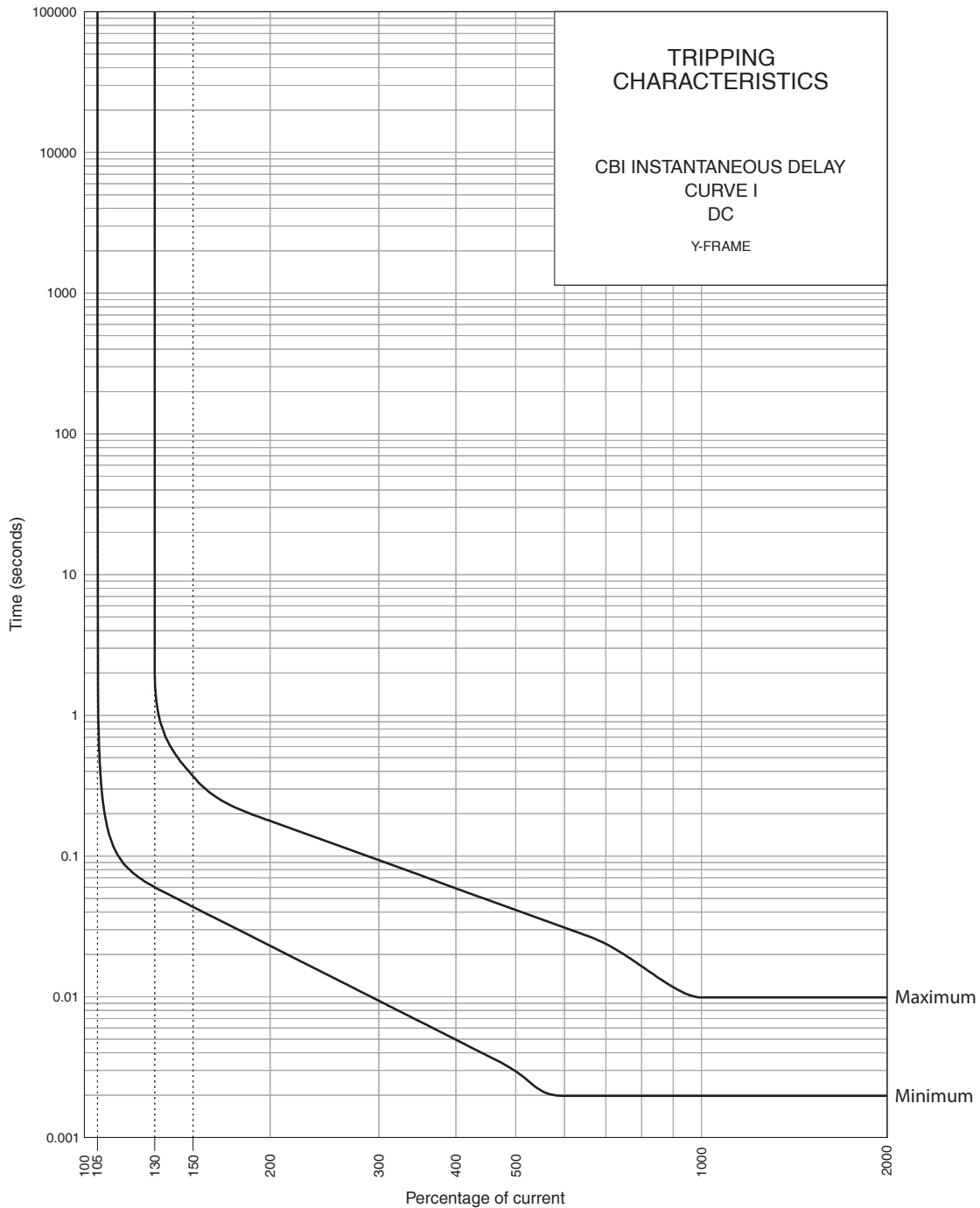

3990A961 REV. A

PERCENTAGE OF RATED CURRENT	105%	130%	150%	200%	300%	400%	500%	600%	700%	800%	900%	1000%	1200%
MINIMUM TRIP TIME IN SECONDS	NO TRIP	0.06	0.04	0.02	0.009	0.005	0.003	0.002	0.002	0.002	0.002	0.002	0.002
MAXIMUM TRIP TIME IN SECONDS	NO TRIP	2	0.4	0.2	0.09	0.1	0.04	0.03	0.02	0.016	0.012	0.01	0.01

YA-Frame - Miniature Circuit Breakers

Time Delay Curve

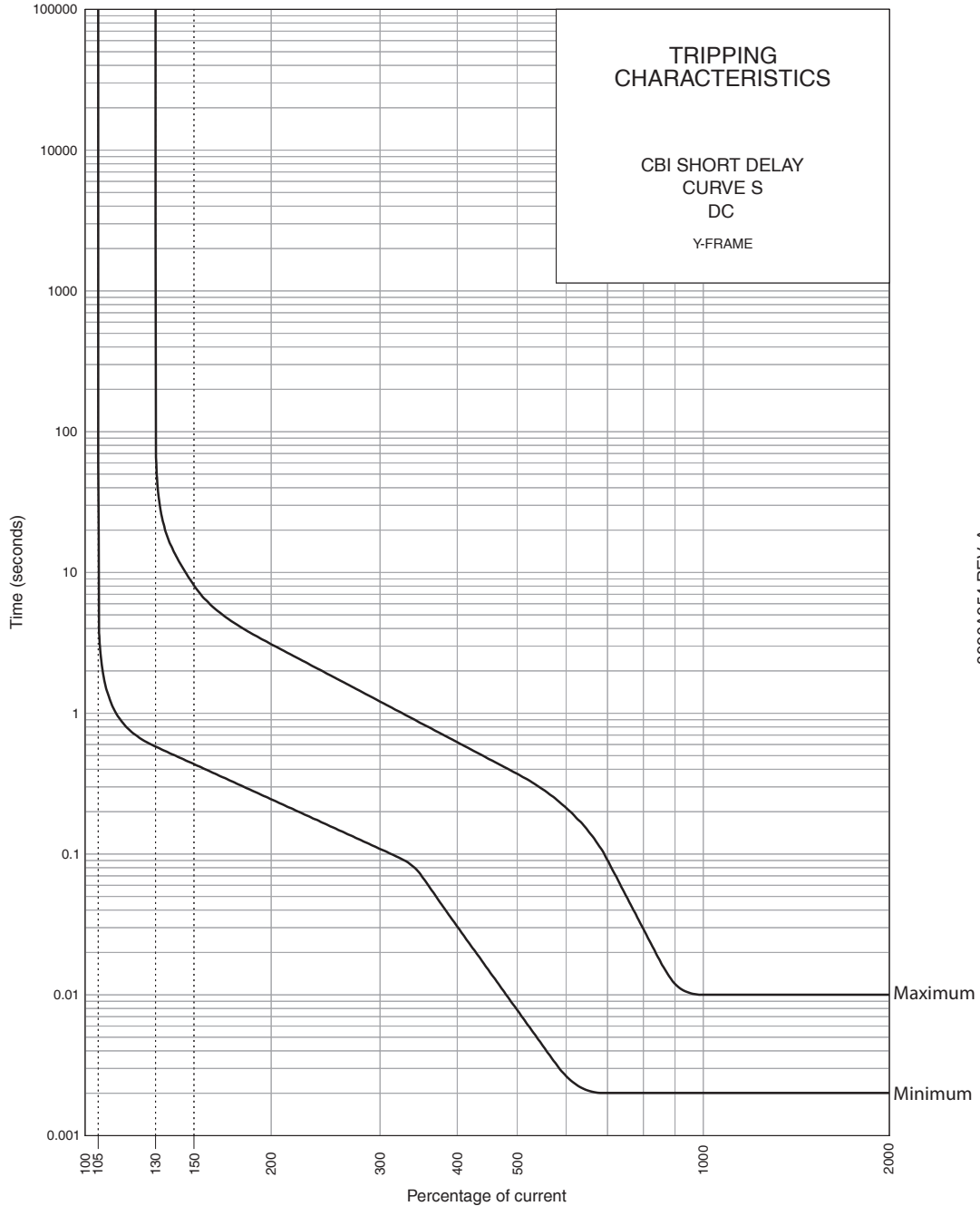

3990A954 REV. A

PERCENTAGE OF RATED CURRENT	105%	130%	150%	200%	300%	400%	500%	600%	700%	800%	900%	1000%	1200%
MINIMUM TRIP TIME IN SECONDS	NO TRIP	0.58	0.44	0.2	0.1	0.03	0.01	0.003	0.002	0.002	0.002	0.002	0.002
MAXIMUM TRIP TIME IN SECONDS	NO TRIP	3000	8.1	3.1	1.21	0.6	0.4	0.2	0.1	0.03	0.012	0.01	0.01

YA-Frame - Miniature Circuit Breakers

Time Delay Curve

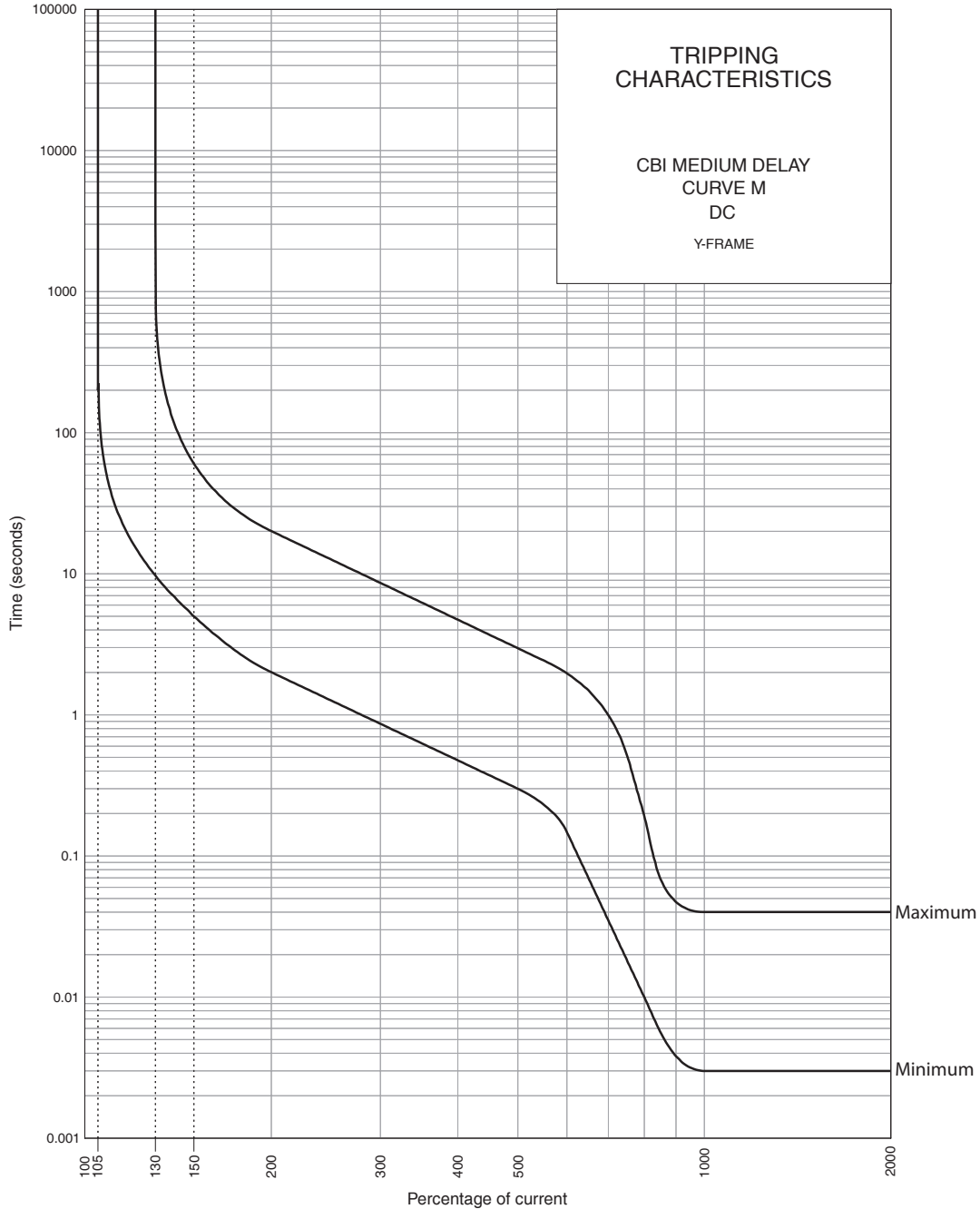

3990A883 REV. B

PERCENTAGE OF RATED CURRENT	105%	130%	150%	200%	300%	400%	500%	600%	700%	800%	900%	1000%	1200%
MINIMUM TRIP TIME IN SECONDS	NO TRIP	9.7	4.99	2.0	0.9	0.48	0.3	0.15	0.03	0.01	0.004	0.003	0.003
MAXIMUM TRIP TIME IN SECONDS	NO TRIP	3000	60.0	20.0	8.62	4.7	3.0	1.97	0.99	0.19	0.05	0.04	0.04

YA-Frame - Miniature Circuit Breakers

Time Delay Curve

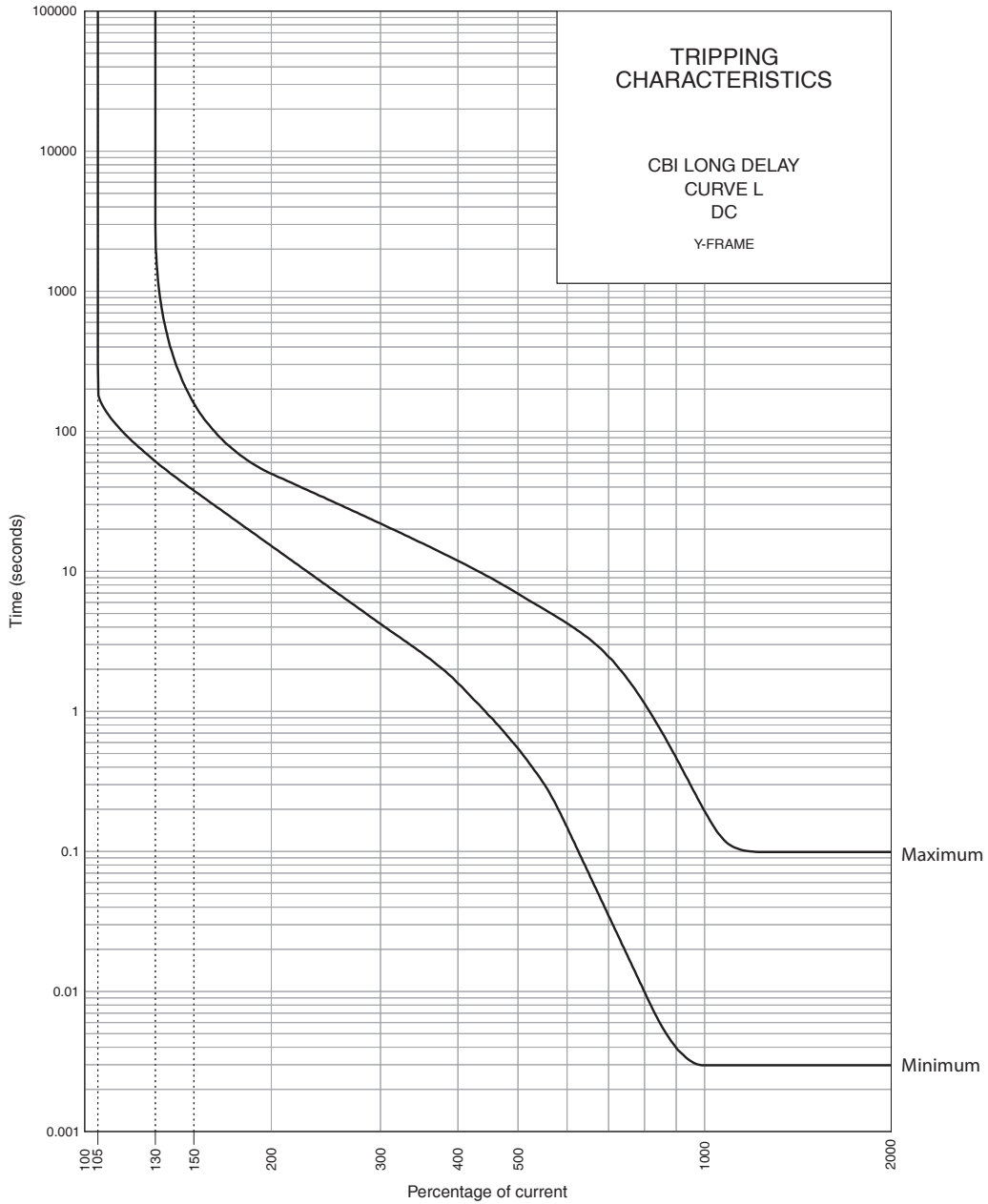

PERCENTAGE OF RATED CURRENT	105%	130%	150%	200%	300%	400%	500%	600%	700%	800%	900%	1000%	1200%
MINIMUM TRIP TIME IN SECONDS	NO TRIP	60.9	37.7	15.2	4.2	1.6	0.54	0.15	0.03	0.01	0.004	0.003	0.003
MAXIMUM TRIP TIME IN SECONDS	NO TRIP	3000	158.3	49.8	21.98	11.9	6.9	4.3	2.5	1.1	0.5	0.2	0.1

YA-Frame - Miniature Circuit Breakers

DIN mounting 45 mm escutcheon			DIN mounting 57 mm escutcheon	
AMP	BOM No.	Long Code	BOM No.	Long Code
One pole (13 mm total width) 300 Vdc Polarised, Positive Bottom				
0.5 A	YAD1M0A5B03	YAD-1(13)-M-0.5A-B03	YAM1M0A5B03	YAM-1(13)-M-0.5A-B03
1 A	YAD1M001B03	YAD-1(13)-M-1A-B03	YAM1M001B03	YAM-1(13)-M-1A-B03
2 A	YAD1M002B03	YAD-1(13)-M-2A-B03	YAM1M002B03	YAM-1(13)-M-2A-B03
3 A	YAD1M003B03	YAD-1(13)-M-3A-B03	YAM1M003B03	YAM-1(13)-M-3A-B03
5 A	YAD1M005B03	YAD-1(13)-M-5A-B03	YAM1M005B03	YAM-1(13)-M-5A-B03
6 A	YAD1M006B03	YAD-1(13)-M-6A-B03	YAM1M006B03	YAM-1(13)-M-6A-B03
10 A	YAD1M010B03	YAD-1(13)-M-10A-B03	YAM1M010B03	YAM-1(13)-M-10A-B03
15 A	YAD1M015B03	YAD-1(13)-M-15A-B03	YAM1M015B03	YAM-1(13)-M-15A-B03
16 A	YAD1M016B03	YAD-1(13)-M-16A-B03	YAM1M016B03	YAM-1(13)-M-16A-B03
20 A	YAD1M020B03	YAD-1(13)-M-20A-B03	YAM1M020B03	YAM-1(13)-M-20A-B03
25 A	YAD1M025B03	YAD-1(13)-M-25A-B03	YAM1M025B03	YAM-1(13)-M-25A-B03
30 A	YAD1M030B03	YAD-1(13)-M-30A-B03	YAM1M030B03	YAM-1(13)-M-30A-B03
32 A	YAD1M032B03	YAD-1(13)-M-32A-B03	YAM1M032B03	YAM-1(13)-M-32A-B03
35 A	YAD1M035B03	YAD-1(13)-M-35A-B03	YAM1M035B03	YAM-1(13)-M-35A-B03
40 A	YAD1M040B03	YAD-1(13)-M-40A-B03	YAM1M040B03	YAM-1(13)-M-40A-B03
45 A	YAD1M045B03	YAD-1(13)-M-45A-B03	YAM1M045B03	YAM-1(13)-M-45A-B03
50 A	YAD1M050B03	YAD-1(13)-M-50A-B03	YAM1M050B03	YAM-1(13)-M-50A-B03
Two pole (26 mm total width) 300 Vdc Polarised (1 + 1 = 2 Pole) - Positive bottom, Positive top				
0.5 A	YAD2M0A5BT3	YAD-2(13)-M-0.5A-BT3	YAM2M0A5BT3	YAM-2(13)-M-0.5A-BT3
1 A	YAD2M001BT3	YAD-2(13)-M-1A-BT3	YAM2M001BT3	YAM-2(13)-M-1A-BT3
2 A	YAD2M002BT3	YAD-2(13)-M-2A-BT3	YAM2M002BT3	YAM-2(13)-M-2A-BT3
3 A	YAD2M003BT3	YAD-2(13)-M-3A-BT3	YAM2M003BT3	YAM-2(13)-M-3A-BT3
5 A	YAD2M005BT3	YAD-2(13)-M-5A-BT3	YAM2M005BT3	YAM-2(13)-M-5A-BT3
6 A	YAD2M006BT3	YAD-2(13)-M-6A-BT3	YAM2M006BT3	YAM-2(13)-M-6A-BT3
10 A	YAD2M010BT3	YAD-2(13)-M-10A-BT3	YAM2M010BT3	YAM-2(13)-M-10A-BT3
15 A	YAD2M015BT3	YAD-2(13)-M-15A-BT3	YAM2M015BT3	YAM-2(13)-M-15A-BT3
16 A	YAD2M016BT3	YAD-2(13)-M-16A-BT3	YAM2M016BT3	YAM-2(13)-M-16A-BT3
20 A	YAD2M020BT3	YAD-2(13)-M-20A-BT3	YAM2M020BT3	YAM-2(13)-M-20A-BT3
25 A	YAD2M025BT3	YAD-2(13)-M-25A-BT3	YAM2M025BT3	YAM-2(13)-M-25A-BT3
30 A	YAD2M030BT3	YAD-2(13)-M-30A-BT3	YAM2M030BT3	YAM-2(13)-M-30A-BT3
32 A	YAD2M032BT3	YAD-2(13)-M-32A-BT3	YAM2M032BT3	YAM-2(13)-M-32A-BT3
35 A	YAD2M035BT3	YAD-2(13)-M-35A-BT3	YAM2M035BT3	YAM-2(13)-M-35A-BT3
40 A	YAD2M040BT3	YAD-2(13)-M-40A-BT3	YAM2M040BT3	YAM-2(13)-M-40A-BT3
45 A	YAD2M045BT3	YAD-2(13)-M-45A-BT3	YAM2M045BT3	YAM-2(13)-M-45A-BT3
50 A	YAD2M050BT3	YAD-2(13)-M-50A-BT3	YAM2M050BT3	YAM-2(13)-M-50A-BT3

YA-Frame - Miniature Circuit Breakers

DIN mounting 45 mm escutcheon			DIN mounting 57 mm escutcheon	
AMP	BOM No.	Long Code	BOM No.	Long Code
Four pole - (52 mm total width) 400 Vdc Polarised, series connection, (2 + 2 = 4 Pole) - connection @Bottom (Bottom positive, Bottom negative / Bottom negative, Bottom positive)				
0.5 A	YAD4M0A5BU4	YAD-4(13)-M-0.5A-BU4	YAM4M0A5BU4	YAM-4(13)-M-0.5A-BU4
1 A	YAD4M001BU4	YAD-4(13)-M-1A-BU4	YAM4M001BU4	YAM-4(13)-M-1A-BU4
2 A	YAD4M002BU4	YAD-4(13)-M-2A-BU4	YAM4M002BU4	YAM-4(13)-M-2A-BU4
3 A	YAD4M003BU4	YAD-4(13)-M-3A-BU4	YAM4M003BU4	YAM-4(13)-M-3A-BU4
5 A	YAD4M005BU4	YAD-4(13)-M-5A-BU4	YAM4M005BU4	YAM-4(13)-M-5A-BU4
6 A	YAD4M006BU4	YAD-4(13)-M-6A-BU4	YAM4M006BU4	YAM-4(13)-M-6A-BU4
10 A	YAD4M010BU4	YAD-4(13)-M-10A-BU4	YAM4M010BU4	YAM-4(13)-M-10A-BU4
15 A	YAD4M015BU4	YAD-4(13)-M-15A-BU4	YAM4M015BU4	YAM-4(13)-M-15A-BU4
16 A	YAD4M016BU4	YAD-4(13)-M-16A-BU4	YAM4M016BU4	YAM-4(13)-M-16A-BU4
20 A	YAD4M020BU4	YAD-4(13)-M-20A-BU4	YAM4M020BU4	YAM-4(13)-M-20A-BU4
25 A	YAD4M025BU4	YAD-4(13)-M-25A-BU4	YAM4M025BU4	YAM-4(13)-M-25A-BU4
30 A	YAD4M030BU4	YAD-4(13)-M-30A-BU4	YAM4M030BU4	YAM-4(13)-M-30A-BU4
Two pole (26 mm total width) 600 Vdc - Series connection				
0.5 A	YAD2M0A5BT6	YAD-2(13)-M-0.5A-BT6	YAM2M0A5BT6	YAM-2(13)-M-0.5A-BT6
1 A	YAD2M001BT6	YAD-2(13)-M-1A-BT6	YAM2M001BT6	YAM-2(13)-M-1A-BT6
2 A	YAD2M002BT6	YAD-2(13)-M-2A-BT6	YAM2M002BT6	YAM-2(13)-M-2A-BT6
3 A	YAD2M003BT6	YAD-2(13)-M-3A-BT6	YAM2M003BT6	YAM-2(13)-M-3A-BT6
5 A	YAD2M005BT6	YAD-2(13)-M-5A-BT6	YAM2M005BT6	YAM-2(13)-M-5A-BT6
6 A	YAD2M006BT6	YAD-2(13)-M-6A-BT6	YAM2M006BT6	YAM-2(13)-M-6A-BT6
10 A	YAD2M010BT6	YAD-2(13)-M-10A-BT6	YAM2M010BT6	YAM-2(13)-M-10A-BT6
15 A	YAD2M015BT6	YAD-2(13)-M-15A-BT6	YAM2M015BT6	YAM-2(13)-M-15A-BT6
16 A	YAD2M016BT6	YAD-2(13)-M-16A-BT6	YAM2M016BT6	YAM-2(13)-M-16A-BT6
20 A	YAD2M020BT6	YAD-2(13)-M-20A-BT6	YAM2M020BT6	YAM-2(13)-M-20A-BT6
25 A	YAD2M025BT6	YAD-2(13)-M-25A-BT6	YAM2M025BT6	YAM-2(13)-M-25A-BT6
30 A	YAD2M030BT6	YAD-2(13)-M-30A-BT6	YAM2M030BT6	YAM-2(13)-M-30A-BT6
32 A	YAD2M032BT6	YAD-2(13)-M-32A-BT6	YAM2M032BT6	YAM-2(13)-M-32A-BT6
35 A	YAD2M035BT6	YAD-2(13)-M-35A-BT6	YAM2M032BT6	YAM-2(13)-M-35A-BT6
40 A	YAD2M040BT6	YAD-2(13)-M-40A-BT6	YAM2M040BT6	YAM-2(13)-M-40A-BT6
45 A	YAD2M045BT6	YAD-2(13)-M-45A-BT6	YAM2M045BT6	YAM-2(13)-M-45A-BT6
50 A	YAD2M050BT6	YAD-2(13)-M-50A-BT6	YAM2M050BT6	YAM-2(13)-M-50A-BT6

Note:

The "M" after the number in the Re-order number i.e. YAD2M0A5B04 represents the time delay tripping curves

If a different curve is required please replace the "M" with the appropriate curve

YA-Frame - Miniature Circuit Breakers

Possible used Connections Diagrams

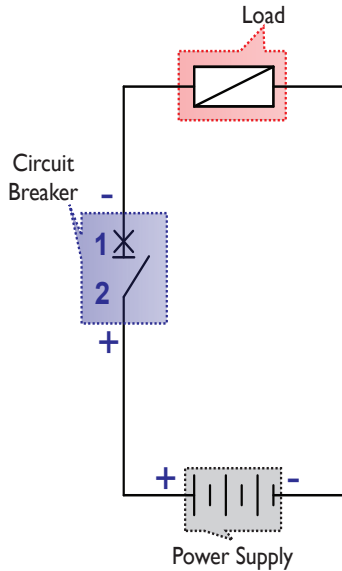

**Figure 1:
Single Pole, Single Break
(300 Vdc)**

Figure 1: Single Pole, Single Break (300 Vdc - B03)

This circuit makes use of a single pole circuit breaker connected in series with the load.

Figure 2: Double Pole, Single Break (600 Vdc - BT6)

This circuit makes use of a double pole circuit breaker connected in series with the load.

**Figure 3: Double Pole, Double Break. Isolates load
(300 Vdc, 400 Vdc, 600 Vdc - B03)**

This circuit makes use of a double pole circuit breaker where the load is between the contacts, providing full isolation to the load.

**Figure 4: Double Pole, Double Break. Isolates load
(300 Vdc, 400 Vdc, 600 Vdc - BT3)**

This circuit makes use of a double pole circuit breaker where the load is between the contacts, providing full isolation to the load.

**Figure 5: Four Pole, Double Break. Isolates Load
(400 Vdc - BU4)**

This circuit makes use of a four pole circuit breaker where the load is between the contacts, providing full isolation to the load.

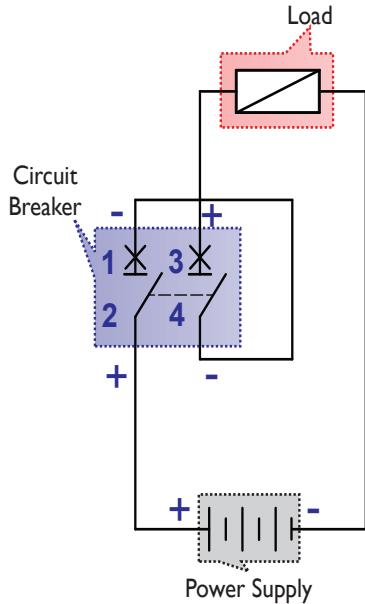

**Figure 2:
Double Pole, Single Break
(600 Vdc)**

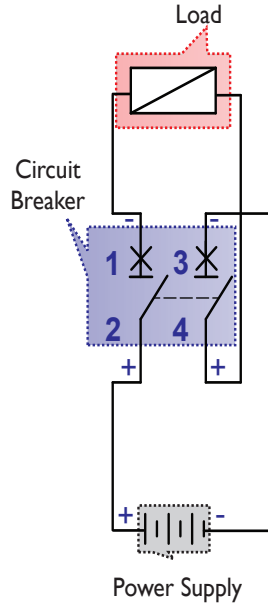

**Figure 3:
Double Pole, Double Break.
Isolates Load
(300 Vdc, 400 Vdc, 600 Vdc)**

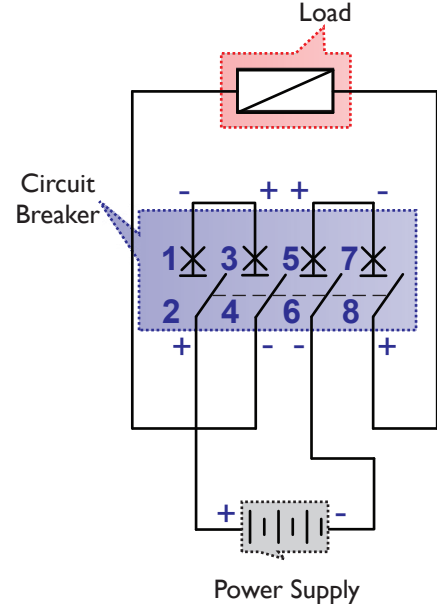

**Figure 4:
Four Pole, Double Break.
Isolates Load
(400 Vdc)**

Notes:

1. Products are rated at 300 Vdc per pole, and will function at voltages below rated voltage.
2. Other types of connections are possible.
3. Products are NOT Reverse feedable

YA-Frame - Miniature Circuit Breakers

Outline Dimensions: DIN Mount 45 mm front Escutcheon (Grey)

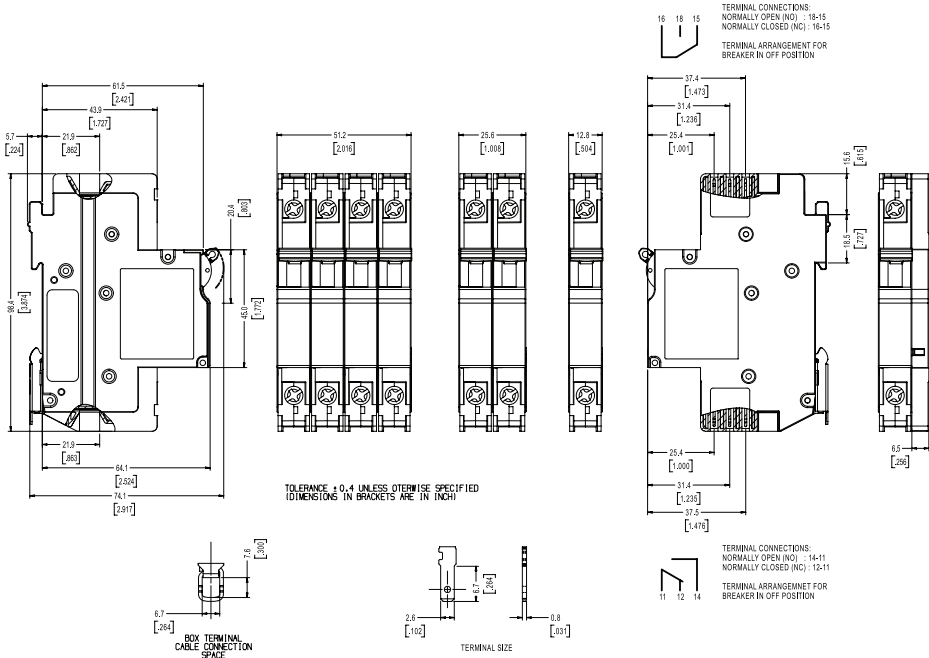

Outline Dimensions: DIN Mount 57 mm front Escutcheon (Black)

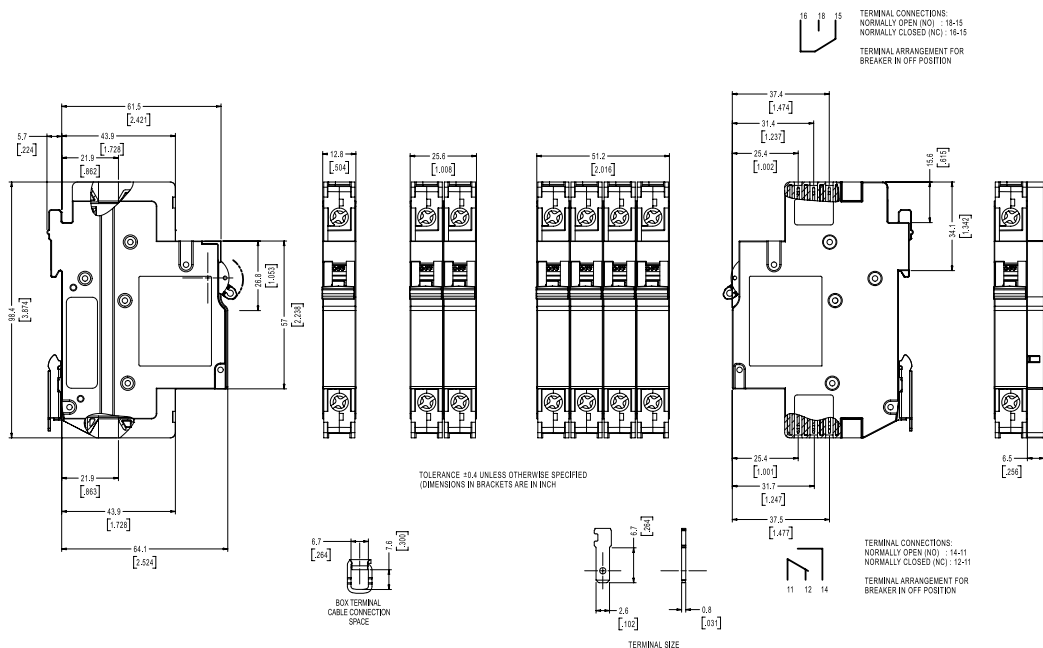

Please review our Customer Terms and Conditions on www.cbi-lowvoltage.co.za

© CBI (Pty) Ltd. All Rights Reserved.

All rights reserved. Unless otherwise indicated, all materials on these pages are copyrighted by CBI (Pty) Ltd. No part of these pages, either text or image may be used for any purpose other than personal use. Therefore, reproduction, modification, storage in a retrieval system or retransmission, in any form or by any means, electronic, mechanical or otherwise, for reasons other than personal use, is strictly prohibited without prior written permission. CBI (Pty) Ltd reserves the right to alter any details of this document without notice and while every effort is made to ensure the accuracy of the content, no warranty is given as to the accuracy of this document and no responsibility will be accepted for error or misinterpretation and any resulting loss.

AUSTRALIA
CBI-electric: Australia
27 Wedgewood Rd, Hallam
Victoria 3803 Australia
Tel: +61 3 8752 9300
Fax: +61 3 9796 5407
Email: sales@cbi-electric.com.au
Website: www.cbi-electric.com.au

INDIA
CBI-electric: Asia
A1, Pushpagiri Residency, 1st Cross
2nd Main, Jyothi Nagar, B.G Road
Bengaluru 560083, India
Tel: +91-9880553153
Email: salesasia@cbi-electric.com
Website: www.cbibreakers.com
Website: www.cbi-lowvoltage.com

SOUTH AFRICA
CBI-electric: low voltage
Tripswitch Drive Elandsfontein
Gauteng South Africa
Tel: +27 11 928 2000
Fax: +27 11 392 2354
Email: cbi@cbi-electric.com
internationalsales@cbi-electric.com
Website: www.cbi-lowvoltage.co.za

USA
CBI-electric: North America
35 E. Uwchlan Ave Suite 328
Exton PA 19341 USA
Tel: +1 610 524 9949
Fax: +1 610 524 9945
E-mail: info@cbibreakers.com
Website: www.cbibreakers.com