

Motor and Pump Protection Relays

777-ACCUPOWER

3-Phase Current & Voltage Monitor



Description

The 777 AccuPower is a fully-programmable, 3-phase motor and pump protection relay. It allows for entry of motor hp rating, full-load amperes, efficiency, and power factors, and will then accurately calculate motor output power. The 777 AccuPower relay is most useful with mag-drive pumps or process applications where the process power is desired over the utility power. Voltage, current, and power measurements can be displayed as well as fault information and setpoints. The built-in display simplifies troubleshooting and allows the user to easily and precisely configure setpoints.

The 777 AccuPower can be used with the optional COM 4-20 output communication module to give an analog signal proportional to output shaft power. Other optional accessories include the RS485MS-2W comms module; the RM1000 remote monitor; and the RM2000 remote monitor. See the accessories products for complete information.

Features & Benefits

FEATURES	BENEFITS
Built-in display	Visual indication for programming, viewing real-time voltage or current, and last fault code
Motor output power measurement	Allows use of process power over utility power
Network communications capability	Limited Modbus capabilities using RS485MS-2W communications module
3 programmable restart delay timers	Allows separate restart delay time for rapid cycle protection, motor cool down, and dry-well recovery
Remote display compatibility	Increases safety through remote display of real-time data and fault history. Aids with arc-flash safety regulations

Applications

- For use with mag-drive pumps or process applications where the process power is desired over the utility power

Motor and Pump Protection Relays

777-ACCUPOWER

Specifications

Input Characteristics

Line Voltage	200-480 V ac
Frequency	50/60 Hz
Motor Full Load Amp Range	2-800 A (external CTs required over 90 A)

Functional Characteristics

TC- Overcurrent Trip Class	5, 10, 15, 20, 30 (J prefix enables jam protection feature)
-----------------------------------	---

Output Characteristics

Output Contact Rating (SPDT - Form C)	
Pilot duty	480 VA @ 240 V ac
General Purpose	10 A @ 240 V ac

General Characteristics

Ambient Temperature Range	
Operating	-40 °C to 70 °C (-40 °F to 158 °F)
Storage	-40 °C to 80 °C (-40 °F to 176 °F)

Accuracy

Measured Horsepower/Kilowatt	
Typical	±3 %*
Voltage	±1 %
Current	±3 % (<100 amps direct)
GF Current	±15 %
Timing	5 % ±1 second

Repeatability

Voltage	±0.5 % of nominal voltage
Current	±1 % (<100 amps direct)
Maximum Input Power	10 W
Pollution Degree	3
Class of Protection	IP20, NEMA 1 (finger safe)
Relative Humidity	10-95 %, non-condensing per IEC 68-2-3
Terminal Torque	7 in.-lbs.

Standards Passed

Electrostatic Discharge	(ESD) IEC 61000-4-2, Level 3, 6 kV contact, 8 kV air
Radio Frequency Immunity (RFI)	
Conducted	IEC 61000-4-6, Level 3 10 V/m
Radiated	IEC 61000-4-3, Level 3 10 V/m
Fast Transient Burst	IEC 61000-4-4, Level 3, 3.5 kV input power
Short Circuit Rating	100 kA

Surge

IEC	61000-4-5 Level 3, 2 kV line-to-line; Level 4, 4 kV line-to-ground
ANSI/IEEE	C62.41 Surge and Ring Wave Compliance to a level of 6 kV line-to-line
Hi-Potential Test	Meets UL 508 (2 x rated V + 1000 V for 1 min.)
Vibration	IEC 68-2-6, 10-55 Hz, 1 mm peak-to-peak, 2 hrs, 3 axis
Shock	IEC 68-2-27, 30 g, 3 axis, 11 ms duration, half-sine pulse
Max. Conductor Size through 777	0.65" with insulation
Dimensions	H 77.47 mm (3.05"); W 97.79 mm (3.85"); D 128.27 mm (5.05")
Weight	1.3 lbs. (20.8 oz., 589.67 g)
Mounting Method	Surface mount (4 - #8 screws) or DIN-rail mount

*On a well balanced system within recommended current range.

Certification & Compliance

UL	UL 508, UL 1053
CE	IEC 60947-1, IEC 60947-5-1
CSA	C22.2

Motor and Pump Protection Relays

777-ACCUPOWER

Ordering Information

MODEL	LINE VOLTAGE	MOTOR FULL AMP RANGE
777-ACCUPOWER	190 - 480 V ac	2 - 25: 3 phase (looped conductors required) 25 - 90: 3 phase (direct) 80 - 800: 3 phase (external CTs)

Accessories

RS485MS-2W Communication Module

(for limited Modbus capabilities) Required to enable the Modbus communications function on Model 77X-type products.

COM 4-20 Output Communication Module

This module allows communication to a PLC with an analog input and no Modbus input.

RM1000 Remote Monitor

The RM1000/777 motor management system combines unsurpassed electronic motor protection and critical, user-friendly, motor monitoring for up to 16 devices.

RM2000 Remote Monitor

The RM2000/777 motor management system combines unsurpassed electronic motor protection and critical, user-friendly, motor monitoring with event storage and real-time clock for date and time stamp.

Dimensions Inches (mm)

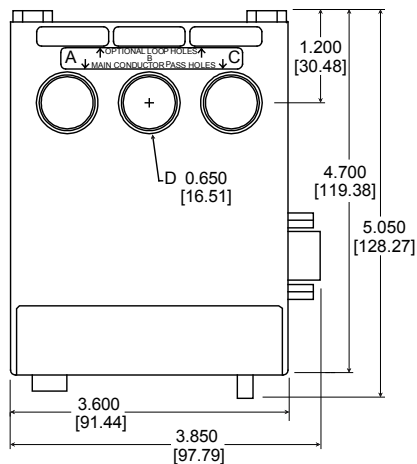
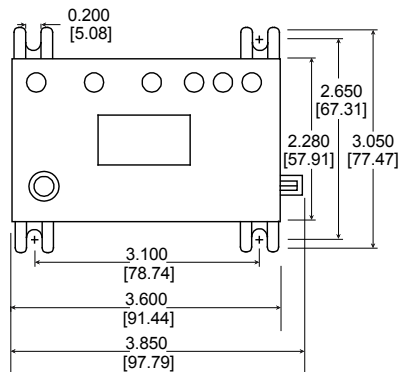

Motor and Pump Protection Relays

777-ACCUPOWER

Simplified Wiring Diagram

TYPICAL WIRING DIAGRAM FOR MODEL 777-ACCUPOWER

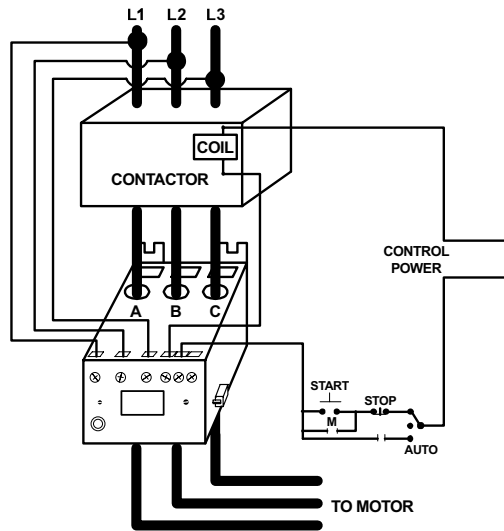
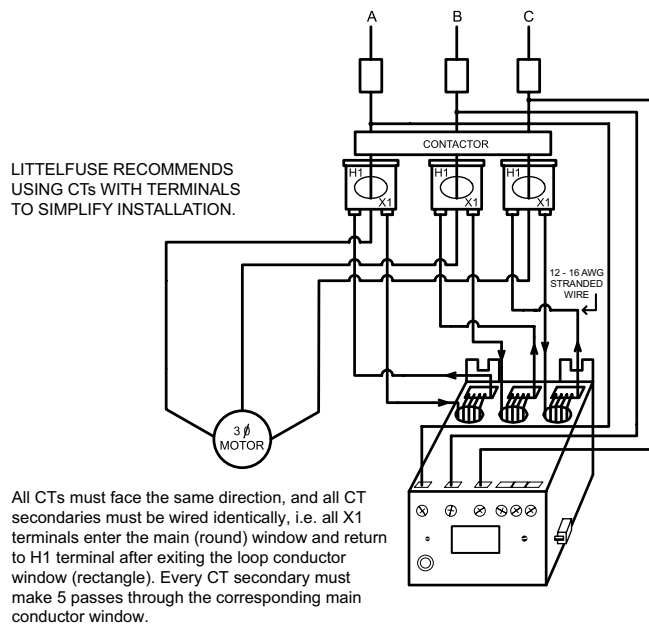

Figure 1: Typical Wiring Diagram

CURRENT TRANSFORMER WIRING DIAGRAM FOR MODEL 777-ACCUPOWER



Disclaimer Notice – Information furnished is believed to be accurate and reliable. However, users should independently evaluate the suitability of and test each product selected for their own applications. Littelfuse products are not designed for, and may not be used in, all applications. Read complete Disclaimer Notice at www.littelfuse.com/product-disclaimer.