

## 1-pole Solid State Contactors with Current Sensing



### Description

This slim RG design is capable of detecting various failure modes occurring to the heaters and also to the product itself. Failures which can be detected include partial load failure, heater loss, open circuit SSR, short circuit SSR and SSR over temperature. A normally closed, potential free alarm, opens in the event of a system or power semiconductor fault.

A load current setpoint has to be TEACHED to the SSR either locally by the TEACH button on the front of the device or remotely through the provided terminal.

This product is available either with integrated heatsink (RGC1S series) and also without heatsink (RGS1S series). The minimum product width is 22.5 mm. The control and auxiliary terminals are double box clamps to facilitate safe looping whilst the power terminals are either screw terminals or box clamps depending on the model selected.

Specifications are at a surrounding temperature of 25°C unless otherwise specified.

### Applications

Injection moulding, PET blow moulding, Blow moulding, Blow film extrusion, Thermoforming, Food packaging machines, Wrapping and sealing machines.

### Main features

- Partial load failure detection
- Zero cross switching with ratings up to 660 VACrms & 85 AACrms @ 40°C
- Local or remote current setpoint
- Alarm signal output for SSR or load circuit malfunction

### Benefits

- **Panel space savings.** The slimmest product footprint is only 22.5 mm up to 30 AAC.
- **Less maintenance costs.** Wire bonding technology reduces thermal and mechanical stresses of the output chips resulting in a larger number of operational cycles compared to other assembly technologies.
- **Low machine downtime.** Integrated overvoltage protection prevents the solid state relay from breaking down due to uncontrolled transients that may occur on the lines.
- **Ease of use.** The RGC ready-to-use solution is provided with integrated heatsink thus eliminating the need for the user to calculate the size of heatsink needed for adequate thermal dissipation.
- **Cost effective protection co-ordination.** The high I<sup>2</sup>t specification permits easy Type 2 protection co-ordination with B-type Miniature Circuit Breakers.
- **Fast wiring.** Power connections for models rated >30 A are equipped with terminals that can handle cables up to 25 mm<sup>2</sup> / AWG3 cables.
- **Accommodates UL508A requirements for Industrial Control Panels.** The RGC is certified as a listed product. All models carry a 100 kArms Short Circuit Current Rating.
- **Protection against SSR overheat.** Integrated over temperature protection protects the RGC output from getting damaged in case of overheating.

**Order code**

**RGC1S60D**  **G**   **P**

 Enter the code option instead of . Refer to the selection guide section for valid part numbers.

Code	Option	Description	Comments
<b>R</b>	-	Solid State Relay (RG)	
<b>G</b>	-		
<b>C</b>	-	With integrated heatsink	
<b>1</b>	-	1-pole switching	
<b>S</b>	-	Current sensing	
<b>60</b>	-	Rated voltage: 42 - 660 VAC, 1200 Vp	
<b>D</b>	-	Control input: 4 - 32 VDC	
<input type="checkbox"/>	<b>25</b>	Rated current: 25 AAC (1800 A <sup>2</sup> s)	
	<b>26</b>	Rated current: 25 AAC (18000 A <sup>2</sup> s)	
	<b>30</b>	Rated current: 30 AAC (1800 A <sup>2</sup> s)	
	<b>31</b>	Rated current: 30 AAC (6600 A <sup>2</sup> s)	
	<b>41</b>	Rated current: 43 AAC (18000 A <sup>2</sup> s)	
	<b>61</b>	Rated current: 65 AAC (18000 A <sup>2</sup> s)	
	<b>90</b>	Rated current: 85 AAC (18000 A <sup>2</sup> s)	
<b>G</b>	-	Box clamp connection for control terminals	
<input type="checkbox"/>	<b>K</b>	Screw connection for power terminals	
	<b>G</b>	Box clamp connection for power terminals	
<input type="checkbox"/>	<b>E</b>	Contact configuration	
	<b>U</b>	SSR configuration	Only available with box clamp power terminals
<b>P</b>	-	Over temperature protection	

## Selection guide

Selection guide for GKEP variants

Rated voltage, Blocking voltage	Connection Control / Power	Control voltage	Config-uration	Rated operational current (I <sup>2</sup> t)		
				25 AAC (1800 A <sup>2</sup> s)	30 AAC (1800 A <sup>2</sup> s)	30 AAC (6600 A <sup>2</sup> s)
				Product width		
				22.5 mm	22.5 mm	22.5 mm
600 VAC, 1200 Vp	Box clamp / Screw	4 - 32VDC	E	RGC1S60D25GKEP	RGC1S60D30GKEP	RGC1S60D31GKEP

## Selection guide

Selection guide for GGEP and GGUP variants

Rated voltage, Blocking voltage	Connection Control / Power	Control voltage	Config-uration	Rated operational current (I <sup>2</sup> t)			
				25 AAC (18000 A <sup>2</sup> s)	43 AAC (18000 A <sup>2</sup> s)	65 AAC (18000 A <sup>2</sup> s)	85 AAC (18000 A <sup>2</sup> s)
				Product width			
				22.5 mm	35 mm	70 mm	70 mm + fan
600 VAC, 1200 Vp	Box clamp / Box clamp	4 - 32 VDC	E	RGC1S60D26GGEP	RGC1S60D41GGEP	RGC1S60D61GGEP	RGC1S60D90GGEP
	Box clamp / Box clamp	4 - 32 VDC	U	-	RGC1S60D41GGUP	RGC1S60D61GGUP	-

## Carlo Gavazzi further reading

Information	Where to find it	Notes
Datasheet	<a href="https://gavazziautomation.com/images/PIM/DATA-SHEET/ENG/SSR_RGS1S.pdf">https://gavazziautomation.com/images/PIM/DATA-SHEET/ENG/SSR_RGS1S.pdf</a>	Solid state relay, RGS1S (Current sensing relay without heatsink)

# Structure

RGC1S..GKEP

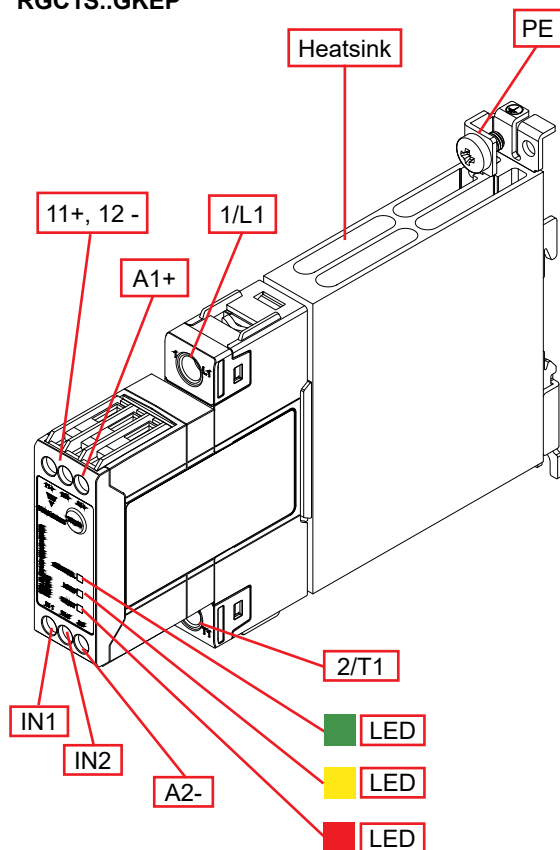

RGC1S..GGEP

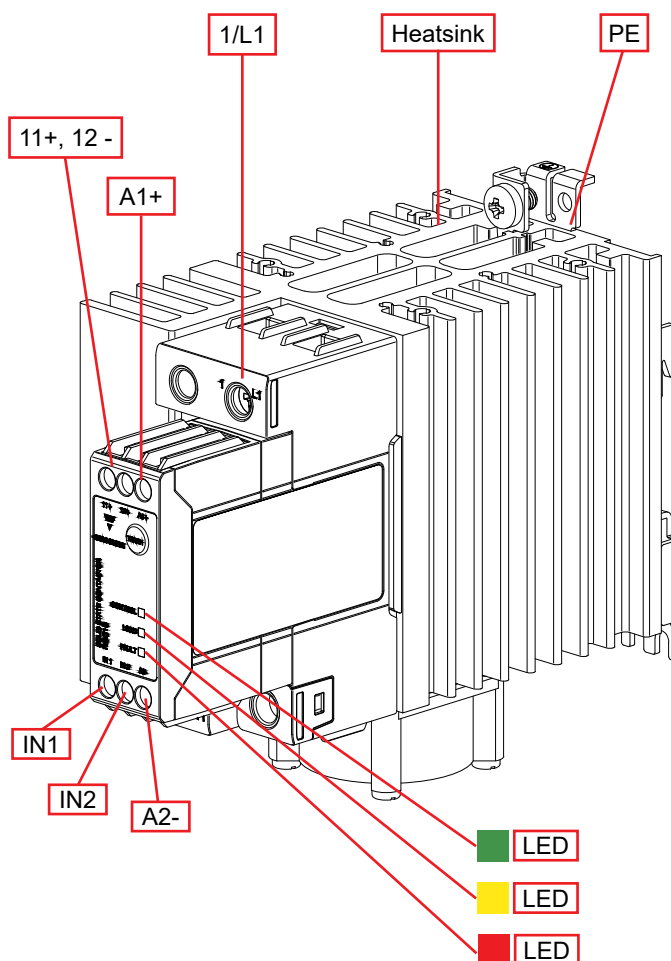

Element	Component	Function
1/L1	Power connection	Mains connection
2/T1	Power connection	Load connection
A1 +	Supply connection	External supply connection
A2 -	Ground connection	Ground connection for both the external supply and control voltage
11+, 12 -	Alarm connection	Alarm output signal, normally closed
IN1	Remote TEACH signal	Terminal for external supply for TEACH function
IN2	Control voltage	Connection for control voltage
Green LED	Control indicator	Indicates presence of control voltage
Yellow LED	Load indicator	Indicates presence of load ON
Red LED	Fault indicator	Indicates presence of a fault
Heatsink	Integrated heatsink	DIN rail mounting (panel mounting also possible)
PE	Protective Earth	Connection for Protective Earth, PE screw not provided with RGC1S

# Features

## General data

<b>Material</b>	PA66 or PA6 (UL94 V0), RAL7035 Glow wire ignition temperature and Glow wire flammability index conform to EN 60335-1 requirements	
<b>Mounting</b>	DIN rail (panel mounting also possible)	
<b>Touch Protection</b>	IP20	
<b>Overvoltage Category</b>	III, 6 kV (1.2/50 $\mu$ s) rated impulse withstand voltage	
<b>Isolation</b>	Input to Output IN1, IN2, A1+, A2- to L1, T1	2500 Vrms
	Alarm to Output 11+, 12- to L1, T1	2500 Vrms
	Alarm to Input 11+, 12- to A1+, A2-, IN1, IN2	500 Vrms
	Input & Output to Case	4000 Vrms
<b>LED status indication<sup>1</sup></b>	Supply ON Control ON	Green half intensity Green full intensity
	Load ON	Yellow
	Fault	Red <sup>1</sup>
<b>Weight</b>	RGC1S..25.., RGC1S..26.. RGC1S..30.., RGC1S..31.. RGC1S..41.. RGC1S..61.. RGC1S..90..	approx. 344 g approx. 414 g approx. 583 g approx. 974 g approx. 1102 g

1. Refer to Alarm management

## Performance

### Output specifications

	RGC1S..25	RGC1S..26	RGC1S..30
Operational voltage range	42 - 600 VAC +10% -15% on max		
Blocking voltage	1200 Vp		
Max. operational current <sup>2</sup> : AC - 51 @ Ta = 25°C	27 AAC	30 AAC	30 AAC
Max. operational current <sup>2</sup> : AC - 51 @ Ta = 40°C	25 AAC	25 AAC	30 AAC
Minimum TEACH Current <sup>3</sup>	1.2 AAC		
Minimum partial load current	0.2 AAC		
Detectable partial load failure	>16.67% from current setpoint for more than 120 ms		
Operational frequency range	45 to 65 Hz		
Output protection	Integrated varistor		
Leakage current @ rated voltage	<3 mAAC		
Repetitive overload current UL508: Ta = 40°C, t <sub>ON</sub> = 1 s, t <sub>OFF</sub> = 9 s, 50 cycles, PF = 0.9	60 AAC	60 AAC	84 AAC
Non-repetitive surge current (I <sub>TSM</sub> ), t = 10 ms	600 Ap	1900 Ap	600 Ap
I <sup>2</sup> t for fusing (t = 10 ms), min.	1800 A <sup>2</sup> s	18000 A <sup>2</sup> s	1800 A <sup>2</sup> s
Power factor	>0.9 at rated voltage		
Critical dV/dt (@Tj init = 40°C)	1000 V/μs		

	RGC1S..31	RGC1S..41	RGC1S..61	RGC1S..90
Operational voltage range	42 - 600 VAC +10% -15% on max			
Blocking voltage	1200 Vp			
Max. operational current <sup>2</sup> : AC - 51 @ Ta = 25°C	30 AAC	50 AAC	75 AAC	85 AAC
Max. operational current <sup>2</sup> : AC - 51 @ Ta = 40°C	30 AAC	43 AAC	65 AAC	85 AAC
Minimum TEACH Current <sup>3</sup>	1.2 AAC		5 AAC	
Minimum partial load current	0.2 AAC	0.2 AAC	0.2 AAC	0.2 AAC
Detectable partial load failure	>16.67% from current setpoint for more than 120 ms			
Operational frequency range	45 to 65 Hz			
Output protection	Integrated varistor			
Leakage current @ rated voltage	<3 mAAC			
Repetitive overload current UL508: Ta = 40°C, t <sub>ON</sub> = 1 s, t <sub>OFF</sub> = 9 s, 50 cycles, PF = 0.9	84 AAC	126 AAC	168 AAC	168 AAC
Non-repetitive surge current (I <sub>TSM</sub> ), t = 10 ms	1150 Ap	1900 Ap	1900 Ap	1900 Ap
I <sup>2</sup> t for fusing (t = 10 ms), min.	6600 A <sup>2</sup> s	18000 A <sup>2</sup> s	18000 A <sup>2</sup> s	18000 A <sup>2</sup> s
Power factor	>0.9 at rated voltage			
Critical dV/dt (@Tj init = 40°C)	1000 V/μs			

2. Refer to Current derating
3. Refer to EMC specifications

### Supply specifications (A1+, A2-)

Supply voltage range (Us)	24 VDC -15%, +20%
Reverse protection	Yes
Max. supply current	50 mA
Fan supply (RGC1S..90)	supplied directly to fan 24 VDC +/-10%, 50 mA nominal

### Control specifications (IN2)

Control voltage range <sup>4,5</sup>	4 - 32 VDC
Pick-up voltage	3.8 VDC
Drop-out voltage	1 VDC
Maximum reverse voltage	32 VDC
Input current	refer to chart
Max Response time pick-up	0.5 cycle + 500 $\mu$ s @ 24 VDC
Min Response time drop-out	0.5 cycle + 500 $\mu$ s @ 24 VDC

### Remote TEACH (IN1)

Control voltage range <sup>4</sup>	4 - 32 VDC
Input current	refer to chart
Reverse protection	Yes

### Alarm specifications (11+, 12-)

Output type	PNP Open Collector
Normal state <sup>6</sup>	Normally Closed
Maximum rating	35 Vdc, 50m ADC
Visual Indication	Red LED <sup>7</sup>
Alarm output onstate voltage	Refer to chart

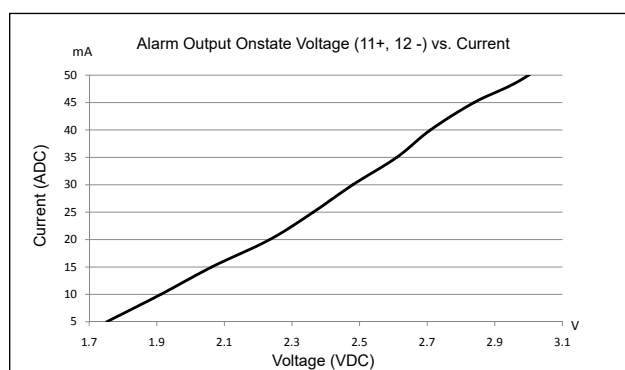
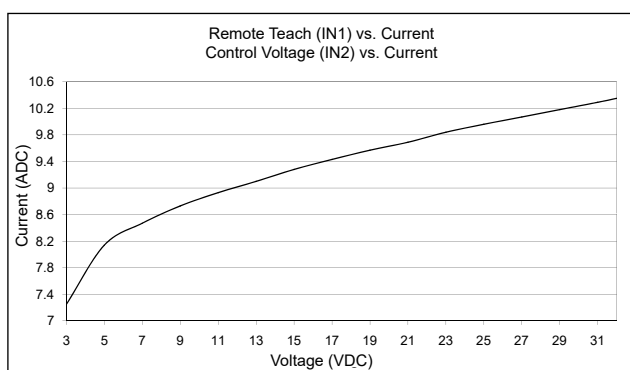

4. DC control to be supplied by a Class 2 power source
5. A partial load failure will not be detected if the ON time is less than 120ms
6. The alarm will open when the supply voltage (A1, A2) is removed
7. Refer to Alarm management

**Output power dissipation**

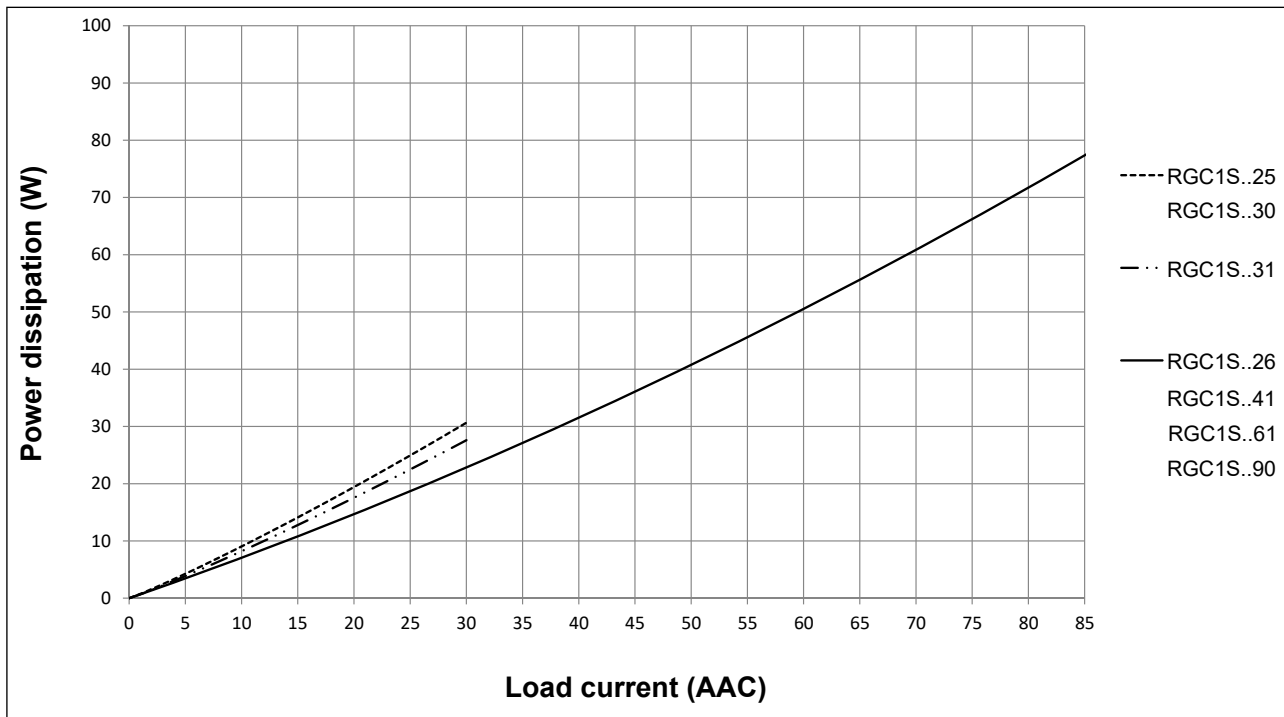

**Current derating (UL508)**

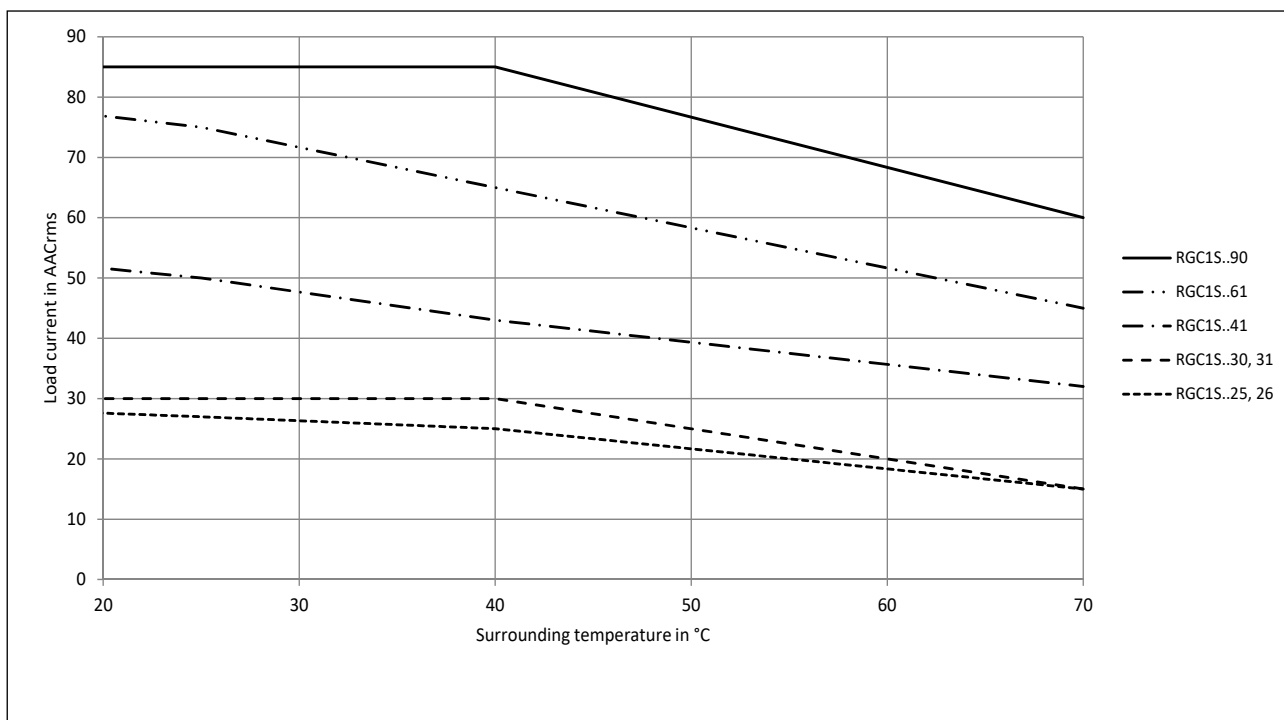

**Derating vs. spacing curves**

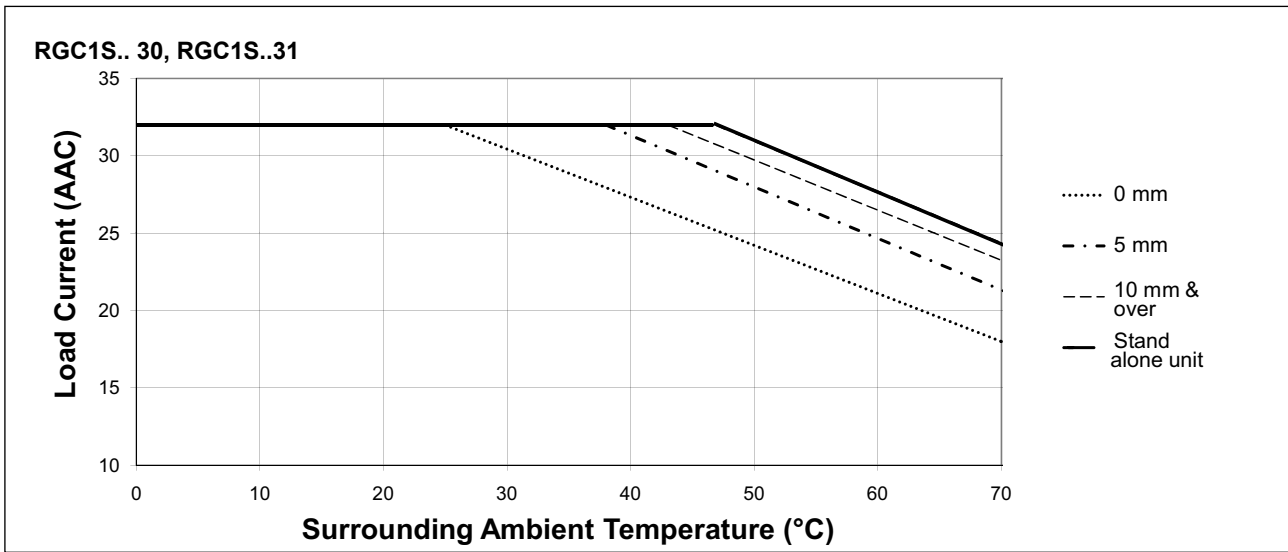
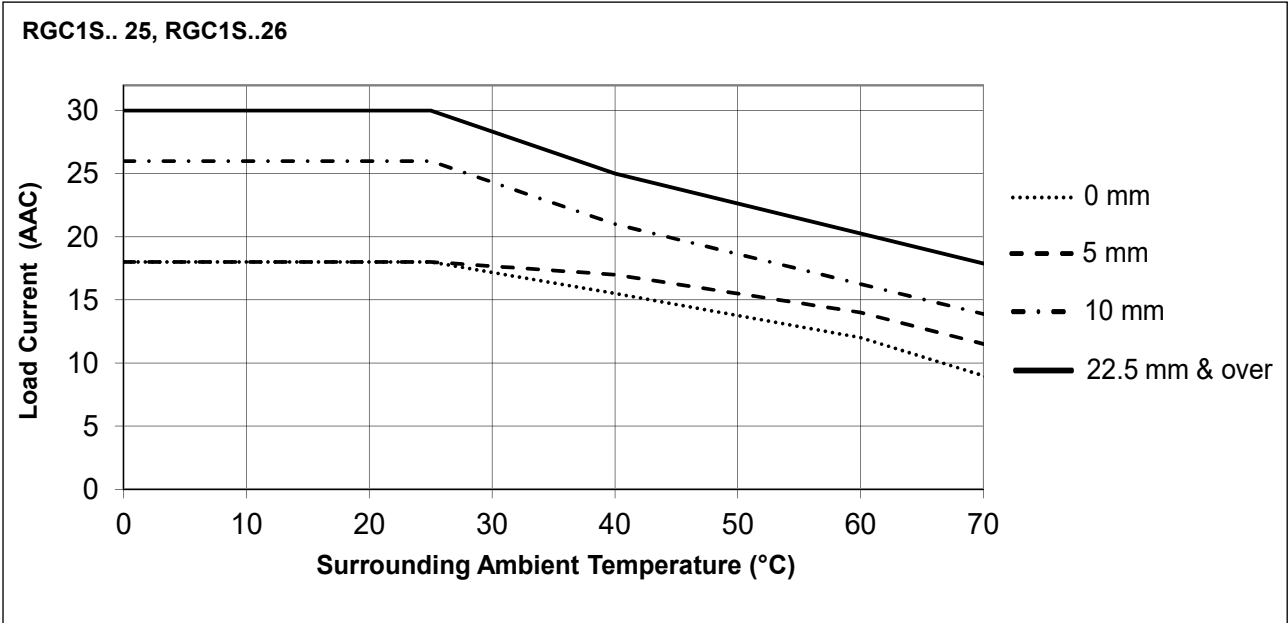

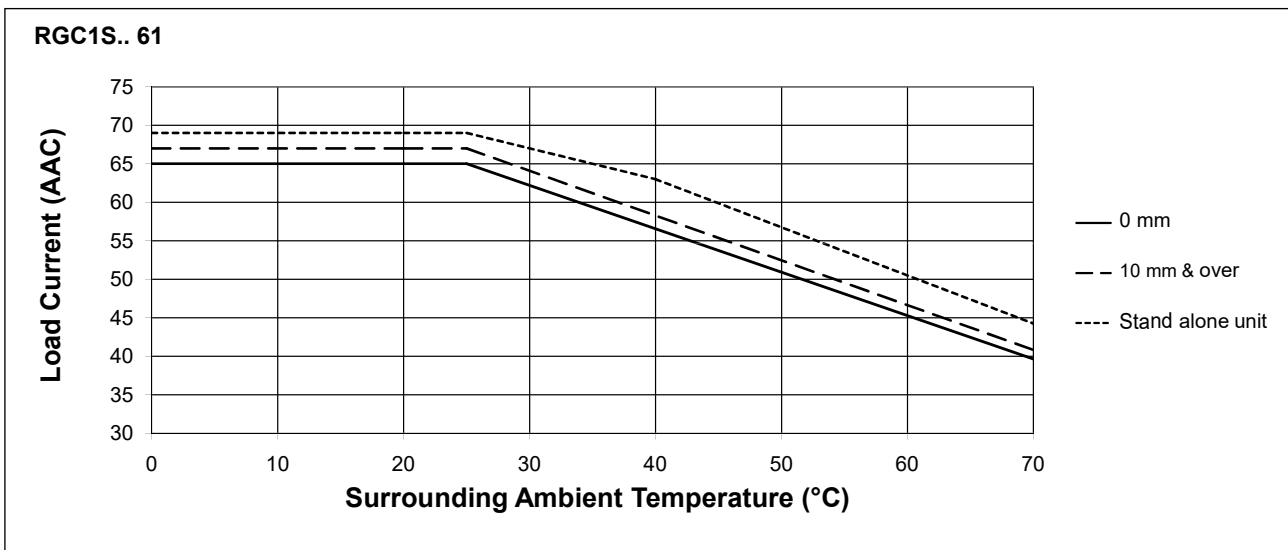
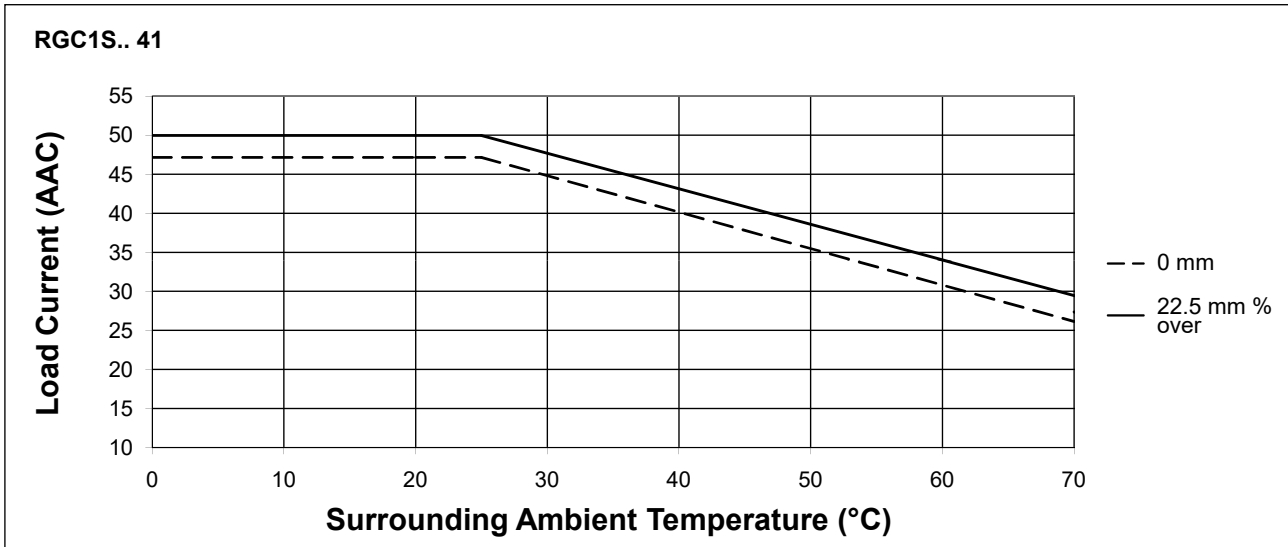

▶ Derating vs. spacing curves

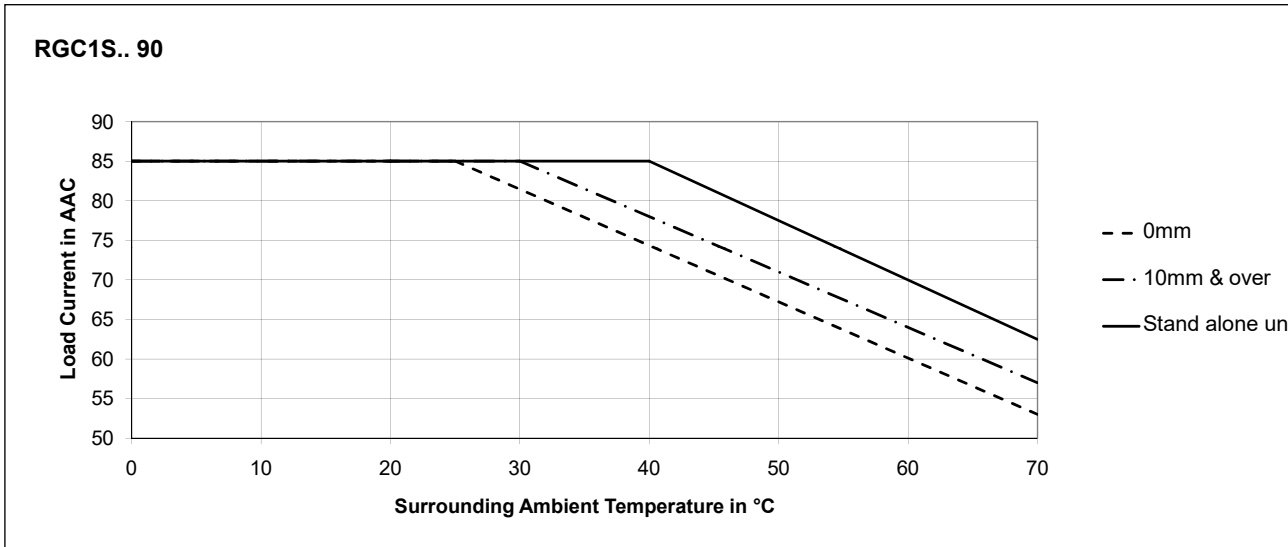

▶ Derating vs. spacing curves



## Compatibility and conformance

<b>Approvals</b>	  
<b>Standards compliance</b>	LVD: EN 60947-4-3 EMCD: EN 60947-4-3 UL: UL508 (E172877), NMFT cUL: C22.2 No. 14 (E172877), NMFT7
<b>UL short circuit current rating</b>	100k Arms (refer to short circuit current section, Type 1 – UL508)

<b>Electromagnetic compatibility (EMC) - Immunity</b>	
<b>Electrostatic discharge (ESD)</b>	EN/IEC 61000-4-2 8 kV air discharge, 4 kV contact (PC1)
<b>Radiated radio frequency</b>	EN/IEC 61000-4-3 10 V/m, from 80 MHz to 1 GHz (PC1) 10 V/m, from 1.4 to 2 GHz (PC1) 3 V/m, from 2 to 2.7 GHz (PC1)
<b>Electrical fast transient (burst)</b>	EN/IEC 61000-4-4 Output: 2 kV, 5 kHz (PC2) Input: 1kV, 5kHz (PC1)
<b>Conducted radio frequency</b>	EN/IEC 61000-4-6 10 V/m, from 0.15 to 80 MHz (PC1)
<b>Electrical surge</b>	EN/IEC 61000-4-5 Output, line to line: 1 kV (PC1) Output, line to earth: 2 kV (PC1) DC lines, line to line, 500V (PC2) DC lines, line to earth, 500V (PC2) Signal lines, line to earth, 1kV (PC2)
<b>Voltage dips</b>	EN/IEC 61000-4-11 0% for 0.5, 1 cycle (PC2) 40% for 10 cycles (PC2) 70% for 25 cycles (PC2) 80% for 250 cycles (PC2)
<b>Voltage interruptions</b>	EN/IEC 61000-4-11 0% for 5000 ms (PC2)

<b>Electromagnetic compatibility (EMC) - Emissions</b>	
<b>Radio interference field emission (radiated)</b>	EN/IEC 55011 Class A: from 30 to 1000 MHz
<b>Radio interference voltage emissions (conducted)</b>	EN/IEC 55011 Class A: from 0.15 to 30 MHz (External filter may be required - refer to Filtering section)

### Note:

- Control input lines must be installed together to maintain products' susceptibility to Radio Frequency interference.
- Use of AC solid state relays may, according to the application and the load current, cause conducted radio interferences. Use of mains filters may be necessary for cases where the user must meet E.M.C requirements. The capacitor values given inside the filtering specification tables should be taken only as indications, the filter attenuation will depend on the final application.
- Performance Criteria 1 (PC1): No degradation of performance or loss of function is allowed when the product is operated as intended.
- Performance Criteria 2 (PC2): During the test, degradation of performance or partial loss of function is allowed. However when the test is complete the product should return operating as intended by itself.
- Performance Criteria 3 (PC3): Temporary loss of function is allowed, provided the function can be restored by manual operation of the controls.

**Filter connection diagram**

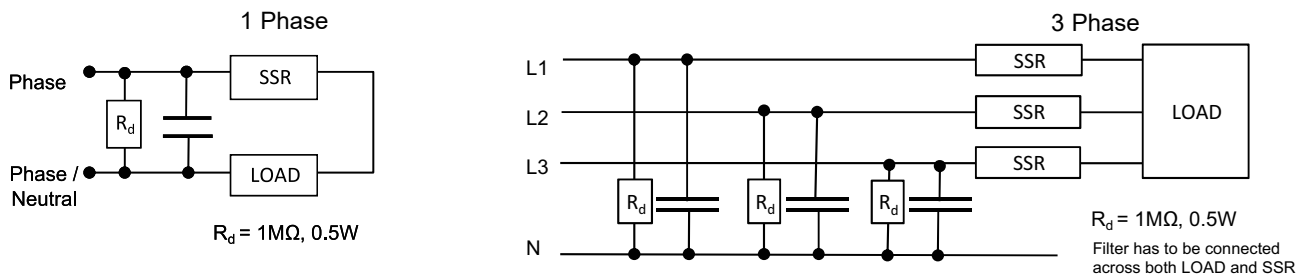

**Filtering**

Part number	Suggested filter for EN 55011 Class A compliance	Maximum heater current
RGC1S60D25GKEP	220 nF / 760 V / X1	25 AAC
RGC1S60D26GGEP	330 nF / 760 V / X1	25 AAC
RGC1S60D30GKEP	220 nF / 760 V / X1	30 AAC
RGC1S60D31GKEP	220 nF / 760 V / X1	30 AAC
RGC1S60D41GG.P	330 nF / 760 V / X1	40 AAC
RGC1S60D61GG.P	680 nF / 760 V / X1	65 AAC
RGC1S60D90GGEP	680 nF / 760 V / X1	65 AAC

## Environmental specifications

<b>Operating temperature</b>	-25°C to 70°C (-13°F to +158°F)
<b>Storage temperature</b>	-40°C to +100°C (-40°F to +212°F)
<b>Relative humidity</b>	95% non-condensing @ 40°C
<b>Pollution degree</b>	2
<b>Installation altitude</b>	0-1000 m. Above 1000 m derate linearly by 1% of FLC per 100 m up to a maximum of 2000 m
<b>Vibration resistance</b>	2g / axis (2-100Hz, IEC 60068-2-6, EN 50155, EN 61373)
<b>Impact resistance</b>	15/11 g/ms (EN50155, EN61373)
<b>EU RoHS compliant</b>	Yes
<b>China RoHS</b>	

The declaration in this section is prepared in compliance with People's Republic of China Electronic Industry Standard SJ/T11364-2014: Marking for the Restricted Use of Hazardous Substances in Electronic and Electrical Products.

Part Name	Toxic or Harardous Substances and Elements					
	Lead (Pb)	Mercury (Hg)	Cadmium (Cd)	Hexavalent Chromium (Cr(VI))	Polybrominated biphenyls (PBB)	Polybrominated diphenyl ethers (PBDE)
<b>Power Unit Assembly</b>	x	o	o	o	o	o

O: Indicates that said hazardous substance contained in homogeneous materials for this part are below the limit requirement of GB/T 26572.

X: Indicates that said hazardous substance contained in one of the homogeneous materials used for this part is above the limit requirement of GB/T 26572.

这份申明根据中华人民共和国电子工业标准  
SJ/T11364-2014：标注在电子电气产品中限定使用的有害物质

零件名称	有毒或有害物质与元素					
	铅 (Pb)	汞 (Hg)	镉 (Cd)	六价铬 (Cr(VI))	多溴化联苯 (PBB)	多溴联苯醚 (PBDE)
功率单元	x	o	o	o	o	o

O:此零件所有材料中含有的该有害物低于GB/T 26572的限定。

X: 此零件某种材料中含有的该有害物高于GB/T 26572的限定。

**Mode of operation**

**Introduction:**

The RGC1S must have a stored current setpoint to operate as a Solid State Relay with a Sensing function. The current setpoint is the nominal operating current that is expected through the SSR when all heater loads are functioning properly. The SSR is shipped without having a stored setpoint. This current setpoint is to be stored upon a TEACH procedure as explained below. The wrong setpoint is stored if the heater loads are faulty or the mains supply voltage is not close to operating voltage during the TEACH procedure.

**Caution:** In case of a brand new RGC1S (i.e. an RGC1S that does not have a stored current set point), a TEACH procedure on no load (i.e. no load connected to the RGC1S load terminal 2/T1) will result in a stored current set point of 0A.

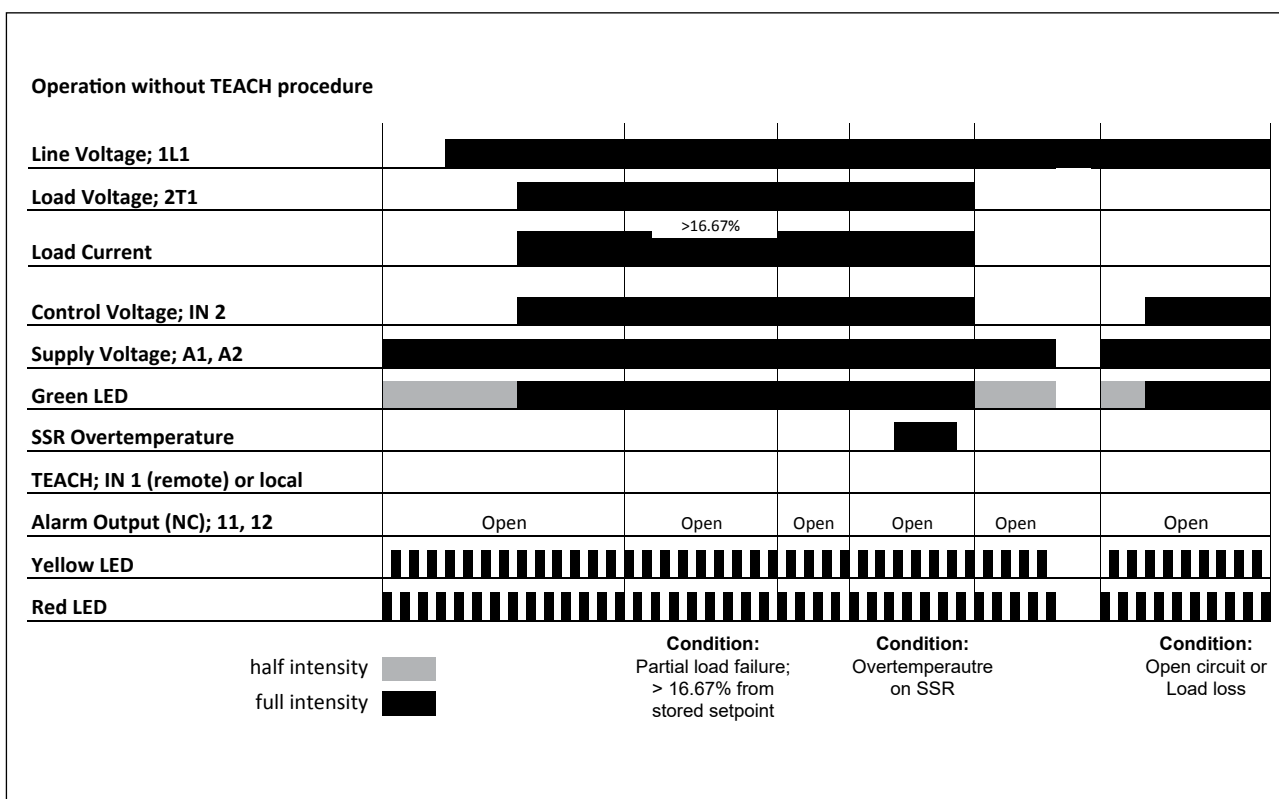

Upon application of supply voltage, the yellow and red LED will flash continuously in sequence (i.e., scroll) indicating that the device has no current setpoint stored. The green LED is ON at half intensity indicating the presence of supply voltage. As soon as control voltage is applied the green LED will be ON at full intensity. The alarm output, which is normally closed, is open to indicate that the SSR has no stored setpoint.

If mains supply is present upon application of control voltage the SSR will switch ON despite having no stored current setpoint. However, even though the SSR switches ON, the Sensing features associated with the RGC1S are disabled as shown in the above operations diagram. The Sensing features will be enabled ONLY once the TEACH procedure explained below is completed. For SSR to switch ON upon application of control voltage, supply voltage has to be present across terminals A1, A2.

## Mode of operation (cont.)

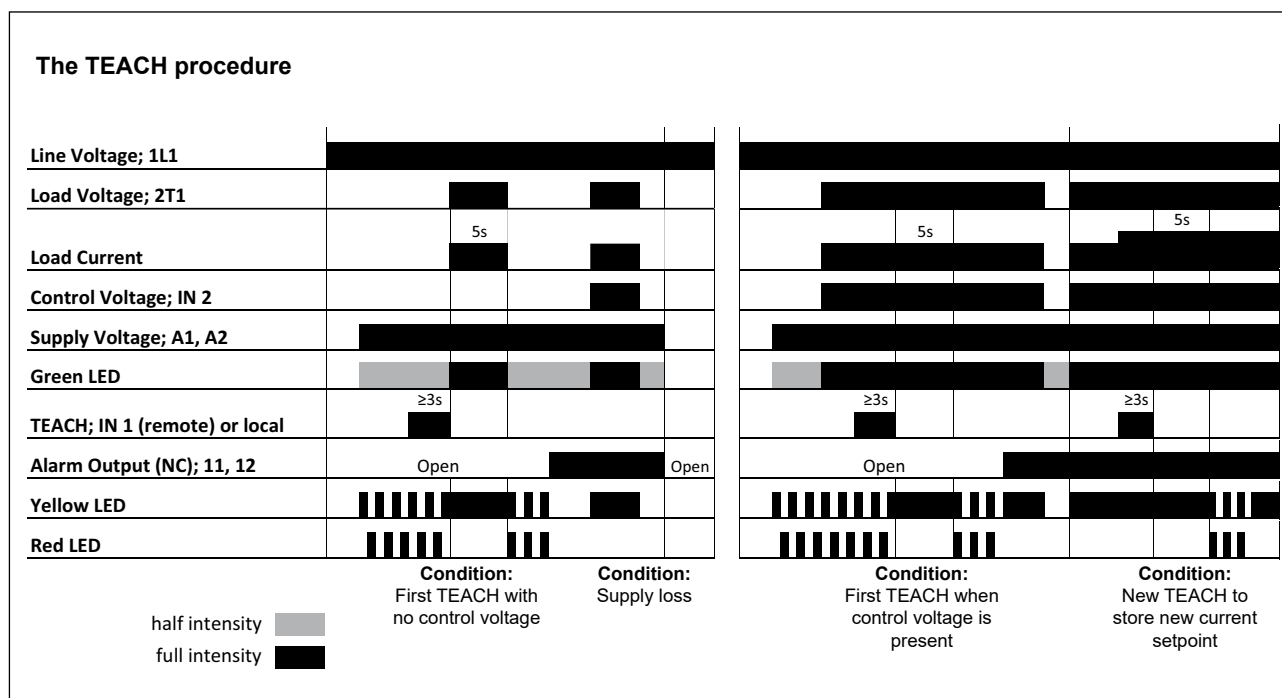

The TEACH procedure can be performed either locally or remotely. For local TEACH, the front 'TEACH' button on the SSR has to be pressed for at least 3 seconds (but less than 5 seconds). Remote TEACH can be performed by applying a high signal on terminal IN 1 for a duration of at least 3 seconds (but less than 5 seconds).

Supply voltage has to be present across terminals A1, A2 for the TEACH function to be performed and SSR to operate

### TEACH in the absence of a control signal

It is possible to TEACH the SSR without the presence of a control signal. In case of no previous stored setpoint (factory default), red and yellow LED will flash accordingly indicating this. The TEACH function will start as soon as the push button is released. The SSR will switch fully ON for 5 seconds (yellow LED ON during these 5 seconds) at the end of which, a load current setpoint is recorded. If TEACH procedure is successful the yellow and red LED will blink together for three times to indicate a successful setpoint measurement. The alarm output across terminals 11, 12 closes indicating a normal situation.

In case of an unsuccessful TEACH, the red & yellow LED will scroll continuously indicating that no current setpoint is stored. If load current does not stabilise during the 5 seconds TEACH sequence, it will not be possible to store setpoint. Another attempt to do a TEACH may be done until setpoint is recorded.

### TEACH when control signal is present

In this case the TEACH procedure is identical to the TEACH procedure when there is no control signal. During the 5 seconds TEACH the status of the load switching will not be distinguished from unTEACHed state since load was ON before TEACH. Load remains ON as long as control voltage is present.

If SSR is in a LOCKed position (see below) it will not be possible to perform a new TEACH. SSR has to be unLOCKed first.

## Mode of operation (cont.)

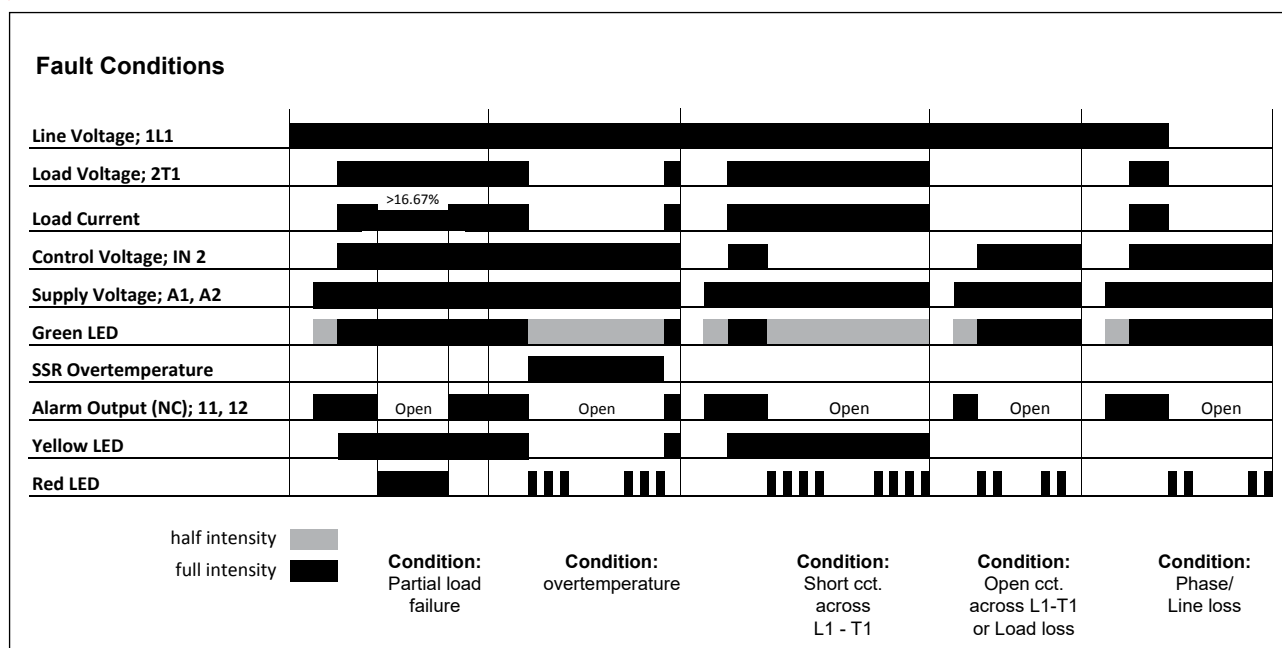

### Partial Load Failure

This occurs when the load current decreases by more than 16.67% as compared to the stored setpoint. During this failure mode the SSR remains ON but alarm output opens to indicate an alarm condition. The red LED is continuously ON during this condition. If current rises back to normal levels the alarm indications switch to the normal state.

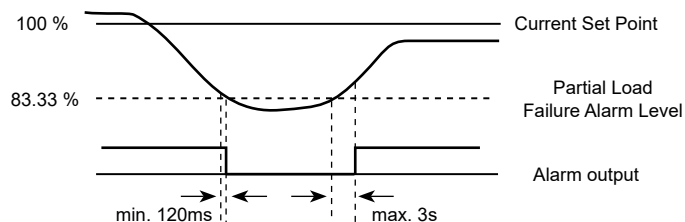

### Over Temperature

If the SSR derating curve is exceeded during normal operation, an over-temperature condition is detected and the SSR output switches OFF. A visual alarm is indicated by the red blinking LED (3 flashes - see details in ALARM LED INDICATIONS) and alarm signal opens. The alarm resets automatically when the overtemperature condition is no longer present.

### SSR Short Circuit

This condition is detected in the absence of a control signal and load current (in the region of 800mA and over) still flowing through the SSR. A visual indication is given by the red blinking LED (4 flashes - see details in ALARM LED INDICATIONS) and open alarm across terminals 11, 12. The yellow LED stays ON even though the green LED is at halfintensity (i.e. absence of control input voltage) to indicate status of load.

### SSR Open Circuit / Heater Loss / Line Loss

SSR output remains OFF even after application of the control voltage on terminal IN 2. A visual indication is given by the red blinking LED (2 flashes - see details in ALARM LED INDICATIONS) and open alarm across terminals 11, 12.



### Alarm auto reset

In all alarm conditions described above, the alarm LED and signal output from terminals 11, 12 reset automatically to the normal condition as soon as the alarm condition is no longer present. There is no need for an alarm reset.

### Alarm auto reset

The device can be locked to prevent undesirable local TEACH. This can be done by sending a pulse with a duration between 1s and 1.5s to the remote TEACH terminal IN 1. To TEACH a LOCKed unit, a pulse with duration between 1s and 1.5s has to be applied first to terminal IN 1, before performing the TEACH. The initial condition of the unit after every power up (through A1, A2 terminals) is UNLOCKed.

**LED indicators**

<b>CONTROL</b>	Green 	Half intensity Full intensity OFF	Supply ON, Control OFF Supply ON, Control ON Supply OFF, Control OFF
<b>LOAD</b>	Yellow 	ON OFF	Load ON Load OFF
<b>FAULT</b>	Red 	ON	Fully ON or flashing when alarm condition is present. Refer to Alarm management section
		OFF	No alarm condition

**Alarm management**

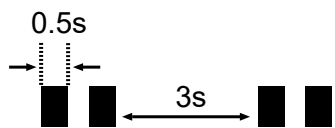
<b>Alarm condition present</b>	<ul style="list-style-type: none"> <li>The state of the Red LED of the RGC1S is ON with a specific flashing rate</li> <li>Alarm output operates</li> </ul>	
<b>Alarm types</b>	<b>No. of flashes</b>	<b>Description of fault</b>
	100% ON	Partial Load Failure
	50% ON	No TEACH setpoint
	1	Locked TEACH
	2	Open SSR / Heater
	3	SSR Overtemperature
	4	SSR Short Circuit
<b>Flashing rate</b>		

## Short circuit protection

### Protection Co-ordination, Type 1 vs Type 2:

Type 1 protection implies that after a short circuit, the device under test will no longer be in a functioning state. In type 2 co-ordination the device under test will still be functional after the short circuit. In both cases, however the short circuit has to be interrupted. The fuse between the enclosure and supply shall not open. The door or cover of the enclosure shall not be blown open. There shall be no damage to conductors or terminals and the conductors shall not separate from the terminals. There shall be no breakage or cracking of insulating bases to the extent that the integrity of the mounting of live parts is impaired. Discharge of parts or any risk of fire shall not occur.

The product variants listed in the table hereunder are suitable for use on a circuit capable of delivering not more than 100,000A Symmetrical Amperes, 600Volts maximum when protected by fuses. Tests at 100,000Arms were performed with Class J fuses, fast acting; please refer to the tables below for maximum ratings. Tests with Class J fuses are representative of Class CC fuses.

Protection co-ordination Type 1 according to UL 508				
Part No.	Prospective short circuit current [kArms]	Max fuse size [A]	Class	Voltage [VAC]
RGC1S60D25GKEP	100	30	J or CC	Max. 600
RGC1S60D26GGEP		30	J or CC	
RGC1S60D30GKEP		30	J or CC	
RGC1S60D31GKEP		40	J	
RGC1S60D41GG.P		90	J	
RGC1S60D61GG.P		90	J	
RGC1S60D90GGEP		90	J	

Protection co-ordination Type 2 (IEC/EN 60947-4-2/ -4-3)						
Part No.	Prospective short circuit current [kArms]	Ferraz Shawmut (Mersen)		Siba		Max. voltage [VAC]
		Max fuse size [A]	Part number	Max fuse size [A]	Part number	
RGC1S..25, 26, 30, 31	10	40	6.6xx CP URD 22x58 / 40	32	50 142 06.32	600
	100					
RGC1S..41	10	63	6.9xx CP URC 14x51 / 63	80	50 194 20.80	
		70	A70QS70-4			
	100	63	6.9xx CP URC 14x51 / 63			
		70	A70QS70-4			
RGC1S..61	10	100	6.9xx CP GRC 22x58 / 100 A70QS100-4	100	50 194 20.100	
	100	100	6.621 CP URGD 27x60 / 100 A70QS100-4			
RGC1S..90	10	125	6.621 CP URQ 27x60 / 125	125	50 194 20.125	
	100	125	A70QS125-4			

xx = 00, without fuse trip indication, xx= 21, with fuse trip indication

Protection co-ordination Type 2 with Miniature Circuit Breakers (M.C.B.s)				
Solid State Relay type	ABB Model no. for Z - type M. C. B. (rated current)	ABB Model no. for B - type M. C. B. (rated current)	Wire cross sectional area [mm <sup>2</sup> ]	Minimum length of Cu wire conductor [m] <sup>8</sup>
RGC1S..25 RGC1S..30 (1800 A <sup>2</sup> s)	S201 - Z10 (10 A)	S201 - B4 (4 A)	1.0	7.6
			1.5	11.4
			2.5	19.0
	S201 - Z16 (16 A)	S201 - B6 (6 A)	1.0	5.2
			1.5	7.8
			2.5	13.0
			4.0	20.8
	S201 - Z20 (20 A)	S201 - B10 (10 A)	1.5	12.6
			2.5	21.0
	S201 - Z25 (25 A)	S201 - B13 (13 A)	2.5	25.0
		4.0	40.0	
S202 - Z25 (25 A)	S202 - B13 (13 A)	2.5	19.0	
		4.0	30.4	
RGC1S..31 (6600 A <sup>2</sup> s)	S201 - Z20 (20 A)	S201 - B10 (10 A)	1.5	4.2
			2.5	7.0
			4.0	11.2
	S201 - Z32 (32 A)	S201 - B16 (16 A)	2.5	13.0
			4.0	20.8
			6.0	31.2
	S202 - Z20 (20 A)	S202 - B10 (10 A)	1.5	1.8
			2.5	3.0
			4.0	4.8
	S202 - Z32 (32 A)	S202 - B16 (16 A)	2.5	5.0
4.0			8.0	
6.0			12.0	
10.0			20.0	
S202 - Z50 (50A )	S202 - B25 (25 A)	4.0	14.8	
		6.0	22.2	
		10.0	37.0	
RGC1S..26 RGC1S..41 RGC1S..61 RGC1S..90 (18000 A <sup>2</sup> s)	S201 - Z32 (32 A)	S201 - B16 (16 A)	2.5	3.0
			4.0	4.8
			6.0	7.2
	S201 - Z50 (50 A)	S201 - B25 (25 A)	4.0	4.8
			6.0	7.2
			10.0	12.0
			16.0	19.2
	S201 - Z63 (63 A)	S201-B32 (32 A)	6.0	7.2
			10.0	12.0
			16.0	19.2

8. Between MCB and Load (including return path which goes back to the mains)

Note: A prospective current of 6 kA and a 230 / 400 V power supply is assumed for the above suggested specifications. For cables with different cross section than those mentioned above please consult Carlo Gavazzi's Technical Support Group.

S201 models refer to 1-pole M.C.B., S202 models refer to 2-poles M.C.B.

**Dimensions**

**RGC1S60D25GKEP**

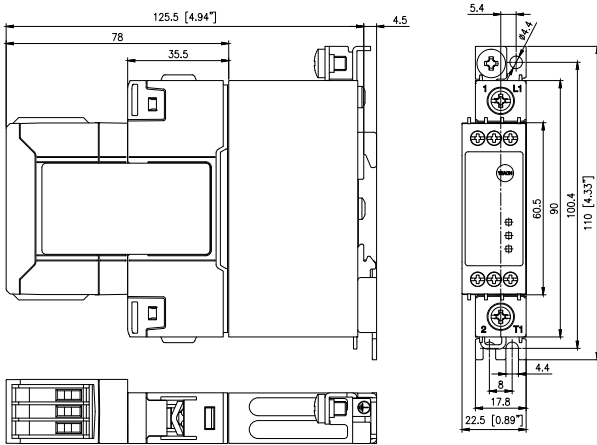

**RGC1S60D26GGEp**

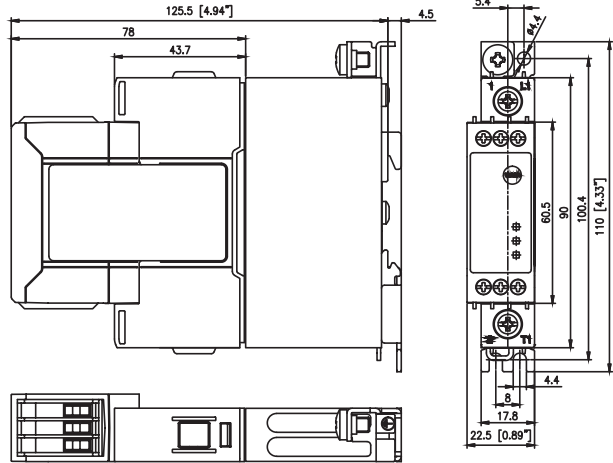

**RGC1S60D30GKEP , RGC1S60D31GKEP**

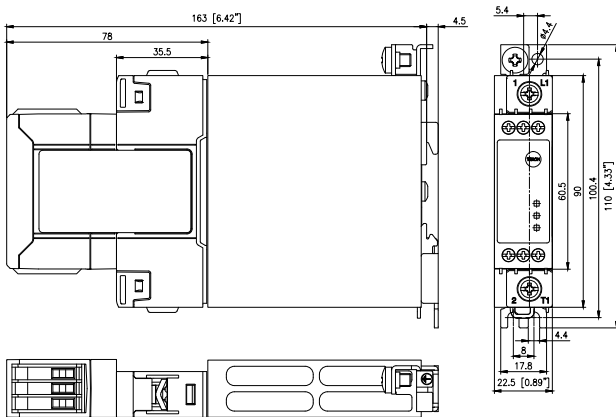

**RGC1S60D41GGEp**

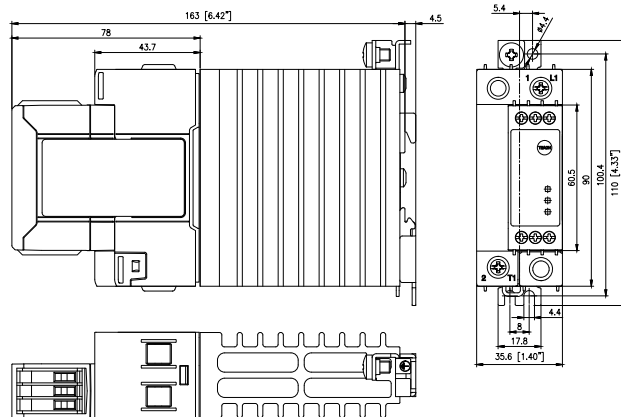

**RGC1S60D61GGEp**

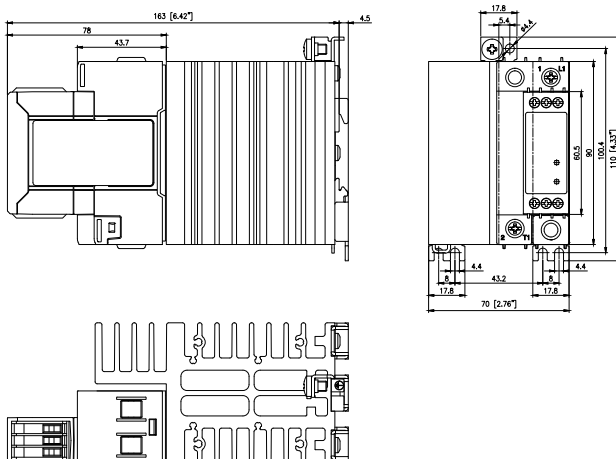

Housing width tolerance +0.5mm, -0mm as per DIN 43880. All other tolerances +/- 0.5mm. Dimensions in mm.

**Dimensions (cont.)**

**RGC1S60D90GGEP (fan to be supplied externally - no terminations provided on the RG module)**

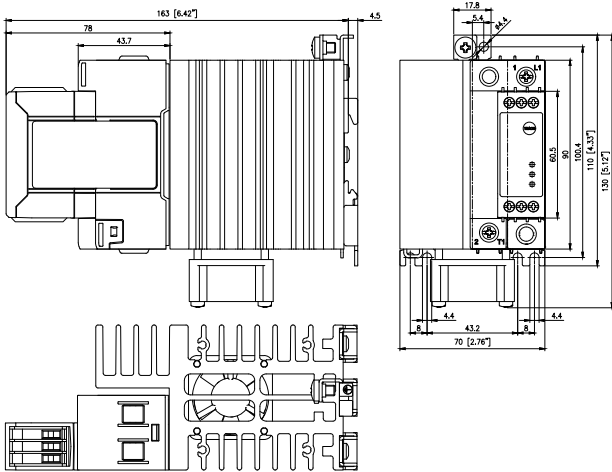

**RGC1S60D41GGUP**

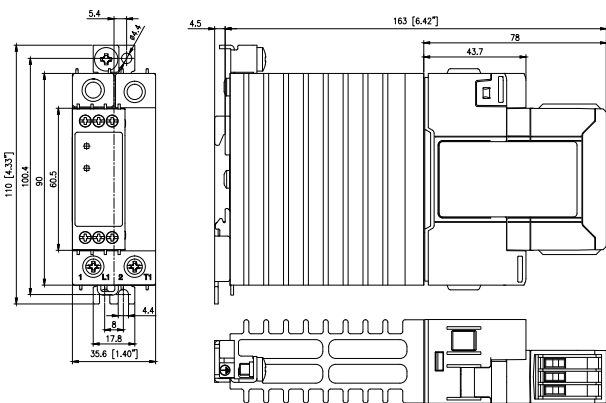

**RGC1S60D61GGUP**

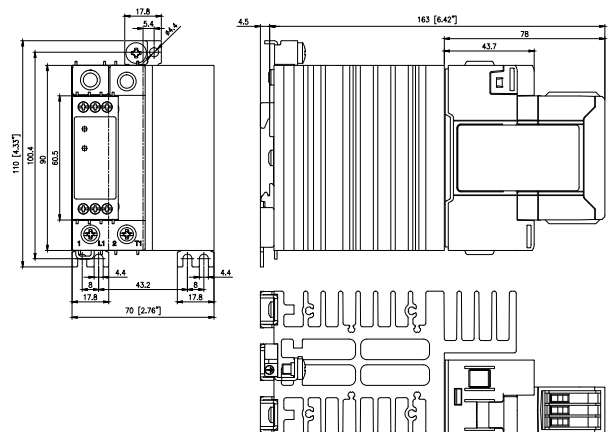

Housing width tolerance +0.5mm, -0mm as per DIN 43880. All other tolerances +/- 0.5mm.  
Dimensions in mm.

**Terminal interface**

RG...25GKEP  
RG...26GGEF  
RG...30GKEP  
RG...31GKEP

RG...41GGEP  
RG...61GGEP  
RG...90GGEP

RG...41GGUP  
RG...61GGUP

1 L1 : Line connection  
2 T1 : Load connection  
11+ : Alarm supply  
12- : Alarm output  
A1+ : Supply voltage  
A2- : Ground connection  
IN 1 : Remote TEACH signal  
IN 2 : Control voltage

Note:  
- Local TEACH by pressing front button for more than 3 seconds but less than 5 seconds  
- Fan supply (24 VDC) for RGC1A60D90GGEP has to be supplied directly to fan

**Connection interface**

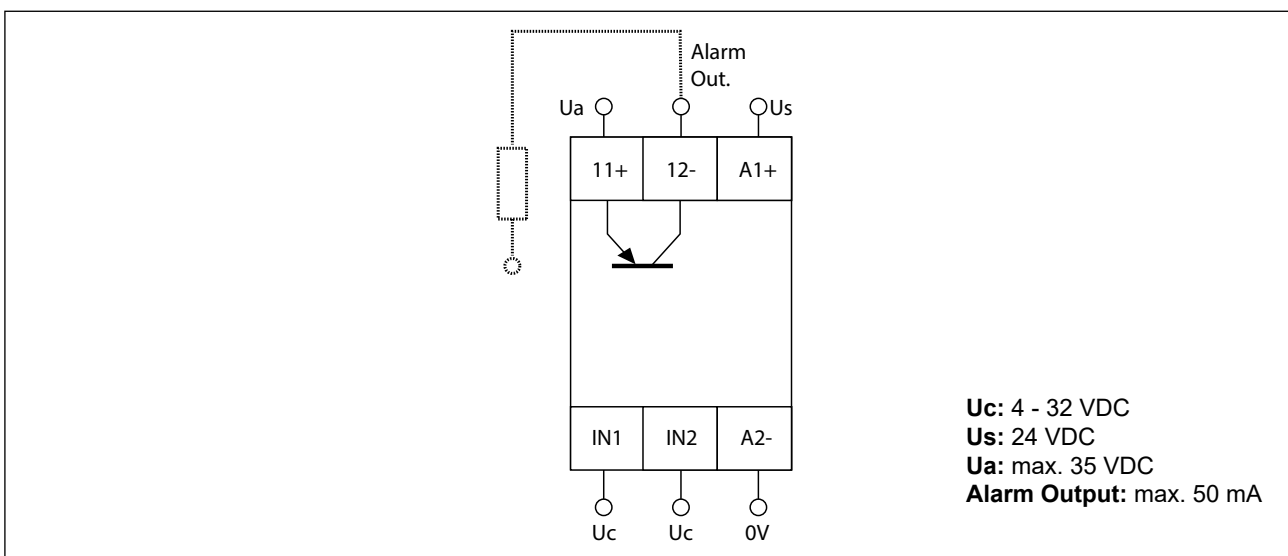

**Connection diagram for separate alarm outputs**

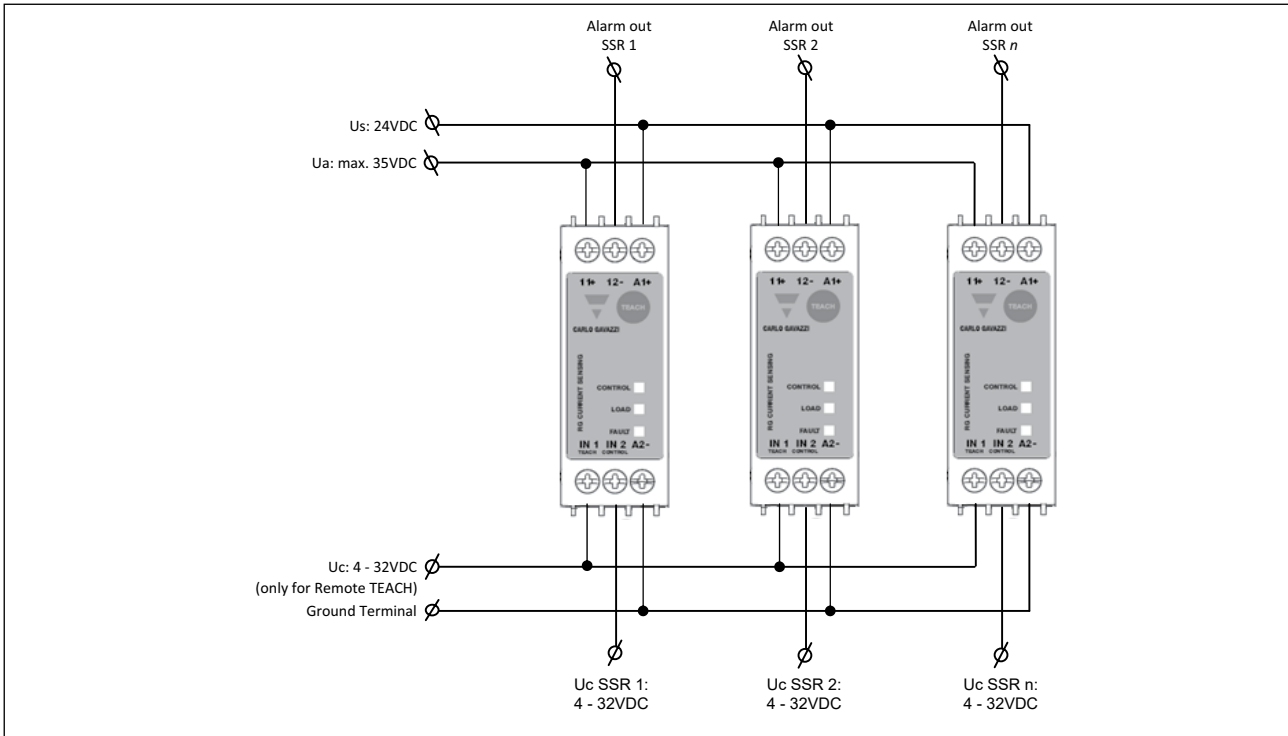

**Connection diagram for series alarm outputs**

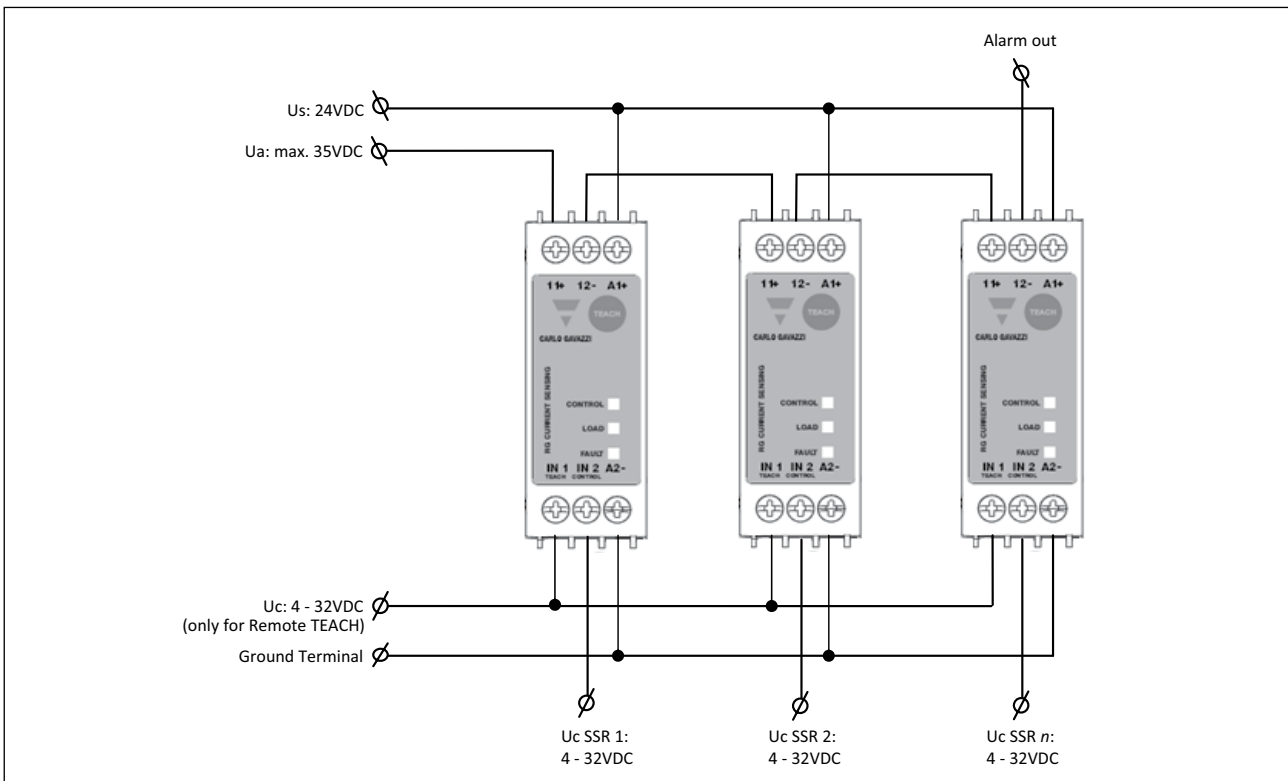

**Mounting instructions**

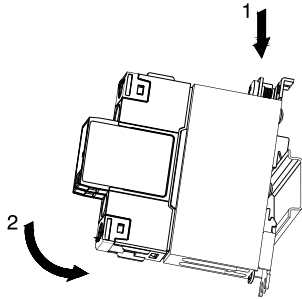

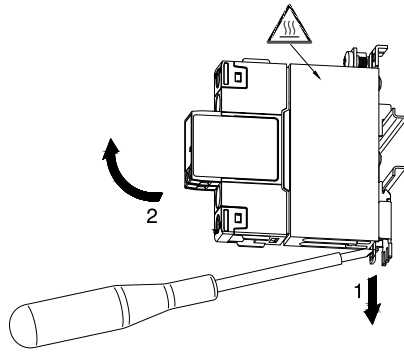

Mounting on DIN rail

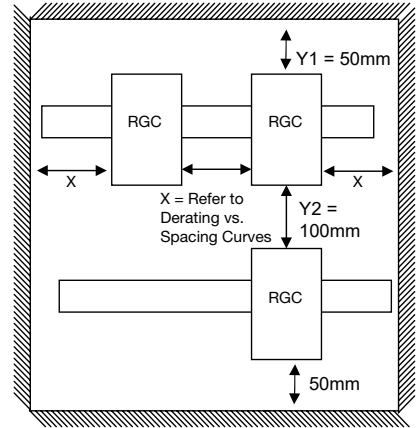

Dismounting from DIN rail

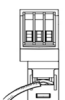

## Connection Specifications

Power connections			
Terminals	1/L1, 2/T1		
Conductors	Use 75°C copper (Cu) conductors		
	RGC1S..25GKEP RGC1S..30GKEP RGC1S..31GKEP	RGC1S..26GGEP	RGC1S..41GG.P RGC1S..61GG.P RGC1S..90GGEP
			
Connection type	M4 screw with captivated washer		M5 screw with box clamp
Stripping length	12 mm		11 mm
Rigid (solid & stranded) UL/cUL rated data	2x 2.5 – 6.0 mm <sup>2</sup> 2x 14 – 10 AWG	1x 2.5 – 6.0 mm <sup>2</sup> 1x 14 – 10 AWG	1x 2.5 – 25.0 mm <sup>2</sup> 1x 14 – 3 AWG
Flexible with end sleeve	2x 1.0 – 2.5 mm <sup>2</sup> 2x 2.5 – 4.0 mm <sup>2</sup> 2x 18 – 14 AWG 2x 14 – 12 AWG	1x 1.0 – 4.0 mm <sup>2</sup> 1x 18 – 12 AWG	1x 2.5 – 16.0 mm <sup>2</sup> 1x 14 – 6 AWG
Flexible without end sleeve	2x 1.0 – 2.5 mm <sup>2</sup> 2x 2.5 – 6.0 mm <sup>2</sup> 2x 18 – 14 AWG 2x 14 – 10 AWG	1x 1.0 – 6.0 mm <sup>2</sup> 1x 18 – 10 AWG	1x 4.0 – 25.0 mm <sup>2</sup> 1x 12 – 3 AWG
Torque specifications	Pozidriv 2 UL: 2.0 Nm (17.7 lb - in) IEC: 1.5 – 2.0 Nm (13.3 – 17.7 lb - in)		Pozidriv 2 UL: 2.5 Nm (22 lb - in) IEC: 2.5 – 3.0 Nm (22 – 26.6 lb - in)
Aperture for termination lug (fork or ring)	12.3 mm		n/a
Protective Earth (PE) connection	M5, 1.5 Nm (13.3 lb-in) M5 PE screw is not provided with the solid state relay. PE connection is required when product is intended to be used in Class 1 applications according to EN/IEC 61140		

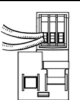
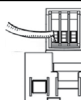
Control connections			
Terminals	A1(+), A2(-), IN1, IN2, 11 (+), 12(-)		
Conductors	Use 60/75°C copper (Cu) conductors		
			
Connection type	M3 screw with box clamp		
Stripping length	6 mm		
Rigid (solid & stranded) UL/cUL rated data	2 x 1.0 – 2.5 mm <sup>2</sup> 2 x 18 – 14 AWG	1 x 1.0 – 2.5 mm <sup>2</sup> 1 x 18 – 14 AWG	
Flexible with end sleeve	2 x 1.0 – 2.5 mm <sup>2</sup> 2 x 18 – 14 AWG	1 x 1.0 – 2.5 mm <sup>2</sup> 1 x 18 – 14AWG	
Torque specification	Pozidriv 1 UL: 0.5 Nm (4.4 lb - in) IEC: 0.4 - 0.5 Nm (3.5 - 4.4 lb - in)		



COPYRIGHT ©2025  
 Content subject to change.  
 Download the PDF: <https://gavazziautomation.com>