

AC/DC Input Solid State Relay

PCS15



FEATURES

- 10 A to 40 A Output
- **DC Input:** 3-32 VDC, or **AC Input:** 24, 110 or 220 VAC
- Panel Mount
- Built in Snubber
- Dielectric Strength of 4,000 VAC
- Optical Isolation Between Input and Output
- Encapsulated, Thermally Conductive Epoxy
- RoHS Compliant

INPUT PARAMETERS (Ta = 35°C) US E93379

Control Voltage Range (DC Input)	3 - 32 VDC (Without LED)
	4 - 32 VDC (With LED)
Control Voltage Range (AC Input)	85 - 132 VAC (110 VAC Input)
	175 - 264 VAC (220 VAC Input)
	19.2 - 28.8 VAC (24 VAC Input)
Must Turn-On Voltage (DC Input)	3 VDC (Without LED)
	4 VDC (With LED)
Must Turn-On Voltage (AC Input)	85 VAC (110 VAC Input)
	175 VAC (220 VAC Input)
	19.2 VAC (24 VAC Input)
Must Turn-Off Voltage (DC Input)	1 VDC
Must Turn-Off Voltage (AC Input)	10 VAC (110 V, 220 V Input)
	2 VAC (24 V Input)
Max. Input Current	25 mA (DC)
	15 mA (AC)
Max Reverse Protection Voltage (DC Input)	- 32 VDC

CROSS REFERENCES

Crouzet: GNA5
Example: 84134914 Crosses to PCS15-D-240A-25ZL
Crydom: CL
Example: CL240D10 Crosses to PCS15-D-240A-10ZL
Opto 22: AC Series
Example: 240D3 Crosses to PCS15-D-240A-10Z

OUTPUT PARAMETERS (Ta = 35°C)

Load Voltage Range	240 A	48 - 280 VAC			
	380 A	48 - 440 VAC			
Max. Transient Voltage	240 A	600 Vpk			
	380 A	800 Vpk			
Load Current (Amps)	10A	15A	20A	25A	40A
Load Current Range (Amps)	0.1 - 10	0.1 - 15	0.1 - 20	0.1 - 25	0.1 - 40
Max. I ² t (10 ms, A ² s)	78	144	312	312	880
Max. Surge Current (10 ms)	100 Apk	150 Apk	200 Apk	250 Apk	400 Apk
Max. Off-State Leakage	10 mA				
Max. On-State Voltage	1.5 VRMS				
Max. Turn-On Time (DC Input)	Zero –Cross: 1/2 Cycles + 1 ms; Random: 1 ms				
Max. Turn-On Time (AC Input)	30 ms				
Min. Off-State dv/dt	200 V/us				
Min. Power Factor	0.5				

CHARACTERISTICS

Dielectric Strength	2,500 VAC, 50 Hz/60 Hz, 1 min, Input, Output to Base
	4,000 VAC, 50 Hz/60 Hz, 1 min, Input to Output
Insulation Resistance	1,000 MΩ at 500 VDC
Operating Temperature	- 30°C to 80°C
Storage Temperature	- 30°C to 100°C
Weight	70 g

ORDERING INFORMATION

Example:	PCS15	-D	-240A	-10	Z	L
Model:	PCS15					
Control Voltage:	D: 3-32 VDC (Without LED), 4-32 VDC (With LED); 24A: 19.2 - 28.8 VAC; 110A: 85 - 132 VAC; 220A: 175 - 264 VAC					
Load Voltage:	240A: 48-280 VAC; 380A: 48-440 VAC					
Load Current:	10: 10 A; 15: 15 A; 20: 20 A; 25: 25 A; 40: 40 A					
Switching Type:	Z: Zero Crossing; R: Random Turn-On					
Over Voltage Protection:	Nil: None; Y: With Varistor (MOV)					
Status LED:	Nil: Not Included; L: Indicator LED					
Terminal Type:	Nil: Screw Terminal; Q: Quick Connect (1/4" Control, 3/8" Power)					

For Accessories and Heat Sinks see page 3

470V/φ10 is a 470 Volt Nominal, 20 mm Diameter MOV

Box Quantity: 100; Inner Box: 2

PRECAUTIONS

- 1) When choosing a Solid State Relay (SSR), note the actual load current and ambient temperature and reference the Characteristic Curves below.
- 2) SSRs require a adequate heat sinking or other effective cooling measures.
- 3) With ambient temperature above 25°C refer to the curve of Max. Load Current vs Ambient Temperature for load current derating.
- 4) Apply heat-conducting silicon grease or a thermal transfer pad on the space between SSR and heat sink and screw the SCR firmly in to the heat sink to avoid damage from overheating.
- 5) Tighten the SSR terminal screws properly. We recommended screw installation torque as follows :
 M4 screw mounting torque range is (0.98-1.37)N • m,
 M3 screw mounting torque range is (0.56-0.98)N • m.
 Lose screws will damage the SSR with heat generated from connections. Also, excessive screw torque may damage relays internal components.
- 6) It is recommended to use a heat sink matched to the Current Load. With any heat sink test that the SSR base temperature does not exceed 65°C.
- 7) When using the PCS15 relay with an inductive load, it is suggested to select random turn-on (i.e., a model with "R" letter).
- 8) The PCS15 is not suitable for capacitive loads; if you must then do not choose products with varistor protection (i.e., a model with "Y" letter).
- 9) Listed parameters are based on resistive loads. Do not use the relay beyond the described current, temperature, load or voltage limits as described in this data sheet.

DIMENSIONS (mm)

SCREW TERMINAL

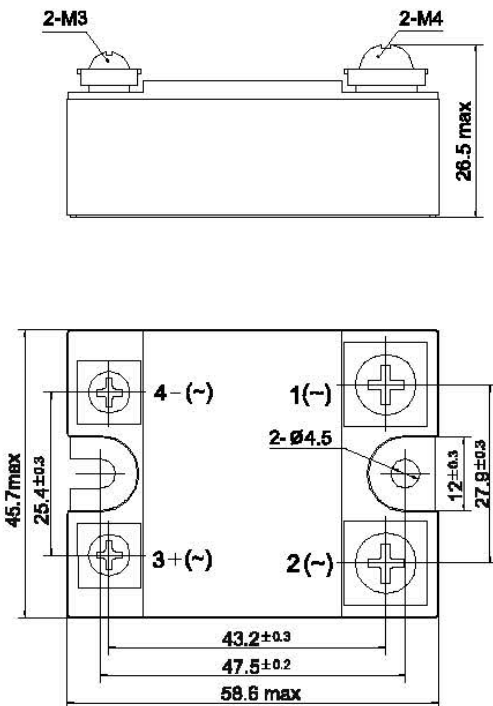

QUICK CONNECT

2 - 4.75 mm x 0.8 mm Faston Terminal 2 - 6.35 mm x 0.8 mm Faston Terminal

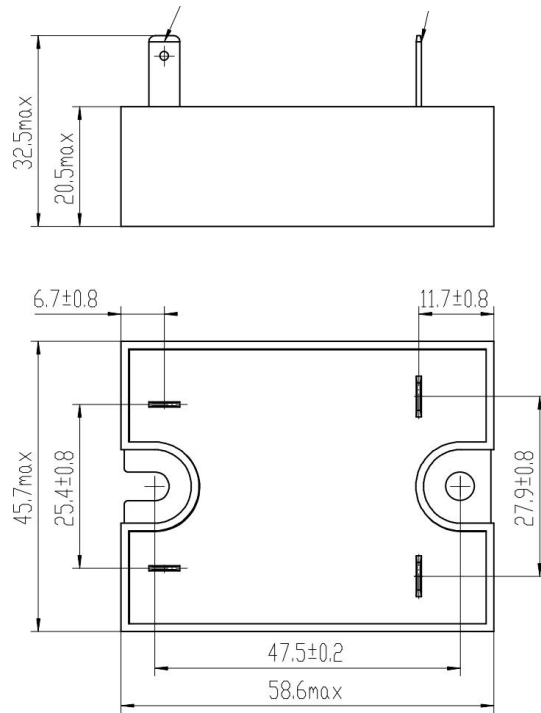

Mounting Holes

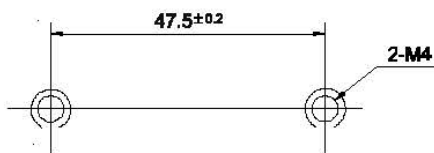

Wiring Diagram

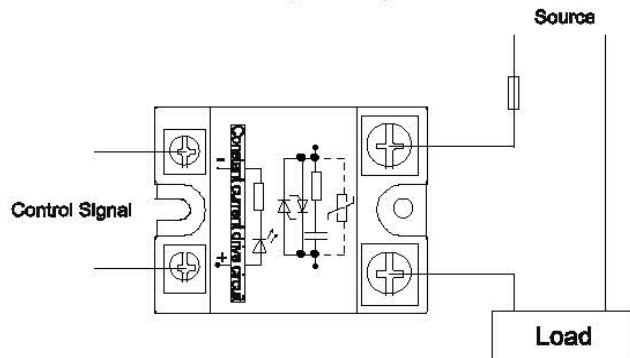

ACCESSORIES

Heat Transfer Pad	HTP100
Protective Cover	SSR100
Heat Sinks	PCH-I-50 for applications up to 20 Amps @ 25°C Ambient Temperature
	PCH-H-110 for applications up to 35 Amps @ 25°C Ambient Temperature
	PCH-H-150 for applications up to 40 Amps @ 25°C Ambient Temperature

ACCESSORIES SOLD SEPERATELY

CHARACTERISTIC CURVES

