

## Terminal Block, Double Row **621 RZ XX**

Replace "XX" with 01 through 30 for number of poles.  
7/16 (.438) Pitch



### Wire Range

- Standard (binding) screw #14 - #22 AWG copper only, torque 9 lb-in
- Listed lug (crimp type ring, spade, or fork terminal), #10-22 AWG, torque 9 lb-in
- 3765 (SEMS) screw options, #12 - #22 AWG copper only, torque 12 lb-in
- PSB screw option, #14 - #22 AWG copper only, torque 9 lb-in

### Electrical Ratings

- Amps
  - 20A with unprepared bare wire
  - 30A with listed lug (with crimp type ring, spade, or fork terminal)
- Voltage
  - 600 Volts AC/DC (UL 1059 Class C, Use Group – General Industrial)
- Short Circuit Current Rating: 10,000A (Default)
- Approved for Factory and Field Wiring.

### Agency Compliance









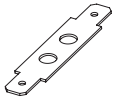

- UL Recognized, UL 1059 Terminal Block Standard, File No. XCFR2.E62806
- CSA Certified, CSA C22.2 No. 158, File No. LR19766
- CE compliant, IEC 60947-7-1
- RoHS Compliant

### Material Information

- Insulator base:
  - Thermoplastic
  - Flammability rating of insulator base UL94V0
  - Insulator base temperature rating: -40°C to 125C (UL RTI)
- Connector - Brass, tin plated
- Drive screw (Rivet): Stainless steel
- Screw, #6-32 Binder head, Phil-Slot: Steel, nickel plated

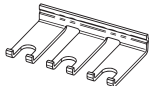
# Product Data Sheet

## Hardware Options

Catalog #	Product Description	Images	
KT37	Full Quick Connect (0° Flat)		<a href="#">Reference</a>
KT38	Full Quick Connect (45° Flat)		
KT39	Full Quick Connect (90° Flat)		
KT43	Half Quick Connect (0° Flat)		
KT44	Half Quick Connect (45° Flat)		
KT45	Half Quick Connect (90° Flat)		
ST	Full Solder	No Image	<a href="#">Reference</a>
3/4 ST	Half Solder	No Image	
J 621	Line-to-Line Jumper		<a href="#">Reference</a>
601RJ(S)	Multiple Position Jumper		
3765	SEMS Pressure Saddle Screw		<a href="#">Reference</a>
3767	SEMS Pressure Saddle Screw with external tooth lock washer		
PSB	Phil-Slot Brass Screw	--	--
	Covers - Top Mounted		<a href="#">Reference</a>
	Making & Insulator Strips - Sub-Mounted		<a href="#">Reference</a>
	Marking Strips - Top Mounted		<a href="#">Reference</a>

# Product Data Sheet

## Drawing

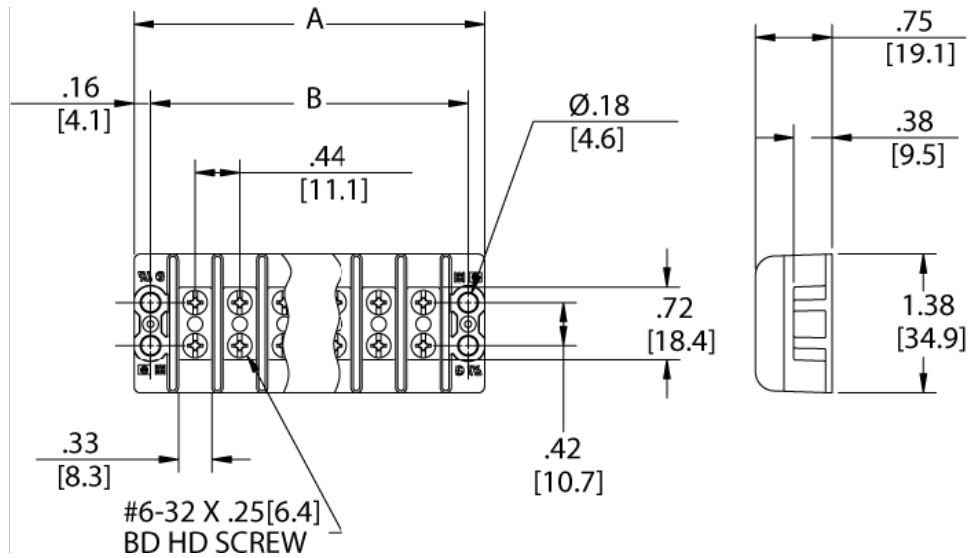

## Mounting:

- #6 Fastener Mounting torque to be determined in end use application not to exceed 15 lb-in (1.7 Nm)

Dimensions			
Catalog #	# of Poles	A	B
621 RZ 01	1	1.19	0.88
621 RZ 02	2	1.62	1.31
621 RZ 03	3	2.06	1.75
621 RZ 04	4	2.50	2.19
621 RZ 05	5	2.94	2.63
621 RZ 06	6	3.37	3.06
621 RZ 07	7	3.81	3.50
621 RZ 08	8	4.25	3.94
621 RZ 09	9	4.68	4.37
621 RZ 10	10	5.12	4.81
621 RZ 11	11	5.56	5.25
621 RZ 12	12	5.99	5.68
621 RZ 13	13	6.43	6.12
621 RZ 14	14	6.87	6.56
621 RZ 15	15	7.31	7.00
621 RZ 16	16	7.75	7.44
621 RZ 17	17	8.19	7.88
621 RZ 18	18	8.62	8.31

Dimensions			
Catalog #	# of Poles	A	B
621 RZ 19	19	9.06	8.75
621 RZ 20	20	9.50	9.19
621 RZ 21	21	9.93	9.62
621 RZ 22	22	10.37	10.06
621 RZ 23	23	10.81	10.50
621 RZ 24	24	11.24	10.93
621 RZ 25	25	11.68	11.37
621 RZ 26	26	12.12	11.81
621 RZ 27	27	12.55	12.24
621 RZ 28	28	12.99	12.68
621 RZ 29	29	13.43	13.12
621 RZ 30	30	13.86	13.15