



Solutions

Renewable Energy

Renewable Energy

Solutions for

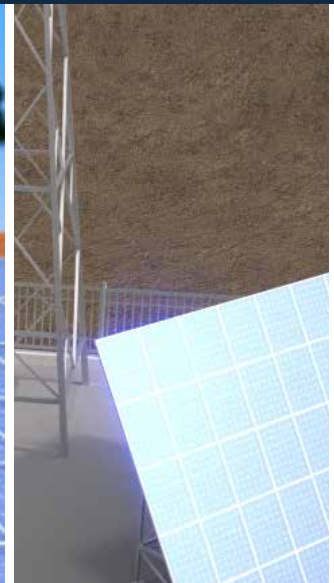

Photovoltaic parks

Photovoltaic small business, commercial and tracking systems

Photovoltaic residential systems

Off-grid systems

ABOUT CARLO GAVAZZI

Carlo Gavazzi Automation is an international group active in designing, manufacturing and marketing electronic equipment targeted at the global markets of industrial and building automation.

Our history is full of firsts and our products are installed in a huge number of applications all over the world. With more than 80 years of successful operation, our experience is unparalleled.

We have our headquarters in Europe and numerous offices around the world.

Our R&D competence centres and production sites are located in Denmark, Italy, Lithuania, Malta and the People's Republic of China.

We operate worldwide through 22 of our own sales companies and also selected representatives in more than 65 countries, from the United States in the West to the Pacific Rim in the East.

Our core competence in automation spans three product lines: Sensors, Switches and Controls.

Our wide array of products includes sensors, monitoring relays, timers, energy management system, solid state relays, safety devices and fieldbus systems.

We focus our expertise on offering state-of-the-art product solutions in selected market segments.

Our customers include original equipment manufacturers of packaging machines, plastic injection moulding machines, food and beverage production machines, conveying and material handling equipment, door and entrance control systems, lifts and escalators, as well as heating, ventilation and airconditioning devices.



DESIGNED TO MEET MARKET REQUIREMENTS

The increasing demand for energy, the availability and cost of oil and issues of pollution make alternative sources of renewable energy essential.

Sun and wind energy can be transformed into electricity that can be used directly or fed into the grid according to national regulations.

Renewable energy, in combination with energy efficiency, is the basis for sustainable development and respect for the environment in which we all live.

Carlo Gavazzi's wide expertise is focused on developing and offering

a package of products and devices for the Renewable Energy market, specifically photovoltaic power plants.

The growing development of cost effective solar energy technology has great potential to benefit our world. Solar technologies diversify the energy supply, reduce our dependence on fossil fuels, improve air quality and offset greenhouse gas emissions.

Carlo Gavazzi offers complete and modular solutions to monitor and control the efficiency of photovoltaic plants.

Our PV monitoring solution consists of Eos-Array, Eos-Web devices, depending upon the requirements and

complexity of the photovoltaic plant.

The Eos-Array and Eos-Array Lite are modular systems, providing efficient local string control to the PV plant.

The Eos-Web is a web-server suitable for controlling and supervising small to medium installations as a stand-alone solution.

Renewable Energy

Photovoltaic parks

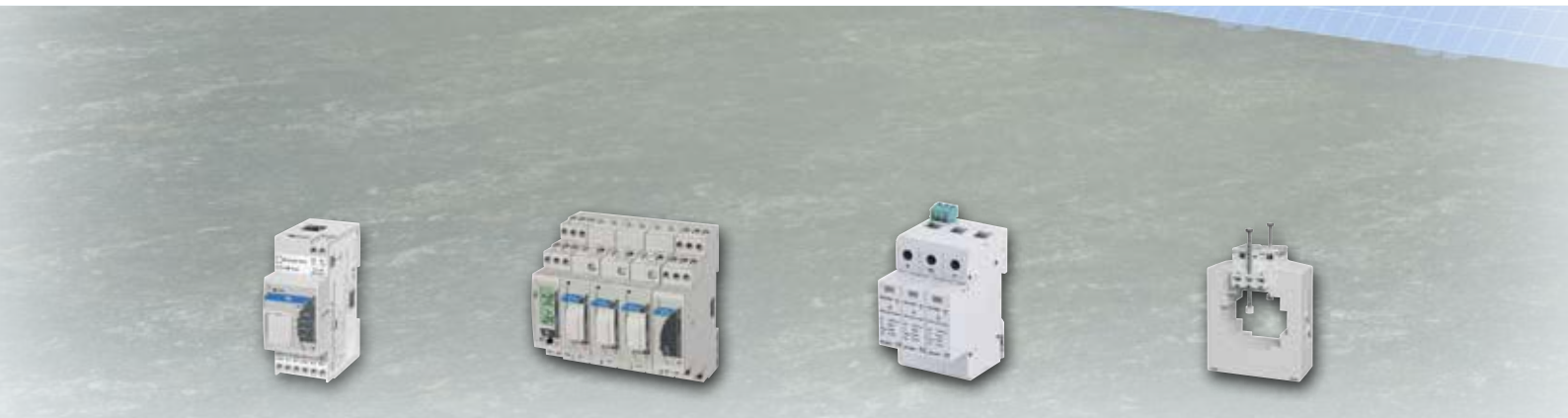
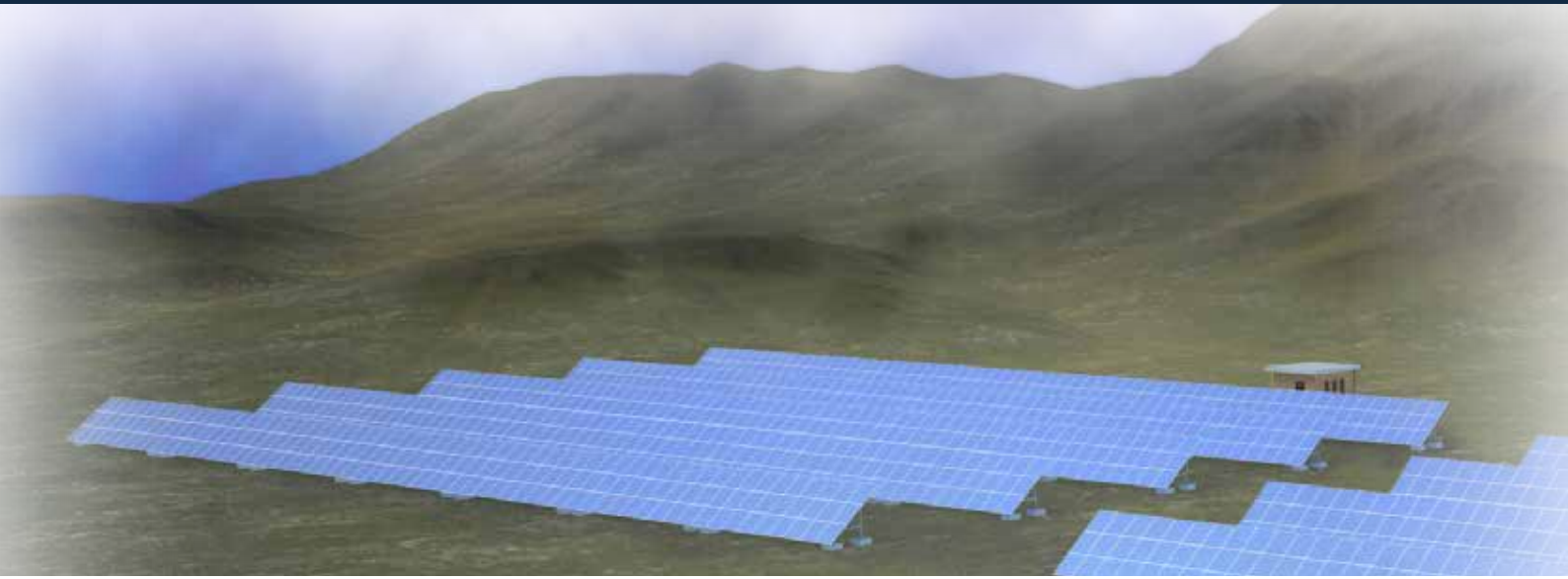

**Web servers
and dataloggers**

**Solar monitoring
solutions**

**Surge
protecting devices**

**Current
transformers**

VMU-C PV

Eos-Array

**DSF
DSB
DSC**

**CTD
TADK**

In terms of scale and accessibility, solar parks represent the most economical option as regards planning and construction. Carlo Gavazzi products ensure an important contribution to the maximum capacity utilization of the solar electricity produced in photovoltaic power plants - both fixed

plants or plants with tracking systems, with 1 or 2 axes.

To complement photovoltaic modules, Carlo Gavazzi provides many components for a photovoltaic installation, especially for surge protection and plant monitoring.

Systems and devices to monitor and

control the efficiency of photovoltaic parks are essential to ensure that the solar investment is a solid and efficient one. The Eos-Web is the ideal solution for installations up to 1 MW.

The Eos-Web is a web server gathering data from string monitoring units such as the Eos-Array, inverters and



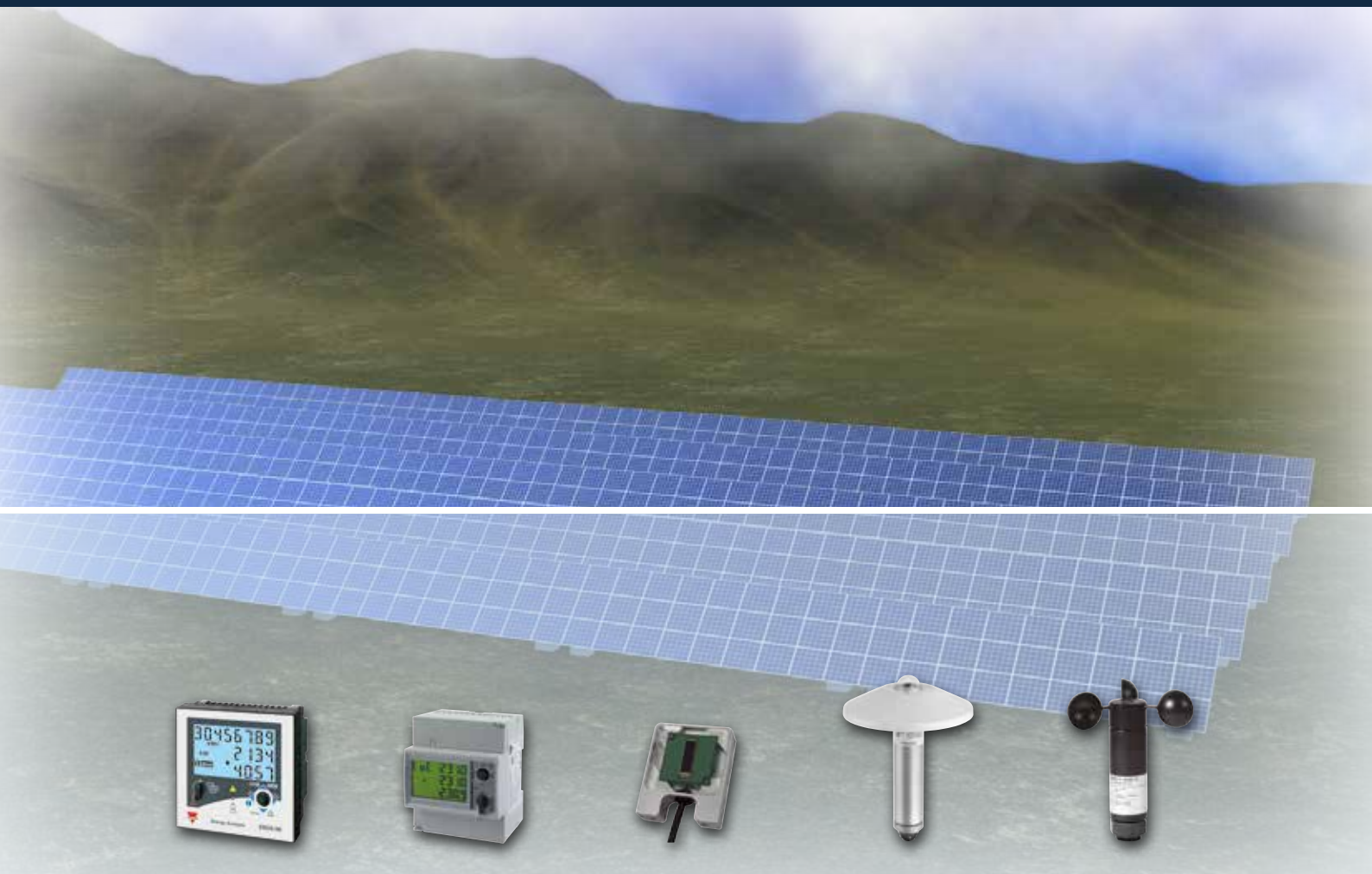

**3-phase
energy analyzers**

**EM26
EM24**

**Interface
protections**

PI-DIN

**Environmental
sensors**

**PVS-1
TEMPSOL
IKE2000**

Pyranometers

PVS-2A

**Anemometers
Wind vanes**

**DWS-V
DWS-D**

energy meters. All plant information is available simply by using the PC web browser and any Internet connection. The Eos-Array is a comprehensive string control system, suitable for being integrated into both Eos-Web based solutions and standard SCADA software packages.

Based on glass optical fibre, the SIUFO is the solution for reliable communication where a traditional RS485 network cannot guarantee the correct level of immunity from electromagnetic emissions from inverters, substations or power wiring. Carlo Gavazzi's flexible and modular

PV monitoring architecture allows all the needs of investors, PV plant installers and maintenance services to be satisfied. Carlo Gavazzi application engineers and product specialists with solid expertise provide complete support, starting from project planning up to start up.



Renewable Energy

Photovoltaic small business, commercial and tracking



Surge protecting devices

**DSF
DSB
DSC**



Solar monitoring solutions

Eos-Array



Web server modules

**VMU-C PV
VMU-D**



Current transformers

**CTD
TADK**

Carlo Gavazzi provides everything for PV plant monitoring.

Eos-Array and Eos-Array Lite are systems composed of individual modular elements interacting with one another, providing efficient local control to the solar plant and ensuring effective information management in medium or high power plants.

Carlo Gavazzi provides the Eos-Web, where the VMU-C unit is a local web-based data management system which gathers measurements and status information from one or more inverters to your PC or to a centralised cloud monitoring solution based on the Eos-Server. With some rented roofs, wired internet is not available, but VMU-D

solves this problem by using diffuse mobile communication.

Carlo Gavazzi energy meters and analyzers measure the energy produced and provided to the grid or locally consumed.

These meters can be supplied with MID certification (Annex D).

The energy produced at low voltage by a PV plant can be measured with a MID approved meter such as the EM210, EM24 or EM26.

When supplying energy to the grid, it is necessary to use a protection device installed between the generator and the power grid in order to grant the required voltage and/or frequency control.

Carlo Gavazzi's interface protections

are the most compact solutions currently available on the market.

The PI-DIN protection adds a control function to frequency derivative and event recording and is equipped with a large display for local information readout and a serial port for remote readout.

The surge protecting devices for direct and indirect lightning discharge complete the Carlo Gavazzi portfolio for the photovoltaic market.

The range includes surge protection devices for the protection of DC lines up to 1200 VDC, the mains AC lines and also the serial communication devices.



3-phase energy analyzers

**EM271 / EM210
EM24 / EM26**



Interface protections

PI-DIN



Environmental sensors

**PVS-1
PVS-2A
TEMPSOL**



Contactless power analyzers

**CPA300-V
CPA300
CPA050**

Energy storage systems

PV energy is generated during the day, while the user generally consumes it during the evening. To minimise the flow between the plant and the grid, it is worth having an energy storage system on site.

In order to evaluate the amount of energy going through the battery system compared to the quantity sent to the grid, it is necessary to measure the flow in both these 2 directions. The information gathered allows the evaluation of the efficiency and payback of the system, but it is also useful to know the charging status of the battery pack.

Carlo Gavazzi offers two solutions for

the energy storage systems for new plants and for retrofitted.

The CPA is the ideal solution for new renewable energy plants and storage systems, thanks to its smart mounting system and a comprehensive set of measurable variables, such as voltage, power, energy, frequency, power factor and THD, available through RS485/Modbus communication.

The EM271 and the relevant TCDxM split core current sensing units are frequently used in energy storage systems both new and retrofitted.

The EM271 is able to measure 2 loads in a single meter, allowing for time and space savings.



Renewable Energy

Photovoltaic residential systems



Solar monitoring solutions

Eos-Array Lite

Web server modules

VMU-C PV

1-phase energy meters

**EM111
EM112**

3-phase energy analyzers

**EM340 / EM330
EM271 / EM210
EM24**

Touch screens / Data loggers

SmartHUB

PV plants in residential areas are mostly grid connected installations.

Modules are set on roofs and the energy produced by the PV modules is delivered to the inverters and then fed into the public grid. Carlo Gavazzi offers a wide range of devices and components for the configuration of the electrical solar plant. Separate interface protection can be achieved with our wide range of monitoring relays such as the PI-DIN, DPC and DPC02, according to national norm requirements.

For energy metering you can use the EM1xx single-phase energy meter series or the EM2xx and EM3xx series for 3-phase PV residential system applications, all with LCD data display.

The real-time energy usage measurements, made via our touch screen and data logger SmartHUB, will lead to more efficiency in energy consumption needs, resulting in significant energy savings. The system reads and logs the energy consumption of the whole installation or of a single load. Data can be accessed anytime by means of a web-server/web-app and shown as instantaneous values, or in the form of graphs and/or diagrams.

For protection against surges and overvoltages it is possible to use the DSB or DSF surge arresters for both DC and AC lines. In the case of direct lightning discharge protection, the DSC series can be used.



Off-grid systems

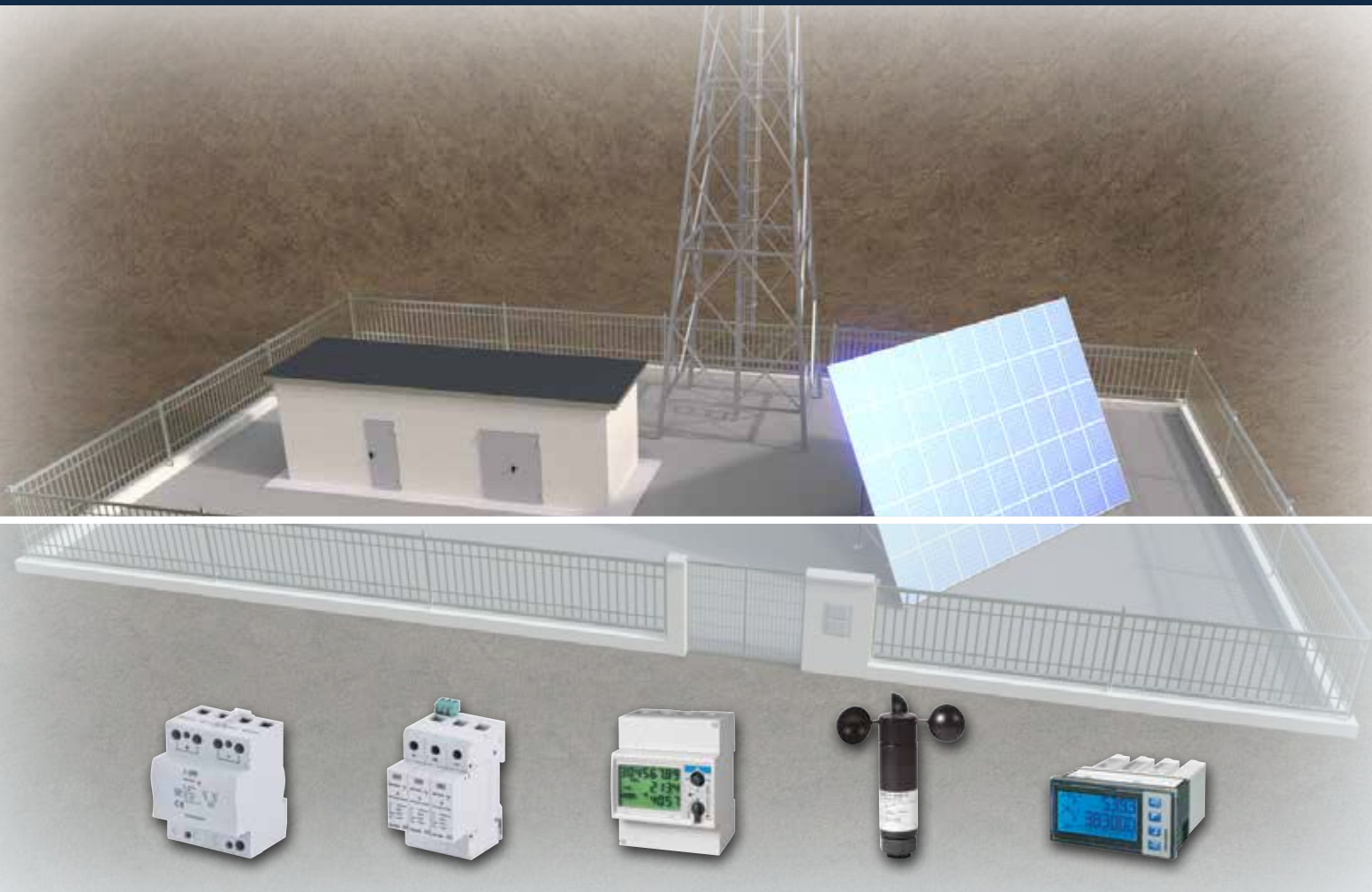

Surge protecting devices

DSC

Surge protecting devices

**DSB
DSF**

3-phase energy analyzers

**EM24
EM210
EM330/EM340**

**Anemometers
Wind vanes**

**DWS-V
DWS-D**

Digital modular indicators

UDM60



In remote areas renewable energy systems are gaining popularity, using stand-alone, off-grid plants with or without battery storage.

Carlo Gavazzi provides some additional components that can play an important role in such installations. DSC surge protecting devices provide protection for PV installations where an LPS (Lightning Protection System) is installed, hence subject to direct lightning strikes. This device is Type 1 and Type 2 approved.

DSB and DSF surge protecting devices can be used either on wind turbines or on PV installations. They are available for DC and AC networks and are Type 2, suitable for indirect lightning

protection. Wind speed and direction are extremely important parameters. Accurate measurements are necessary to keep the wind turbine structure under control. The Carlo Gavazzi anemometer DWS-V, with opto electronic detection, measures speed from 2 to 30 m/s. The sensor is designed with a dust and humidity seal, which makes the sensor impervious to all weather conditions. The micro-processor-based digital panel meter (UDM60), with its dual 6-dgt LCD indicator, displays the wind speed by measuring the input from the anemometer, while the energy produced is measured by a 3-phase energy analyzer (EM24, EM210, EM330 or EM340).

Renewable Energy

The diagrams

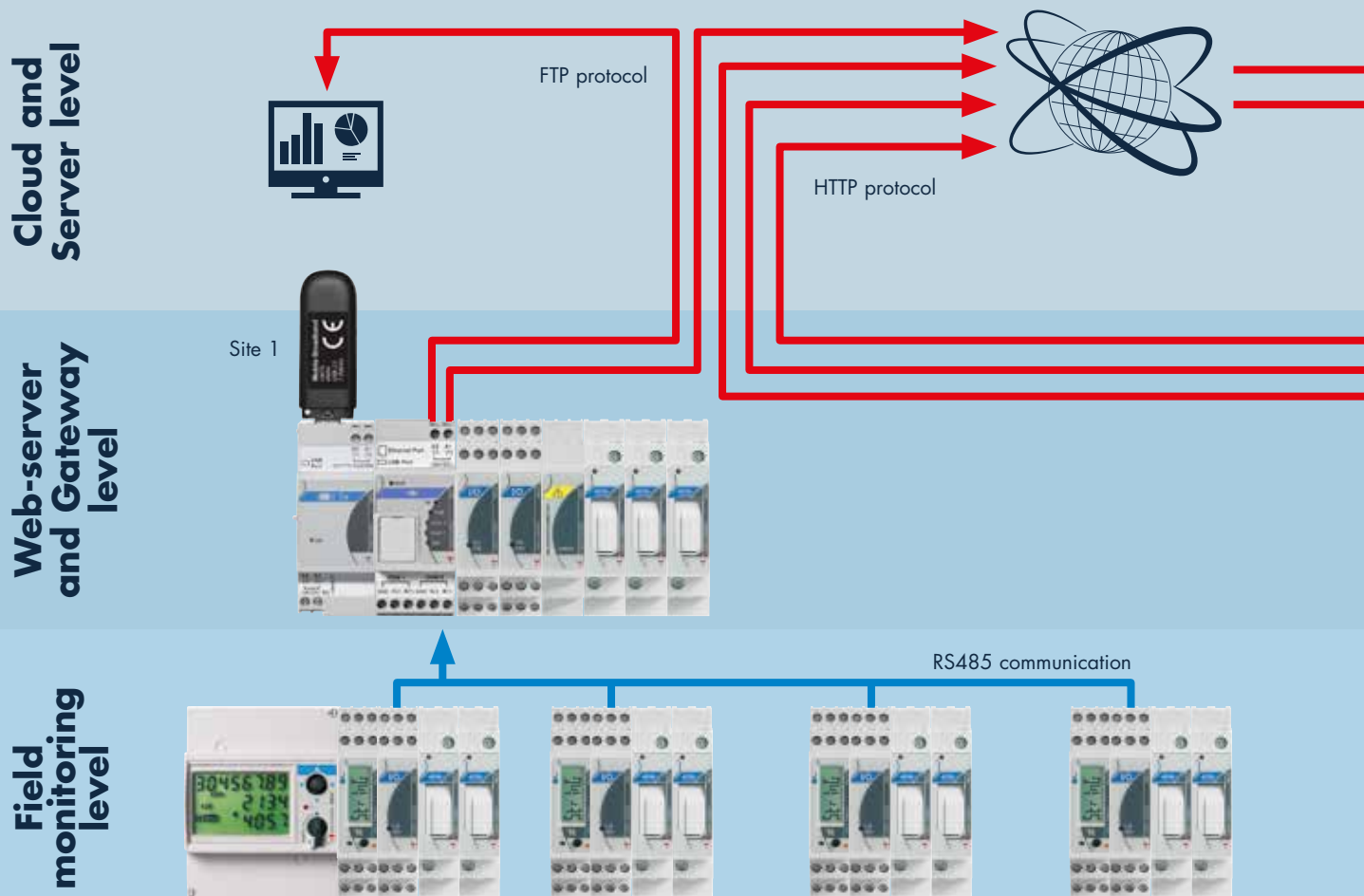

VMU-C PV into a photovoltaic monitoring architecture

The VMU-C PV is the core solution for effective Photovoltaic Monitoring in applications of all sizes.

It collects measurements from Eos-Array string control units, energy meters and inverters; it stores information (variables and alarms) in its local database and displays it through its web-based graphical user interface.

The whole system set-up and operation is possible via the VMU-C's web interface, without any external software. The VMU-C PV can exchange data with other systems by means of standard FTP/HTTP communication.



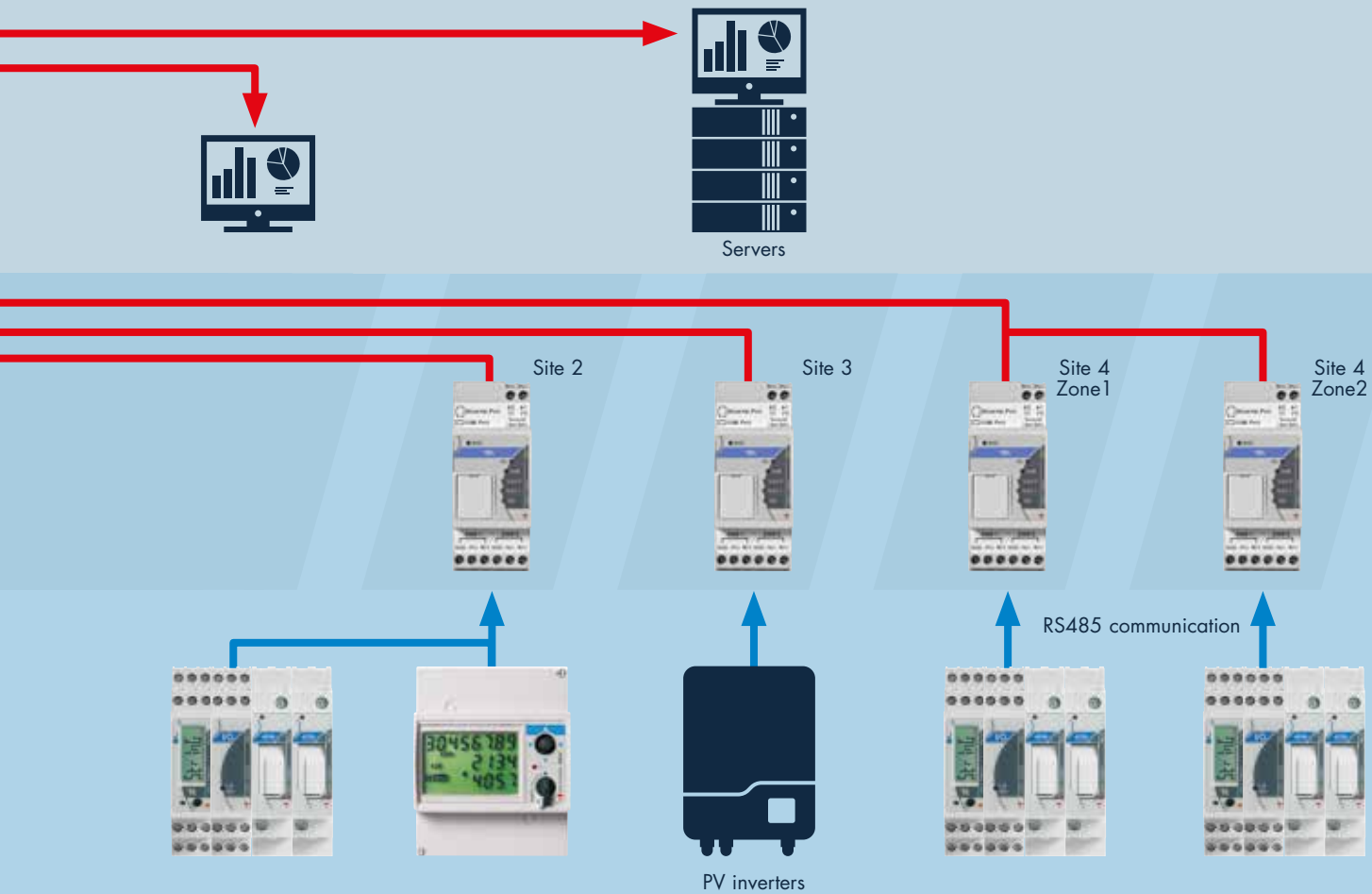

VMU-C PV's benefits at a glance

- No crash or compatibility problems due to different operative systems, different languages, libraries, etc.
- Improved IT security
- On-site database
- Application-focused software embedded inside industrial grade hardware: no need for a dedicated PC for monitoring
- Modular solution for additional inputs/outputs
- Polling device, data-logger and Ethernet gateway in a single compact unit
- Optional modular modem for wireless Ethernet connections



Renewable Energy

Our product range

Solar monitoring solutions



Eos-Array / Eos-Array Lite

- Modular local monitoring system for PV plant
- Up to 16 DIN module configuration
- Eos-ArraySoft, freeware configuration software
- Eos-Array can manage in addition to VMU-M unit up to: 1 VMU-P, up to 15 VMU-S and up to 7 VMU-O for a total of maximum 15 units

MAIN FEATURES

- The Eos-Array solution can be composed of: VMU-M master unit and data logger; VMU-S string controller; VMU-P environment variable unit and VMU-O I/O unit
- Eos-Array Lite is the answer to those photovoltaic applications where a less sophisticated monitoring solution is needed

Web servers and dataloggers



VMU-C PV (Eos-Web)

- Dimensions: 2 DIN modules
- Micro PC with web server and web service capability
- Data and event logging capability
- Internal 4GB memory and 16GB SDHC card back-up memory (on request)
- Variables shown as graphs and numbers in formatted tables
- All data exports on HTML format
- Management up to 14 Eos-Array, 64 inverters + energy meters

MAIN FEATURES

- Efficiency calculation and control on different levels: string, BOS and Performance ratio and Yield indices
- Alarms control with automatic e-mailing and SMS management by means of VMU-D

USB dongle connection modules



VMU-D

- Dimensions: 2 DIN modules
- Compatible with Carlo Gavazzi approved 3G/4G USB modems
- Power supply: 24 VDC (+/- 20%)
- Suitable for use with VMU-C

MAIN FEATURES

- 3G or 4G Mobile Internet connectivity
- SMS alerting
- SMS commands

Touch screens / Data loggers



SmartHUB

- Energy data logging from meters and PV inverters
- Colour touch screen 7" (BTM-T7) and 4.3" (BTM-T4)
- Remote access through web browsers
- Alarms management

MAIN FEATURES

- Wide screen display, 64 K colours
- 2 Ethernet port with integrated switch
- SD memory card slot
- USB host port
- Multistandard Modbus RTU serial communication port (selectable: RS485, RS422 or RS232)

1-phase energy analyzers



EM111 / EM112

- Dimensions: 1 DIN module (EM111) 2 DIN modules (EM112)
- Backlit touch LCD
- Measurement of voltage, current, power, power factor and frequency
- Measuring inputs: 120 VAC, 230 VAC, 32 A (max 45 A) (EM111)/100 A (EM112)
- Bi-directional energy metering, 7 digits (EM111) 8 digits (EM112), Class B (EN50470)

MAIN FEATURES

- Self-powered
- Pulse output or as an alternative: RS485 Modbus, M-Bus
- Sealable terminal covers
- MID Annex D certification available (230 V) CE, UL (120 V)

3-phase energy analyzers



EM26

- Dimensions: 96 x 96 mm housing, only 45 mm behind the panel
- 3-phase energy meters with CT/VT connection
- Primary current input: 5 A
- Class 1 (kWh) according to EN62053-1 Class B (kWh) according to EN50470
- Modbus communication port

MAIN FEATURES

- Energy analyser in a very compact housing to save space
- Suitable for measuring generated and consumed energy
- MID Annex D certification available

3-phase energy analyzers



EM24

- Dimensions: 4 DIN modules
- 3-phase energy analyzers with direct connection or by CT
- Current input for direct connection up to 65 A or external
- Class 1 (kWh) according to EN62053-1 Class B (kWh) according to EN50470
- Pulse open collector output
- Modbus, RTU, Modbus Ethernet or M-bus communication port

MAIN FEATURES

- Direct or external CT measurement in a very compact housing to save space
- Suitable for measuring generated and consumed energy
- MID Annex D certification available

3-phase energy analyzers



EM330 / EM340

- Dimensions: 3 DIN modules
- Backlit touch LCD
- Measurement of voltage, current, power, power factor and frequency
- Bi-directional energy metering on 2 8-digit counters, Class B (EN50470)
- Measuring inputs: 3 x 230 (400) VAC, 5 A (EM330) 65 A (EM340)
- Power supply: auxiliary 90 to 260 VAC/DC (EM330) - self-powered (EM340)

MAIN FEATURES

- Pulse output or as an alternative: RS485 Modbus, M-Bus
- Sealable terminal covers
- CE approved and MID Annex D certification available
- cULus approved up to 480 VLL (EM330)

Our product range

3-phase energy analyzers



EM210

- Dimensions: 4 DIN modules or 72x72mm
- DIN-rail or panel mounting in a single product
- 3-phase energy meters with CT/VT, 0.333V current sensors, or Rogowski coils connection
- Measurement of voltage, current, power, power factor and frequency
- Self-powered (MID version: 230 VAC power supply)
- Pulse output
- RS485 Modbus RTU, high speed (up to 115 kbps)

MAIN FEATURES

- CE, cULus MID Annex D certification available (CT connection)
- Sealable terminal covers

Quick-fit 3-phase energy analyzers



EM271 + TCDM

- Dimensions: 4-DIN rail module or 72 x 72 mm housing
- Two 3-phase energy analyzers with sum function
- Current measurement by triple CT, split-core with RJ plug
- Equivalent to class 1 (kWh)
- Two pulse open collectors and serial RS485 outputs

MAIN FEATURES

- Save 90% of the installation time
- Voltage and serial bus daisy chain connection
- Fast and error-proof CT connection with CT ratio self-recognition

Current transformers



CTD / TADK

- CTD: currents from 40 to 4000 A
- TADK2: 1-250 A
- Removable panel fixing clips
- DIN rail and panel mounting facility (TAD...)
- Double screw terminals (CTD)
- Sealable covers
- Case: ABS, self-extinguishing level UL 94 V-0
- Accuracy class: 0.5

MAIN FEATURES

- Wound primary (TADK2)/ solid core or split-core (CTD)
- According to EN61869-2
- Removable DIN rail mounting holder
- cURus recognised by UL

Contactless power analyzers



CPA050/CPA300/CPA300-V

- 63 x 46 x 25 mm (CPA050); 99 x 89 x 30 mm (CPA300/300-V) w/o connectors, DIN rail and panel mounting
- Power analyzer (CPA050/CPA300)
- Current transducer for PV installations up to 1500 VDC (CPA300-V)
- Power supply from 9 to 30 VDC

MAIN FEATURES

- Contactless Hall effect sensing for both DC and AC(1-400 Hz) currents
- Voltage range: 800 VAC, 1000 VDC
- Current range: 50 AAC, 50 ADC (CPA050) 300 AAC, 400 ADC (CPA300/300-V)
- Modbus RS485 and analogue output (CPA300-V)

Interface protections



PI-DIN

- Dimensions: 90 x 71 x 66 mm
- Monitoring relay for 1-phase or 3-phase systems with or without neutral / Voltage and frequency protection
- 4 inputs (CEI021) or 2 inputs (VDE0126), 2 outputs
- Auxiliary power supply 230 VAC or 24 VDC

MAIN FEATURES

- Easy set-up and events display by means of front joystick
- Password protected settings, Dual Function Alarm LED
- Certified according to Italian CEI 0-21 2012-06 and V1:2012-12 and German VDE0126-1-1: 2013-08

Surge protecting devices



DSC

- Dimensions: 90 x 72 x 70 mm
- Class I and II
- Protective element: High Energy MOV
- High surge discharge rating: Iimp = 12.5 kA per pole
- Housing: compact design

MAIN FEATURES

- Specifically designed for PV installations with or without LPS (Lightning Protection System)
- Location of use: photovoltaic system - PV module side

Surge protecting devices



DSB / DSF

- Dimensions: 90 x 36 x 72 mm
- Class II
- Available for PV and AC installations
- Models for communication lines
- Optional remote monitoring
- DIN rail mounting

MAIN FEATURES

- NO backup fuse required
- Approval according to IEC61643-11 and UTE C61-740-51
- Complies with prEN50539-11

Surge protecting devices



DSB51XXS

- Dimensions: 90 x 12 x 71.5 mm DIN-rail housing
- 5 VDC nominal voltage
- 10 kA Inom, 20 kA Imax
- Rated spark overvoltage 184 V to 276 V
- C1/C2/C3 according to IEC 61643-21

MAIN FEATURES

- Designed for RS485 serial communication lines
- Three stage topology with dual GDT
- Socket with replaceable cartridge

Renewable Energy

Our product range

DIN rail DC/DC converters



DCC 24151K-D

- DIN rail mounting
- Ultra wide input: 100 ~ 1000 VDC
- 24 VDC output 15 W
- High efficiency up to 80%
- Wide temperature range -40 to +70° C
- Output over voltage and short circuit protection
- Reverse input protection

MAIN FEATURES

- Widely used in photovoltaic power generation with high voltage inverters
- It provides stable operating voltage to low voltage DC equipment

Switching power supplies



SPM

- Compact DIN housing - 1/3/4/5 DIN width
- Universal input 90-264 VAC/120-370 VDC
- Output powers from 7.5 W to 100 W
- Integrated short-circuit and overload protection with built-in input filters
- 1-phase and battery charger versions available
- CE, cULus, cURus, UL1310 Class 2 (up to 91.2 W), ISA 12.12.1 Class 1 Div2 and TÜV

MAIN FEATURES

- Operating temperature w/o derating -25°C to +60°C
- Short circuit and Overload protection
- High efficiency (up to 89%)

Digital modular indicators



UDM60 / UDM40 / USC

- Dimensions: 48 x 96 x 105 mm
- Modular Controller for pulse signals (UDM60)
- Multi-input modular instrument (UDM40, USC)
- Dual 6-DGT (UDM60), 3 colour led (UDM40)
- NPN, PNP, NAMUR, TTL, Pick-up, free of voltage contacts and AC signal inputs
- Multi-input modular instrument (UDM40, USC)
- Dual rate, speed, frequency and period measurement (0.001 Hz to 50 kHz)

MAIN FEATURES

- Digital panel meter for current, voltage, temperature, resistance, rate, frequency, speed and period measurements

Temperature sensors



TEMPSOL / IKE20001K

- Temperature Pt100 or Pt1000 (TEMPSOL)
- Temperature Pt1000 (IKE20001K)
- ±0.3°C connection type
- 2 wire connection type

MAIN FEATURES

- Specifically designed to measure the temperature of PV panels (TEMPSOL)
- For air temperature measurement in PV plants (IKE20001k)

Irradiation sensors



PVS-1

- Dimensions: 57 x 48 x 15 mm (not including clamp)
- Sensor type: crystalline silicon cell
- No need for external power supply (self-powered)
- Long lasting 3% accuracy, thanks to a special antiageing treatment
- Calibration process according to IEC 60904-2 and 60904-4
- Two available versions: 4-20 mA output / 0-80 mV output

MAIN FEATURES

- Long life rugged aluminium case
- UV resistant resin encapsulation
- Fast installation, thanks to the clamping system

Pyranometers



PVS-2A

- Dimensions: 162 x 215 x 40 mm (not including clamp)
- 2nd class thermopile pyranometer
- 4-20 mA output for reliable connections
- Calibration certificate according to ISO 9847

MAIN FEATURES

- Compact and rugged IP67 aluminium case
- Compliant with WMO (World Meteorological Organization) for environmental monitoring
- Compliant with ISO9060 and IEC17025 for photovoltaic monitoring

Anemometers / Wind vanes



DWS-D / DWS-V

- Rotor size: 145 mm
- PNP & NPN open collector output in 1 unit
- Rotor: black painted stainless steel
- Wind vane for relative wind direction (0 and 90 degree internals -DWS-DAC13) (+/- 7 degree of wind direction, L/R wind indication DWS-D-DDC13)
- Opto-electronic detection (DWSV...)
- Measuring range 2 to 30 m/s
- Current source output 10 to 28 VDC supply

MAIN FEATURES

- Opto-electronic detection
- All inputs and outputs are protected against reverse polarity and transients
- Dust sealed stainless steel ball bearing

Accessory modules



SIUFO

- 4-DIN size; DIN-rail mounting
- SIUF01: RS485 to single loop fibre optic conversion / SIUF02: RS485 to double loop fibre optic conversion
- Power supply from 12 to 18 VAC or from 10 to 24 VDC

MAIN FEATURES

- Modbus/Jbus(RTU) compliant
- Wire to optical fiber and optical fiber to wire conversion
- Compatible with Multimode Optical fiber
- Up to 160 transceivers on the same bus
- Up to 247 Modbus addresses, automatically managed
- Baudrate and RS485 parameters selectable by dip-switches



OUR SALES NETWORK IN EUROPE

AUSTRIA

Carlo Gavazzi GmbH
Ketzergrasse 374,
A-1230 Wien
Tel: +43 1 888 4112
Fax: +43 1 889 10 53
office@carlogavazzi.at

BELGIUM

Carlo Gavazzi NV/SA
Mechelsesteenweg 311,
B-1800 Vilvoorde
Tel: +32 2 257 4120
Fax: +32 2 257 41 25
sales@carlogavazzi.be

DENMARK

Carlo Gavazzi Handel A/S
Over Hadstensevej 40,
DK-8370 Hadsten
Tel: +45 89 60 6100
Fax: +45 86 98 15 30
handel@gavazzi.dk

FINLAND

Carlo Gavazzi OY AB
Ahventie, 4 B
FI-02170 Espoo
Tel: +358 9 756 2000
myynti@gavazzi.fi

FRANCE

Carlo Gavazzi Sarl
Zac de Paris Nord II, 69, rue de la Belle Etoile,
F-95956 Roissy CDG Cedex
Tel: +33 1 49 38 98 60
Fax: +33 1 48 63 27 43
french.team@carlogavazzi.fr

GERMANY

Carlo Gavazzi GmbH
Pfnorstr. 10-14
D-64293 Darmstadt
Tel: +49 6151 81000
Fax: +49 6151 81 00 40
info@gavazzi.de

GREAT BRITAIN

Carlo Gavazzi UK Ltd
4.4 Frimley Business Park,
Frimley, Camberley, Surrey GU16 7SG
Tel: +44 1 276 854 110
Fax: +44 1 276 682 140
sales@carlogavazzi.co.uk

ITALY

Carlo Gavazzi SpA
Via Milano 13,
I-20020 Lainate
Tel: +39 02 931 761
Fax: +39 02 931 763 01
info@gavazziacbu.it

NETHERLANDS

Carlo Gavazzi BV
Wijkermeerweg 23,
NL-1948 NT Beverwijk
Tel: +31 251 22 9345
Fax: +31 251 22 60 55
info@carlogavazzi.nl

NORWAY

Carlo Gavazzi AS
Melkeveien 13,
N-3919 Porsgrunn
Tel: +47 35 93 0800
Fax: +47 35 93 08 01
post@gavazzi.no

PORTUGAL

Carlo Gavazzi Lda
Rua dos Jerónimos 38-B,
P-1400-212 Lisboa
Tel: +351 21 361 7060
Fax: +351 21 362 13 73
carlogavazzi@carlogavazzi.pt

SPAIN

Carlo Gavazzi SA
Avda. Iparraguirre, 80-82,
E-48940 Leioa (Bizkaia)
Tel: +34 94 480 4037
Fax: +34 94 431 6081
gavazzi@gavazzi.es

SWEDEN

Carlo Gavazzi AB
V:a Kyrkogatan 1,
S-652 24 Karlstad
Tel: +46 54 85 1125
Fax: +46 54 85 11 77
info@carlogavazzi.se

SWITZERLAND

Carlo Gavazzi AG
Verkauf Schweiz/Vente Suisse
Sumpfstrasse 3,
CH-6312 Steinhausen
Tel: +41 41 747 4535
Fax: +41 41 740 45 40
info@carlogavazzi.ch

OUR SALES NETWORK IN THE AMERICAS

USA

Carlo Gavazzi Inc.
750 Hastings Lane,
Buffalo Grove, IL 60089, USA
Tel: +1 847 465 6100
Fax: +1 847 465 7373
sales@carlogavazzi.com

CANADA

Carlo Gavazzi Inc.
2660 Meadowvale Boulevard,
Mississauga, ON L5N 6M6, Canada
Tel: +1 905 542 0979
Fax: +1 905 542 22 48
gavazzi@carlogavazzi.com

MEXICO

Carlo Gavazzi Mexico S.A. de C.V.
Circuito Puericultores 22, Ciudad Satelite
Naucalpan de Juarez, Edo Mex. CP 53100
Mexico
T +52 55 5373 7042
F +52 55 5373 7042
mexicosales@carlogavazzi.com

BRAZIL

Carlo Gavazzi Automação Ltda.Av.
Francisco Matarazzo, 1752
Conj 2108 - Barra Funda - São Paulo/SP
Tel: +55 11 3052 0832
Fax: +55 11 3057 1753
info@carlogavazzi.com.br

OUR SALES NETWORK IN ASIA AND PACIFIC

SINGAPORE

Carlo Gavazzi Automation Singapore Pte. Ltd.
61 Tai Seng Avenue #05-06
Print Media Hub @ Paya Lebar iPark
Singapore 534167
Tel: +65 67 466 990
Fax: +65 67 461 980
info@carlogavazzi.com.sg

MALAYSIA

Carlo Gavazzi Automation (M) SDN. BHD.
D12-06-G, Block D12,
Pusat Perdagangan Dana 1,
Jalan PJU 1A/46, 47301 Petaling Jaya,
Selangor, Malaysia.
Tel: +60 3 7842 7299
Fax: +60 3 7842 7399
sales@gavazzi-asia.com

CHINA

Carlo Gavazzi Automation
(China) Co. Ltd.
Unit 2308, 23/F.,
News Building, Block 1, 1002
Middle Shennan Zhong Road,
Shenzhen, China
Tel: +86 755 83699500
Fax: +86 755 83699300
sales@carlogavazzi.cn

HONG KONG

Carlo Gavazzi Automation
Hong Kong Ltd.
Unit 3 12/F Crown Industrial Bldg.,
106 How Ming St., Kwun Tong,
Kowloon, Hong Kong
Tel: +852 23041228
Fax: +852 23443689

OUR COMPETENCE CENTRES AND PRODUCTION SITES

DENMARK

Carlo Gavazzi Industri A/S
Hadsten

MALTA

Carlo Gavazzi Ltd
Zejtun

ITALY

Carlo Gavazzi Controls SpA
Belluno

LITHUANIA

Uab Carlo Gavazzi Industri Kaunas
Kaunas

CHINA

Carlo Gavazzi Automation (Kunshan) Co., Ltd.
Kunshan

HEADQUARTERS

Carlo Gavazzi Automation SpA
Via Milano, 13
I-20020 - Lainate (MI) - ITALY
Tel: +39 02 931 761
info@gavazziautomation.com



CARLO GAVAZZI
Automation Components

Energy to Components!

www.gavazziautomation.com

