

New Products

No. 121

Direct from IDEC Corporation

May 15, 2004



- *Four sensing methods*
- *IP67 (NEMA 6) waterproof design*
- *Compact size*
- *Cable and M8 connector types available*
- *Choose NPN output, PNP output, light ON, or dark ON*
- *Long sensing ranges, high-speed response*
- *Part numbers and list prices on page 4*

Small & Affordable SA1E Photoelectric Sensors

Originally announced in February of 2003, IDEC is pleased to present our latest line of photoelectric sensors, the SA1E series. The SA1E series was developed to provide a space saving, flexible, and economical choice for the sensor market. These new and improved high performance miniature sensors come in several different styles which makes them ideal for the OEM market, machine builders and small, size-restricted applications.

New Features

The SA1E series are extremely compact at 31.5mm tall, 19.5mm wide, and 10.8mm deep. There are 32 different models available with four sensing methods; through beam, polarized retro-reflective, diffuse-reflective, and small-beam reflective styles of detection. They have long sensing ranges and a high-speed response time of 1 ms making it one of the fastest and most

adaptable sensors on the market. All are CE marked and IP67 (NEMA 6) rated making the SA1E sensor water-resistant for industrial cleaning and maintenance. With advanced interference protection circuitry (except for the through-beam type) these sensors can be mounted very close together without affecting their performance. Each model also has several options. You can choose between fixed cable or M8 removable connector types, NPN or PNP outputs, and light ON or dark ON sensing modes.

Accessories include brackets for horizontal or vertical mounting, slits for through-beam type sensors, reflectors for polarized retro-reflective types, and M8 quick connector cables for the connector type.

Product Advantages

One big advantage the SA1E series has

con't on page 3

Table of Contents

New Features.	Cover
SA1E Sensor Examples	2
Market Information	3
Part Numbers & List Prices	4



Through-Beam Type

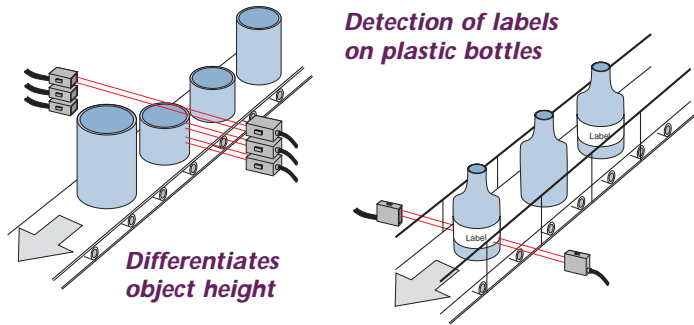

- Most reliable for detecting opaque objects
- Longer sensing range, up to 10m
- Higher-precision results when used for leading edge or positioning applications
- Can detect small objects by using optimal slit
- Use for detection of labels on transparent containers

Diffuse-Reflective

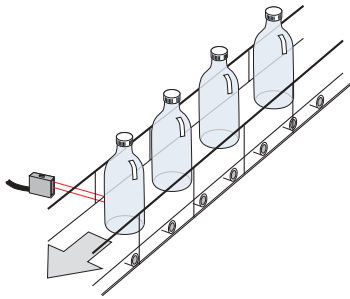

- Space Saving
- Reflective transparent objects detectable

Polarized Retro-Reflective

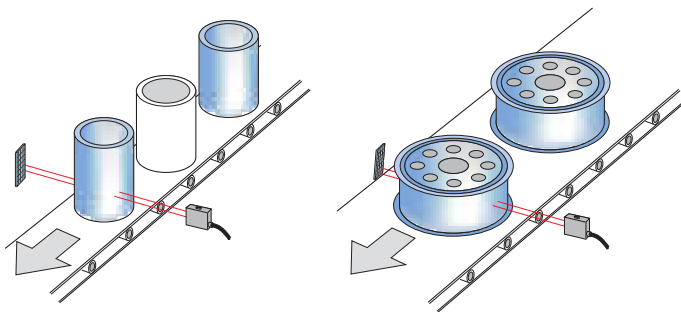

- Good for sensing large objects
- Suited for mirror-like objects
- Uses polarization for shiny objects
- Can be installed in a limited space
- Longer detecting distance than the reflective sensor type

Small-Beam Reflective

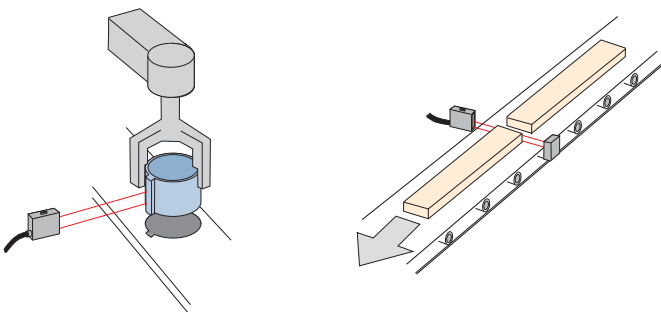

- Minute objects detectable
- Target marking detectable
- Detection possible through narrow slit between machines

IDEC vs. Competators	IDEC	Keyence	Omron	Banner
Models	SA1E	PZ Series	E3Z	VS3
Through Beam	10m	7m	15m	1.2m
Polarized Retroreflective	2.5m	2.5m	1.0m	2.5m
Diffuse Reflective	700mm	600mm	100mm	—
Small Beam	150mm	100mm	—	—
Response Time	1 ms	1 ms	1ms	1ms
Cable/Connector Type	yes	yes	yes	yes
Ratings	IP 67	IP 67	IP 67	IP 67
List Price	\$35-\$50	\$109-\$145	\$75-\$113	\$36-\$100

con't from page 1

over the competition is price. You will find the SA1E to be very competitively priced and flexible enough to be used in a variety of industries and operations. The table above will show you comparisons with other top suppliers and the direct cross-reference models to the SA1E.

The SA1E series has longer sensing ranges than the competitors'. The through beam sensors have a sensing range up to 10 meters (the use of the slits will provide an even smaller beam size, great for detecting tiny objects in restricted areas). The polarized retro-reflective type has a sensing range up to 2.5 meters, the diffuse reflective sensor has a range up to 700 millimeters, and the small beam reflective type has a range up to 150 millimeters.

Since they are dust-tight and water-resistance (conforming to IP 67) they can be used in either extremely wet or dry environments as well as being used for ordinary applications. Another advantage of using the SA1E sensors is the option of using connector cables that allow for easy maintenance, installation, or replacement of either an amplifier or cable.

Market Information

The North America market for photoelectric sensors is projected to be about \$400 million this year. This is more than 50% higher than the market level in the early 1990s. In the overall market of photoelectric sensors Allen-Bradley is the largest supplier and has about 40% of the U.S. market. Banner has 25% and

others (IDEC, Keyence, Omron, Baumer, Sick, and Sunx) have 35%. If we look at the miniature photo-electric sensor market compared to the SA1E, Banner has the biggest segment of the market and the other manufacturers follow. (See the table above for a comparison of the SA1E to other suppliers' models.)

The highest overall growth markets will be material handling, food processing/packaging, and machine tools/automatic machinery.

IDEC's core customer base of small and medium sized machine builders who use products from the competitors are our first target. We believe with our present price structure we should be able to increase market share dramatically.

Applications

The SA1E can be used in a wide range of industries and applications. Many manufacturing and process applications can use the SA1E to detect or differentiate products. It can be used for quality control, sorting, object detection, and controlling production volume, to name just a few applications. Target industries include:

con't on page 4

2004 FORECAST

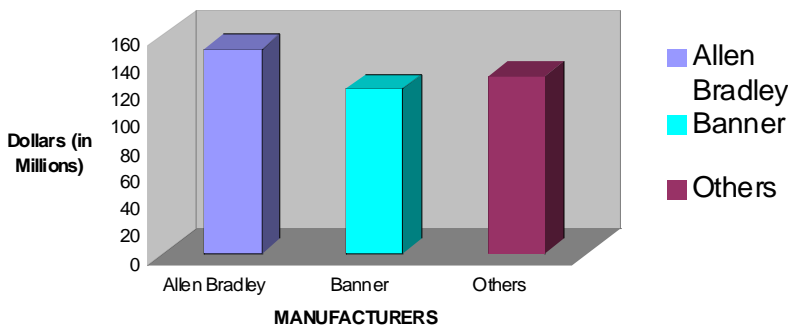

con't from page 3

- *Automotive Industry*
- *Material Handling*
- *Food Processing and Packaging*
- *Rubber/Plastics Manufacturing Machine Tools/Automatic Machinery*
- *Metal/Steel Industries*
- *Construction Material*
- *ICs & Electronics Components Assembly*
- *Military/Aerospace Applications*

Many uses can be found in material handling and automation environments, such as mail sorting facilities or pick and place robotic systems. One example is when the sensor is used on an assembly line to detect the presence of an object at a certain manufacturing completion point. Knowing when an object is present a robot arm can then automatically move it to the next manufacturing process.

Food processing and packaging industries also have many applications. For example, the SA1E can be used to detect labels on food containers, counting cereal packages or differentiating the height of canned goods. Another use could be in water dispensers to detect the presence of a container before dispensing water.

The Machine Tool and Automation Machinery industries use the SA1E to count the number of parts that have been manufactured, or to differentiate the shape of products which are ready for packaging. The sensors are also used to maintain quality control throughout the manufacturing process. An example of this would be when sensors are used to detect the presence (or absence) of screw placements.

If you would like additional information please visit our direct website at: www.idec.com/usa/sa1e, contact IDEC Technical Support at support@idec.com, or call 1-800-262-IDEDEC (press 2).

IDEC Corporation
1-800-262-IDEDEC (4332)
1175 Elko Drive • Sunnyvale, CA 94089
Fax: 408-745-5258 • www.idec.com

©2004 IDEC Corporation. All Rights Reserved.

SA1E Photoelectric Sensors - Part Numbers & List Prices

SA1E-DN1	Diffuse reflective, NPN, light ON, cable	\$35.00
SA1E-DN1C	Diffuse reflective, NPN, light ON, connector	\$45.00
SA1E-DN2	Diffuse reflective, NPN, dark ON, cable	\$35.00
SA1E-DN2C	Diffuse reflective, NPN, dark ON, connector	\$45.00
SA1E-DP1	Diffuse reflective, PNP, light ON, cable	\$35.00
SA1E-DP1C	Diffuse reflective, PNP, light ON, connector	\$45.00
SA1E-DP2	Diffuse reflective, PNP, dark ON, cable	\$35.00
SA1E-DP2C	Diffuse reflective, PNP, dark ON, connector	\$45.00
SA1E-NN1	Small beam, NPN, light ON, cable	\$40.00
SA1E-NN1C	Small beam, NPN, light ON, connector	\$50.00
SA1E-NN2	Small beam, NPN, dark ON, cable	\$40.00
SA1E-NN2C	Small beam, NPN, dark ON, connector	\$50.00
SA1E-NP1	Small beam, PNP, light ON, cable	\$40.00
SA1E-NP1C	Small beam, PNP, light ON, connector	\$50.00
SA1E-NP2	Small beam, PNP, dark ON, cable	\$40.00
SA1E-NP2C	Small beam, PNP, dark ON, connector	\$50.00
SA1E-PN1	Retro-reflective, NPN, light ON, cable	\$35.00
SA1E-PN1C	Retro-reflective, NPN, light ON, connector	\$45.00
SA1E-PN2	Retro-reflective, NPN, dark ON, cable	\$35.00
SA1E-PN2C	Retro-reflective, NPN, dark ON, connector	\$45.00
SA1E-PP1	Retro-reflective, PNP, light ON, cable	\$35.00
SA1E-PP1C	Retro-reflective, PNP, light ON, connector	\$45.00
SA1E-PP2	Retro-reflective, PNP, dark ON, cable	\$35.00
SA1E-PP2C	Retro-reflective, PNP, dark ON, connector	\$45.00
SA1E-TN1	Through-beam, NPN, light ON, cable	\$40.00
SA1E-TN1C	Through-beam, NPN, light ON, connector	\$50.00
SA1E-TN2	Through-beam, NPN, dark ON, cable	\$40.00
SA1E-TN2C	Through-beam, NPN, dark ON, connector	\$50.00
SA1E-TP1	Through-beam, PNP, light ON, cable	\$40.00
SA1E-TP1C	Through-beam, PNP, light ON, connector	\$50.00
SA1E-TP2	Through-beam, PNP, dark ON, cable	\$40.00
SA1E-TP2C	Through-beam, PNP, dark ON, connector	\$50.00

Accessories - Part Numbers & List Prices

SA9Z-S06	0.5 mm slit for through beam	\$5.00
SA9Z-S07	1.0 mm slit for through beam	\$5.00
SA9Z-S08	2.0 mm slit for through beam	\$5.00
IAC-R5	Standard reflector	\$8.86
IAC-R6	Small reflector	\$6.00
IAC-RS1	Tape relector	\$6.00
IAC-L2	Mounting bracket for IAC-R5	\$4.12
IAC-L3	Mounting bracket for IAC-R6	\$6.00
SA9Z-K01	Sensor vertical mounting bracket	\$4.00
SA9Z-K02	Sensor horizontal mounting bracket	\$4.00
SA9Z-CM8K-4S2	Connector cable, straight, 2m	\$20.00
SA9Z-CM8K-4L2	Connector cable, right angle, 2m	\$26.00
SA9Z-CM8K-4S5	Connector cable, straight, 5m	\$20.00
SA9Z-CM8K-4L5	Connector cable, right angle, 5m	\$26.00