

PCB LAYOUT/TOP VIEW

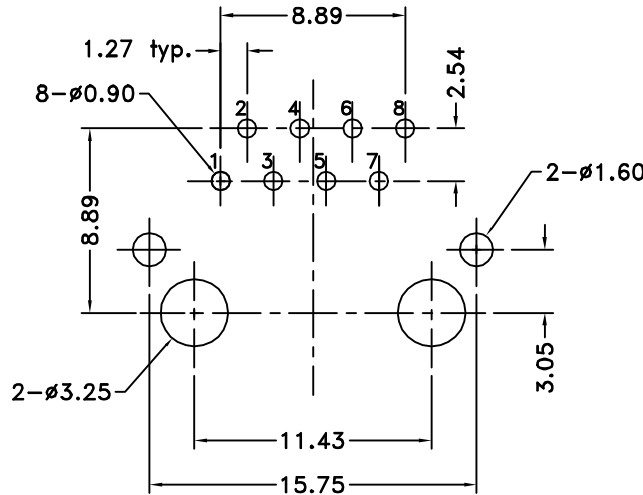
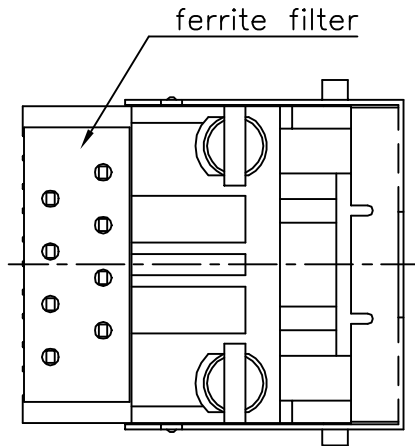

Part Number	Contact Plating Finish
GDLF-S3A-88-50	50u" Gold

**Materials and Finish**

Housing Material-  
PBT Thermoplastic  
UL 94V-0 Rated  
Color: Black

Shield Material-  
Nickel Alloy- Tin or Nickel Plated

Contact Material-  
Phosphor Bronze

Contact Plating-  
50 Option: 0.0001" Nickel Plating,  
Selective Plating 0.00050"  
Gold on Contact Area to  
Comply with FCC Requirements  
Under No. 47 C.F.R. Part 68,  
Subpart F

**Electrical Characteristics**

Insulation Resistance-  
500 Megohms Min.

Dielectric Withstanding Voltage-  
1000V rms, 60Hz

Contact Resistance-  
20 milliohms Max.

Current Rating-  
1.5 Amps

Ferrite Specifications	
Test Frequency	Impedance
1 Mhz	1 ohm
10 Mhz	7 ohms
30 Mhz	13 ohms
50 Mhz	16 ohms
100 Mhz	21 ohms

CSA NRTL/C Certified File No. LR78160

REVISION	DATE	DESCRIPTION	DRAWN BY	DESIGNED BY	UNITS
A04	1/10/01	ref. ECD #01-005	C. Leiva		mm
A05	1/15/01	reverse & correct boardlock orientation on bottom view, change shield plating to tin or nickel	CHECKED BY	APPROVED BY	DATE
A1	10/3/01	Ref ECD 01-150			10/22/00

GDLF-S3A-88-50

Shielded Mod. Jack, 8 position/8 contacts

Angled Grounding Flaps, Extended Shield, Ferrite Filtered

