



Description

The Model 88 is a programmable LCD Totalizer, with eight 7-segment digits that are 0.35" [9mm] in height. The standard display is a backlit LCD, providing red characters on a dark background. An optional reflective LCD with dark characters on a light background is available. Unit programming is accomplished using four front-panel switches, or programming can be done using the optional serial data interface and dedicated PC-based software (Redi-Ware), which is available from Redington free of charge. Upon power up, the Totalizer performs internal diagnostics and flashes all segments of the display "ON" and "OFF" several times. The Totalizer then configures itself per previous programming, loads the internal Counters and Timers with their values prior to power down, and begins normal operation.

The Model 88 Programmable Totalizer is capable of receiving input pulses, processing those input pulses in a number of different, selectable ways, and then displaying the results. The Totalizer is capable of operating in a single-up count mode, as well as add-subtract, directional counting, add-add, and three levels of quadrature. In addition, the unit can support independent counting of two separate inputs. Counts can be pre-scaled by scale factors ranging from -9.9999 to 99.9999 or from -9.9999 x 10^-3 to 99.9999 x 10^-3. Maximum count speed is up to 40KHz for single count modes and 20KHz for the dual count mode. Maximum input speed can be limited by enabling an analog filter on each input, thereby protecting count integrity from unwanted noise. The input format can also be selected. In addition, a serial data interface option is available to report counts from remote locations or to program the Totalizer. Each Model 88 base unit is normally powered from a DC voltage of +10V to +32 V. However, an AC power supply module # 200557-002S can be attached to the rear of the unit that converts +90VAC to +250VAC, to +12VDC, which can be used to power the Model 88 and an external sensor.

Features

- Dual up counting
- Directional counting
- 1,2,4x quadrature
- Add/add counting
- Add/subtract counting
- Prescaling of counts
- NEMA 4X/IP56 sealed panel
- UL, cUL Recognized, CE Compliant UL file # E19514

Options

- Serial Comm. (RS232, RS422, RS485)
- Display color
- AC Power Module 200557-002S
+90 VAC to +285 VAC, 50/60 Hz (unit is normally powered from +10 VDC to +32 VDC)

Specifications

Display:	LCD, 8 digits, 0.35" [9mm] negative image transmissive red or positive image reflective display. In the negative count mode the display will be 7 digits with a "-" sign. (Reflective display recommended in sunlight)	Sensor Power:	+12VDC @ 100mA, minimum (200557-002S Module)
Annunciators:	A, B, LOCK, 0.039" [1mm]	Front Panel Lockout:	Two front panel lockouts are available. In the programming mode, the operator is prohibited from entering new parameters. In the operating mode, the lockout disallows manual reset of any displayed inputs.
Programming:	Programming is accomplished through the front panel switches or by serial data interface and dedicated PC software, supplied by Redington Counters, Inc.	Count Inputs (Input A & Input B):	Software selectable: switch contact or voltage input Software Selectable: filter: no filter or 160 Hz 1 st order L.P. Voltage Mode V _{IH} : 2.4VDC, min. Voltage Mode V _{IL} : 0.8VDC, max. or open circuit Switch Mode V _{IH} : 2.4 VDC, min. or open circuit Switch Mode V _{IL} : 0.8VDC, max. Maximum Input voltage: 32.0VDC Minimum Input voltage: -0.8VDC
Available Functions:	Totalizer Directional Counting Three different quadrature resolutions Add-Add Add-Subtract Dual Count	Counter Operational Format:	Input A is used for all count functions Input B is used for all dual Input counter functions (i.e. ADD/ADD, ADD-SUB, DIRECTIONAL COUNT, QUADRATURE, and DUAL COUNT).
Programmable Decimal Point:	Counter A: 4 decimal point locations may be selected. Counter B: 4 decimal point locations may be selected.	Input Scaling:	A & B Counters (-9.9999 to 99.9999, or -9.9999 x 10 ⁻³ to 99.9999 x 10 ⁻³)
Power Requirements:	Base unit: +10VDC TO +32VDC @ 50mA max. AC Power Supply: Model 200557-002S; +90VAC to +250 VAC 50/60 Hz @ 6 VA max.	Quadrature Counting:	Software selectable X1, 2, 4
Memory:	Nonvolatile EEPROM retains all program parameters and values when power is removed. EEPROM provides 20 year data retention.		



Max. Count Rate: 40 KHz for single counter mode.
20 KHz for dual count modes.

Reset Functions: Manual and remote.

RS232/RS485/RS422 Serial Communications: (Optional)
Baud Rate: Selectable 2400, 4800, 9600, or 19.2K
Data Length/Parity/Stop Bits: 8n1
RS485 Address: Programmable from 0 to 99.
Transceiver Loading: RS232/RS485/RS422- up to 16 loads

Certifications & Compliances:
UL, cUL- Recognized Component, file # E 195514
CE-Compliant to EN 61326: 1998 for industrial equipment

Environmental Conditions:
Operating Temperature: -4°F to +140°F [-20°C to +60°C]
Storage Temperature: -40°F to +185°F [-40°C to +85°C]

Operating & Storage Humidity: to 95% (non-condensing) from -4°F to +140°F [-20°C to +60°C]
Altitude: Up to 6561Ft. (2000 Meters)

Electrical Connection: Wire clamping screw terminals

Construction: High impact black plastic case with "Clip" type mount. Front panel meets NEMA 4X/IP65 requirements for indoors use, when properly installed. Oversized front panel flange insures proper sealing of panel cutouts. Gaskets for front panel are provided.

Panel Thickness: 0.05" to 0.20" [1.3 to 5.1mm]

Weight: Less than 3 oz. (85g)

Ordering Information

MODEL NUMBER	DESCRIPTION	DISPLAY RED TRANSMISSIVE	DISPLAY REFLECTIVE	ANALOG INPUT	ANALOG OUTPUT	RS-485 RS-232 RS 422
8803-0000	Base unit, Red Trans., 10-30VDC, Prescale	X				
8813-0000	Base unit, Reflective, 10-30VDC, Prescale		X			
8803-0100	Red Trans., 10-30VDC, Prescale, Serial Communications	X				X
8813-0100	Reflective, 10-30VDC, Prescale, Serial Communications		X			X

ACCESSORIES

200557-002S AC Voltage module, +90VAC to +250VAC also outputs +12VDC for base unit & sensor

Note: Reflective display is recommended for applications that will be exposed to direct sunlight

* All parts are normally in factory stock.

Dimensions

Model 88 Totalizer

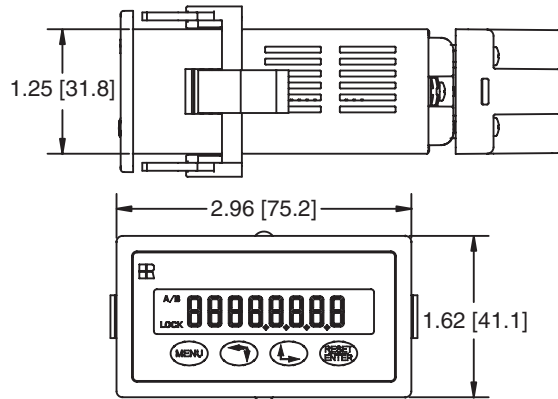
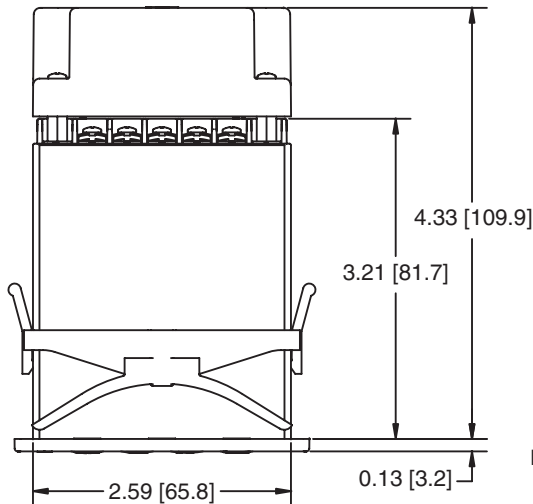

Panel Cutout 2.63" to 2.605" x 1.28" to 1.26" [66.8 to 66.2 x 32.5 to 32.0]
Max. thickness of panel 0.5" [12.7]

Applications

Flow meter

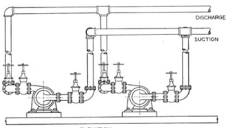

Panel builders

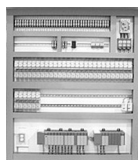

Piece count

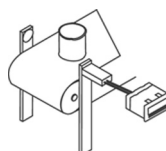

Secondary equipment

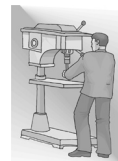

Test equipment

