

»» Features

- 10A general purpose Power Relay.
- Contact rating up to 12A 250VAC (DPNO).
- Epoxy sealed type and flux free.
- Quick connect terminal or PCB terminal available.
- Special version of larger contact gap 1.9mm. (IEC 255/VDE 0436) (DPNO Only)
- Optional to be equipped with lamp, diode, flashed contact, and flanged cover.
- Complies with RoHS-Directive 2011/65/EU.



»» Type List

Terminal style	Contact form	Designation (provided with)	Enclosure style			
			Straight cover	Flanged cover	Sealed type	Sealed type washable
Quick terminal	DPDT	-----	SCL-DPDT	SCL-DPDT-C1	SCL-DPDT-V	SCL-DPDT-S
	DPNO	-----	SCL-DPNO	SCL-DPNO-C1	SCL-DPNO-V	SCL-DPNO-S
	DPDT	Diode	SCL-D-DPDT	SCL-D-DPDT-C1	SCL-D-DPDT-V	SCL-D-DPDT-S
	DPNO	Diode	SCL-D-DPNO	SCL-D-DPNO-C1	SCL-D-DPNO-V	SCL-D-DPNO-S
	DPDT	Lamp	SCL-L-DPDT	SCL-L-DPDT-C1	SCL-L-DPDT-V	SCL-L-DPDT-S
	DPNO	Lamp	SCL-L-DPNO	SCL-L-DPNO-C1	SCL-L-DPNO-V	SCL-L-DPNO-S
PCB terminal	DPDT	-----	SCL-1-DPDT	-----	SCL-1-DPDT-V	SCL-1-DPDT-S
	DPNO	-----	SCL-1-DPNO	-----	SCL-1-DPNO-V	SCL-1-DPNO-S
	DPDT	Diode	SCL-1-D-DPDT	-----	SCL-1-D-DPDT-V	SCL-1-D-DPDT-S
	DPNO	Diode	SCL-1-D-DPNO	-----	SCL-1-D-DPNO-V	SCL-1-D-DPNO-S
	DPDT	Lamp	SCL-1-L-DPDT	-----	SCL-1-L-DPDT-V	SCL-1-L-DPDT-S
	DPNO	Lamp	SCL-1-L-DPNO	-----	SCL-1-L-DPNO-V	SCL-1-L-DPNO-S
	DPDT	Manual	SCL-1-M-DPDT	-----	-----	-----
	DPNO	Manual	SCL-1-M-DPNO	-----	-----	-----

»» Ordering Information

SCL - - - DPDT - -
 1 2 3 4 5 6 7

- | | |
|--|---|
| 1. SCL -- Basic series designation | DPNO -- Double pole normally open |
| 2. Blank -- Quick terminal | 5. Blank -- Standard type |
| 1 -- PCB terminal | F -- Class F |
| 3. Blank -- Without special features | 6. Blank -- Straight cover |
| L -- Provided with pilot light | C1 -- Flanged cover |
| D -- Diode across coil | V -- Sealed type |
| M -- Provided with manual operator | S -- Sealed type washable |
| H -- 2 mm contact gap (For DPNO and DC coil type only) | 7. <input type="checkbox"/> -- Coil voltage (please refer to the coil rating data for the availability) |
| 4. DPDT -- Double pole double throw | |

»» Contact Rating

◆ Standard Type

Resistive load	10A 240VAC , 10A 28VDC
----------------	------------------------

◆ SCL-H Type

Resistive load	15A 240VAC
Max. switching voltage	250VAC
Max. switching current	15A
Max. switching capacity	3600VA

»» Coil Rating (DC)

◆ Standard Type

Rated voltage (V)	Rated current $\pm 10\%$ at 23°C (mA)	Coil resistance $\pm 10\%$ at 23°C (Ω)	Max. continuous voltage at 70°C	Pick up voltage(Max.) at 23°C	Drop out voltage(Min.) at 23°C	Power consumption at rated voltage
6	150	40	110 % of rated voltage	75 % of rated voltage	10 % of rated voltage	approx. 0.9W
9	100	90				
12	75	160				
15	60	250				
24	37	650				
48	19	2600				
60	15	4000				
110	10	11000				
120	11	11000				

◆ SCL-H Type

Rated voltage (V)	Rated current $\pm 10\%$ at 23°C (mA)	Coil resistance $\pm 10\%$ at 23°C (Ω)	Max. continuous voltage at 70°C	Pick up voltage(Max.) at 23°C	Drop out voltage(Min.) at 23°C	Power consumption at rated voltage
3	400	7.5	115 % of rated voltage	80 % of rated voltage	10 % of rated voltage	approx. 1.2W
6	200	30				
9	133.3	67.5				
12	100	120				
24	50	480				
48	25	1920				
60	20	3000				
100	12	8330				
110	10.9	10080				
120	10	12000				

»» Coil Rating (AC)

Rated voltage (V)	Coil resistance $\pm 10\%$ at 23°C (Ω)	Max. continuous voltage at 70°C	Pick up voltage(Max) at 23°C	Drop out voltage(Min) at 23°C	Power consumption at rated voltage
12	40	110 % of rated voltage	85 % of rated voltage	30 % of rated voltage	approx. 1.2VA
24	160				
100	3400				
110	3400				
115	3400				
120	3400				
220	13600				
230	13600				
240	13600				

»» Specification

Contact material	AgSnO alloy	
Contact resistance ⁽¹⁾	30 m Ω Max.; (-H) 50 m Ω Max. (at 1A/6VDC by 4-wire resistance measurement)	
Operate time ⁽¹⁾	25 ms Max.	
Release time ⁽¹⁾	25 ms Max.	
Insulation resistance ⁽¹⁾	100 M Ω Min. (DC 500V)	
Dielectric strength ⁽¹⁾	Between open contact	: AC 1000V , 50/60Hz 1 min.
	Between contact and coil	: AC 1500V , 50/60Hz 1 min.
	Between contact circuits	: AC 1500V , 50/60Hz 1 min.
Vibration resistance	Operating extremes	10~55Hz , amplitude 1.0 mm
	Damage limits	10~55Hz , amplitude 1.0 mm
Shock resistance	Operating extremes	20G ; (-H) 10G
	Damage limits	100G
Life expectancy	Mechanical	10,000,000 operations ; (-H) 3,000,000 ops. (frequency 18,000 operations/hr)
	Electrical	100,000 operations (frequency 1,800 operations/hr) [(-H)1,200 ops/hr]
Operating ambient temperature	-25~+70°C (no freezing)	
Weight	Approx. 35 g	

Note : (1) Initial value. Operate and release time excluding contact bounce.

»» Safety Approval

◆ Standard Type

Certified	UL / CUL	CSA	TUV
File No.	E88991	1474290	R50055516

◆ SCL-H Type

Certified	UL / CUL	TUV
File No.	E88991	R50055516

»» Safety Approval Rating

◆ Standard Type

UL / CUL	CSA	TUV
10A 277VAC/28VDC	10A 277VAC/28VDC	10A 250VAC
15A 125VAC	15A 125VAC	10A 30VDC
1/3HP 7.5FLA 125VAC	1/3HP 7.5FLA 125VAC	
1/2HP 5.0FLA 250VAC	1/2HP 5.0FLA 250VAC	
1/3HP 3.0FLA 277VAC	1/3HP 3.0FLA 277VAC	
15A 240VAC (DPNO ONLY)	15A 240VAC (DPNO ONLY)	

◆ SCL-H Type

UL / CUL	TUV
16A 277VAC 1/2HP 250VAC	15A 250VAC

»» Outline Dimensions

◆ SCL (C1)

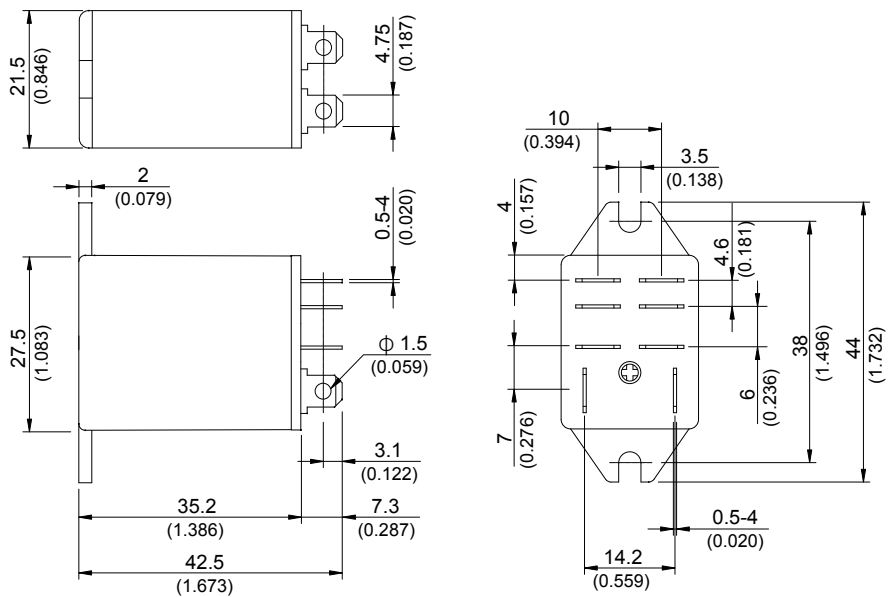

◆ SCL

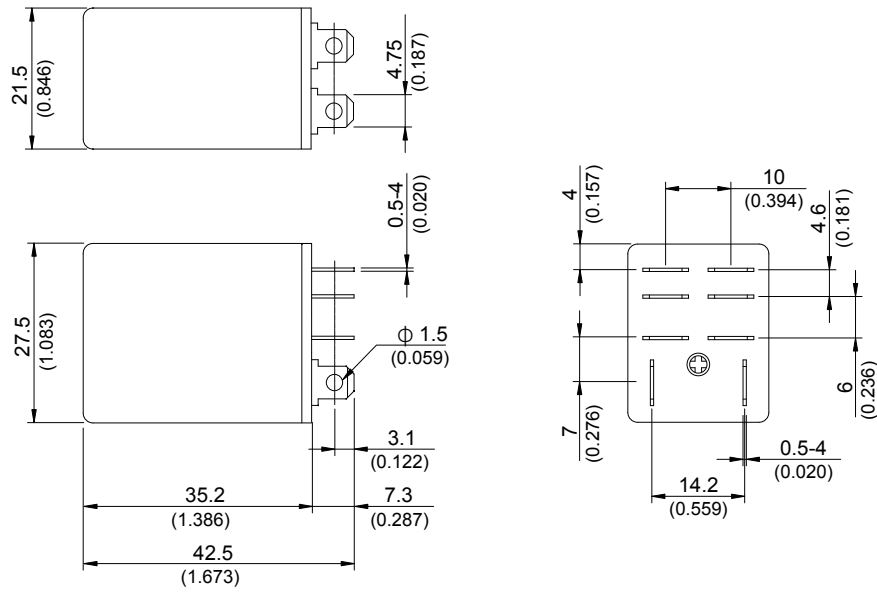

◆ SCL-1

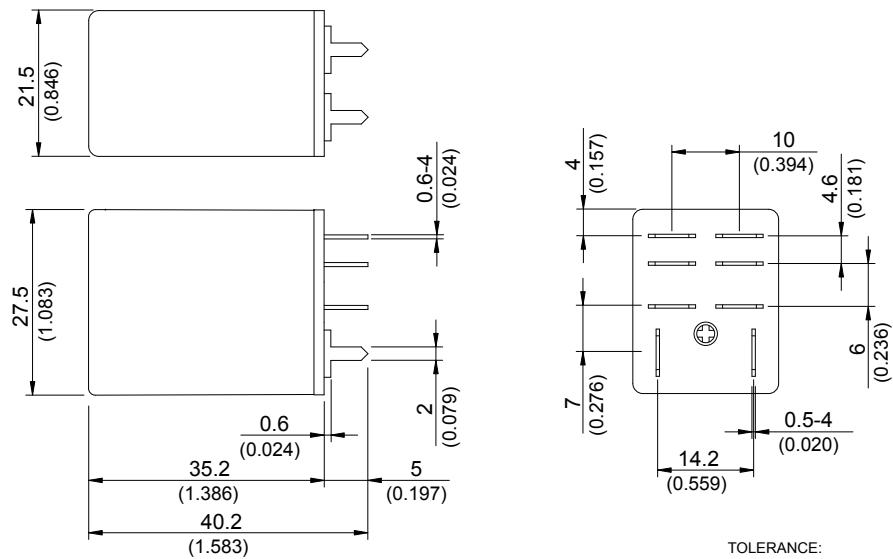

TOLERANCE:
 LESS THAN: 1(0.039) $\pm 0.1(0.004)$
 5(0.197) $\pm 0.3(0.012)$
 20(0.787) $\pm 0.5(0.020)$
 MORE THAN: 20(0.787) $\pm 1(0.039)$

»» Wiring Diagram
 BOTTOM VIEW

DPDT

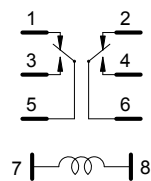

DPNO

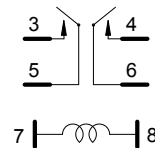

PC Board Layout BOTTOM VIEW

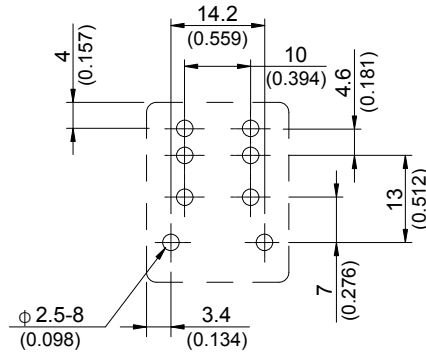

Designation(Provided with) BOTTOM VIEW

Lamp

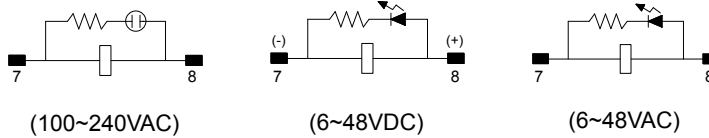

Diode

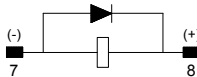

Engineering Data

DC coil

