

»» Features



- 20A/25A general purpose Power Relays.
- SPDT, DPDT, TPDT contact configurations.
- DC & AC coils are both available.
- Optional for flange covers, tapped core w/anti-rotation tab, indicator lamp, push-to-test button, PCB terminals
- Complies with RoHS-Directive 2011/65/EU.

»» Type List

◆ Standard Type

Terminal style	Contact form	Enclosure style				
		Open type	Dust cover	Ears on cover	Antirotation-tab	Ears on top
Quick terminal	1A (SPNO)	735-1A	735-1A-C	735-1A-C1	735-1A-C2	735-1A-C3
	1B (SPNC)	735-1B	735-1B-C	735-1B-C1	735-1B-C2	735-1B-C3
	1C (SPDT)	735-1C	735-1C-C	735-1C-C1	735-1C-C2	735-1C-C3
	2A (DPNO)	735-2A	735-2A-C	735-2A-C1	735-2A-C2	735-2A-C3
	2B (DPNC)	735-2B	735-2B-C	735-2B-C1	735-2B-C2	735-2B-C3
	2C (DPDT)	735-2C	735-2C-C	735-2C-C1	735-2C-C2	735-2C-C3
	3A (TPNO)	735-3A	735-3A-C	735-3A-C1	735-3A-C2	735-3A-C3
	3B (TPNC)	735-3B	735-3B-C	735-3B-C1	735-3B-C2	735-3B-C3
	3C (TPDT)	735-3C	735-3C-C	735-3C-C1	735-3C-C2	735-3C-C3
PCB terminal	1A (SPNO)	-----	735-1A-C-T	-----	-----	-----
	1B (SPNC)	-----	735-1B-C-T	-----	-----	-----
	1C (SPDT)	-----	735-1C-C-T	-----	-----	-----
	2A (DPNO)	-----	735-2A-C-T	-----	-----	-----
	2B (DPNC)	-----	735-2B-C-T	-----	-----	-----
	2C (DPDT)	-----	735-2C-C-T	-----	-----	-----
	3A (TPNO)	-----	735-3A-C-T	-----	-----	-----
	3B (TPNC)	-----	735-3B-C-T	-----	-----	-----
	3C (TPDT)	-----	735-3C-C-T	-----	-----	-----

◆ High Power Type

Terminal style	Contact form	Insulation system	Enclosure style	
			Dust cover	Ears on cover
Quick terminal	1A (SPNO)	F	735H-1A-F-C	735H-1A-F-C1
	1B (SPNC)		735H-1B-F-C	735H-1B-F-C1
	1C (SPDT)		735H-1C-F-C	735H-1C-F-C1
	2A (DPNO)		735H-2A-F-C	735H-2A-F-C1
	2B (DPNC)		735H-2B-F-C	735H-2B-F-C1
	2C (DPDT)		735H-2C-F-C	735H-2C-F-C1

Ordering Information

735 - 2C - - -

1 2 3 4 5 6 7

- | | | | |
|----------|--------------------------------|-----------------------------|---|
| 1. 735 | -- Basic series designation | 5. Blank | -- Open type |
| 2. Blank | -- Standard type | C | -- With cover |
| H | -- High power type | C1 | -- With mounting ears on cover |
| 3. 1A | -- Single pole normally open | C2 | -- With accessible mounting hole with anti-rotation tab |
| 1B | -- Single pole normally closed | C3 | -- Mounting ears on top of cover |
| 1C | -- Single pole double throw | 6. Blank | -- No special feature |
| 2A | -- Double pole normally open | M | -- With manual operator |
| 2B | -- Double pole normally closed | T | -- Printed circuit board terminals |
| 2C | -- Double pole double throw | L | -- Pilot lamp |
| 3A | -- Three pole normally open | 7. <input type="checkbox"/> | -- Coil voltage (please refer to the coil rating data for the availability) |
| 3B | -- Three pole normally closed | | |
| 3C | -- Three pole double throw | | |
| 4. Blank | -- Standard type | | |
| F | -- Class F | | |

Contact Rating

TYPE	735		735H
	1A, 1B, 1C, 2A, 2B, 2C	3A, 3B, 3C	
Resistive load	20A 240VAC 15A 28VDC	20A 120VAC 15A 240VAC/28VDC	30A 240VAC 15A 28VDC

Coil Rating (DC)

◆ Standard Type

	Rated voltage (V)	Rated current ±10 % at 23°C (mA)	Coil resistance ±10 % at 23°C (Ω)	Max. continuous voltage at 50°C	Pick up voltage(Max.) at 23°C	Drop out voltage(Min.) at 23°C	Power consumption at rated voltage
SP DP	6	188	32	130 % of rated voltage	80 % of rated voltage	10 % of rated voltage	approx. 1.2W
	12	100	120				
	24	51	472				
	48	27	1800				
	110	11	10000				
	125	12.5	10000				
TP	6	250	24	130 % of rated voltage	80 % of rated voltage	10 % of rated voltage	approx. 1.5W
	12	125	96				
	24	63	384				
	48	31	1536				
	110	11.5	9600				
	125	13	9600				



◆ High Power Type

Rated voltage (V)	Rated current $\pm 10\%$ at 23°C (mA)	Coil resistance $\pm 10\%$ at 23°C (Ω)	Max. continuous voltage at 55°C	Pick up voltage(Max.) at 23°C	Drop out voltage(Min.) at 23°C	Power consumption at rated voltage
6	188	32	100 % of rated voltage	80 % of rated voltage	10 % of rated voltage	approx. 1.2W
12	100	120				
24	51	472				
48	27	1800				
110	11	10000				
125	12.5	10000				

»» Coil Rating (AC)

◆ Standard Type

Rated voltage (V)	Coil resistance $\pm 10\%$ at 23°C (Ω)	Max. continuous voltage at 50°C	Pick up voltage(Max.) at 23°C	Drop out voltage(Min.) at 23°C	Power consumption at rated voltage	
SP DP	6	4.2	110 % of rated voltage	85 % of rated voltage	30 % of rated voltage	approx. 3.0VA
	12	18				
	24	72				
	110	1580				
	120	1700				
	220	5850				
TP	6	3.9	110 % of rated voltage	85 % of rated voltage	30 % of rated voltage	approx. 3.4VA
	12	14.5				
	24	64				
	110	1450				
	120	1540				
	220	5850				
	240	6750				

◆ High Power Type

Rated voltage (V)	Coil resistance $\pm 10\%$ at 23°C (Ω)	Max. continuous voltage at 55°C	Pick up voltage(Max.) at 23°C	Drop out voltage(Min.) at 23°C	Power consumption at rated voltage
6	4.2	100 % of rated voltage	85 % of rated voltage	30 % of rated voltage	approx. 3.4VA
12	18				
24	72				
110	1580				
120	1700				
220	5850				
240	7200				

»» Specification

Contact material	AgSnO alloy	
Contact resistance ⁽¹⁾	50 mΩ Max. (for 735) ; 100 mΩ Max. (for 735H) (at 1A/6VDC by 4-wire resistance measurement)	
Operate time ⁽¹⁾	25 ms Max.	
Release time ⁽¹⁾	20 ms Max.	
Insulation resistance ⁽¹⁾	1000 MΩ Min. (DC 500V)	
Dielectric strength ⁽¹⁾	Between open contact	: AC 1000V, 50/60Hz 1 min. (for 735) : AC 1500V, 50/60Hz 1 min. (for 735H)
	Between contact and coil	: AC 1600V, 50/60Hz 1 min. (for 735) : AC 3000V, 50/60Hz 1 min. (for 735H)
	Between contact circuits	: AC 1600V, 50/60Hz 1 min. (for 735) : AC 3000V, 50/60Hz 1 min. (for 735H)
Vibration resistance	Operating extremes	10~55Hz, amplitude 2.0 mm
	Damage limits	10~55Hz, amplitude 2.0 mm
Shock resistance	Operating extremes	10G
	Damage limits	100G
Life expectancy	Mechanical	10,000,000 operations (frequency 18,000 ops./hr)
	Electrical	100,000 operations (frequency 1,200 ops./hr) (for 735)
		NO: 30,000 operations NC: 10,000 operations (frequency 360 ops./hr) (for 735H)
Operating ambient temperature	-30~+50°C (no freezing) (for 735) -30~+55°C (no freezing) (for 735H)	
Weight	Approx. 80 g	

Note : (1) Initial value. Operate and release time excluding contact bounce.

»» Safety Approval

Certified	735		735H
	UL / CUL	CSA	UL / CUL
File No.	E88991	1664125	E88991

»» Safety Approval Rating(UL / CUL · CSA)

UL / CUL			CSA		
735 1A, 1B, 1C	735 2A, 2B, 2C	735 3A, 3B, 3C	735 1A, 1B, 1C	735 2A, 2B, 2C	735 3A, 3B, 3C
25A 28VDC	20A 28VDC	15A 28VDC	30A 277VAC	25A 277VAC	20A 277VAC
25A 277VAC	25A 277VAC	20A 277VAC	10A 600VAC	10A 600VAC	15A 28VDC
10A 600VAC	10A 600VAC	3/4HP 120VAC	25A 28VDC	20A 28VDC	3/4HP 120VAC
1.5HP 240VAC	1.5HP 240VAC	1HP 240VAC	1.5HP 240VAC	1.5HP 240VAC	1HP 240VAC
1HP 120VAC	1HP 120VAC		1HP 120VAC	1HP 120VAC	

UL / CUL	
735H 1A, 1B, 1C	735H 2A, 2B, 2C
30A 277VAC	30A 277VAC
25A 28VDC	20A 28VDC
10A 600VAC	10A 600VAC
1.5HP 240VAC	1.5HP 240VAC
1HP 120VAC	1HP 120VAC

»» Outline Dimensions

◆ 735 C

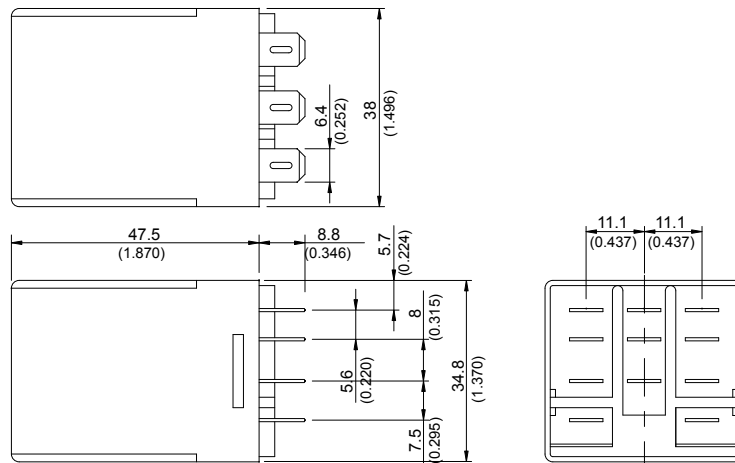

◆ 735 C1

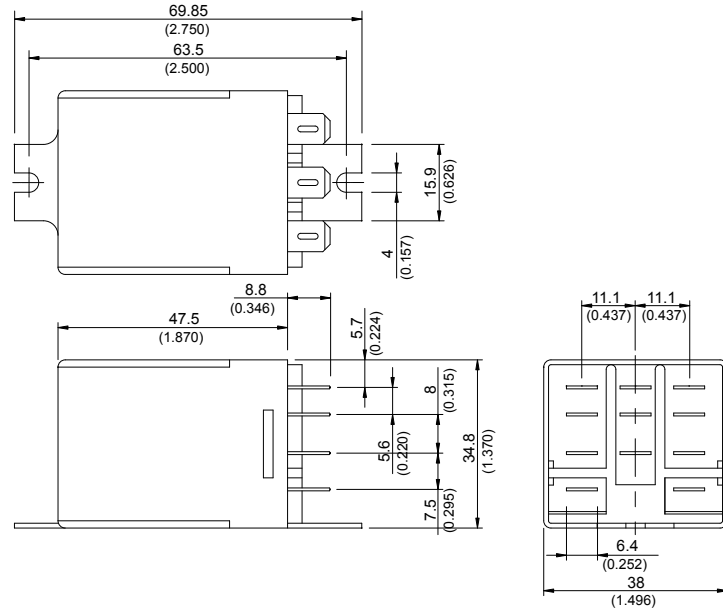

◆ 735 C2

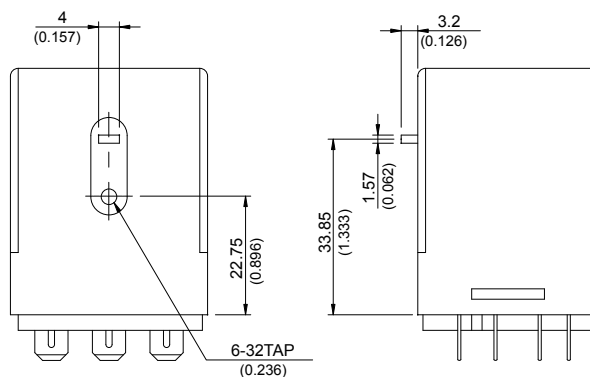

735

◆ 735 C3

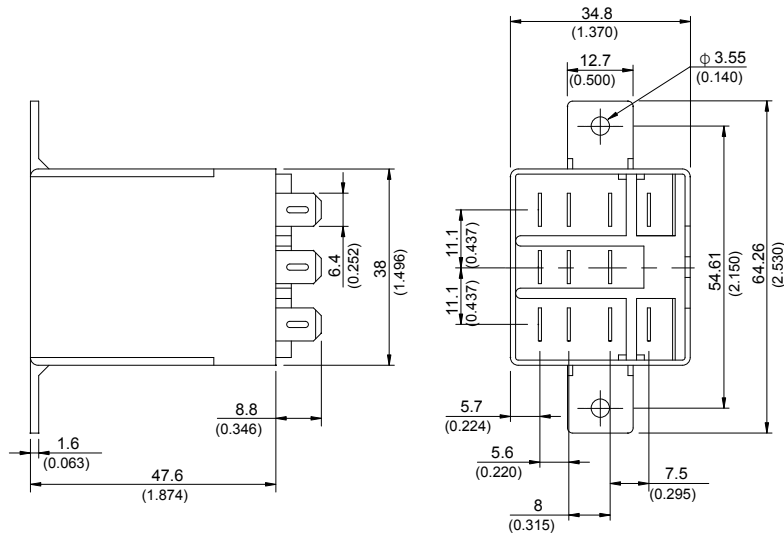

◆ 735 M

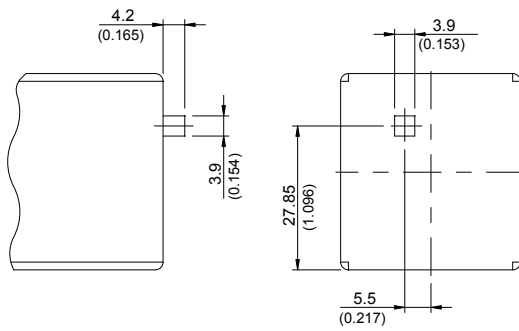

◆ 735 T

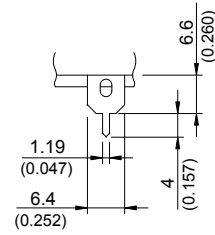

TOLERANCE:
 LESS THAN: 1(0.039) ±0.1(0.004)
 5(0.197) ±0.3(0.012)
 20(0.787) ±0.5(0.020)
 MORE THAN: 20(0.787) ±1(0.039)

»» Wiring Diagram
 BOTTOM VIEW

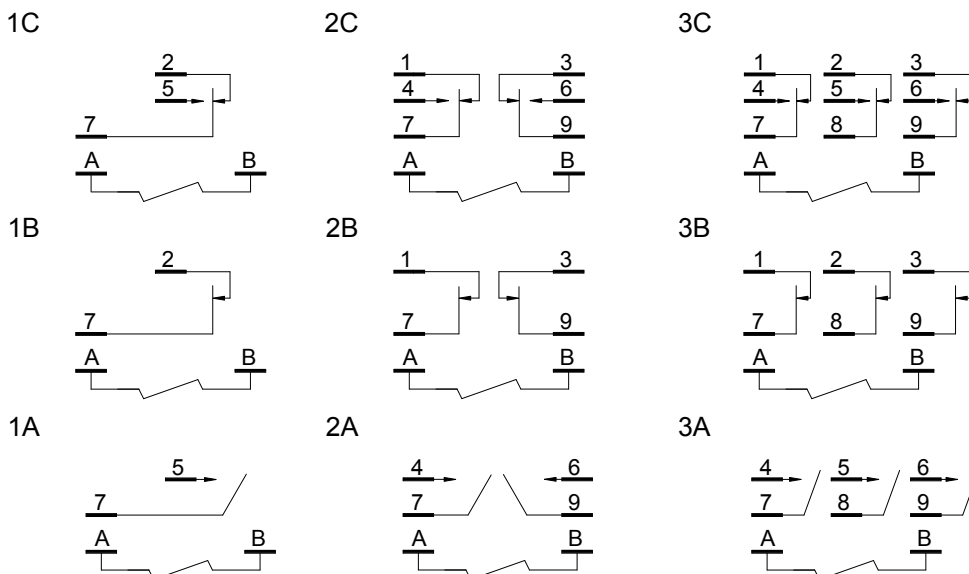

PC Board Layout BOTTOM VIEW

1P

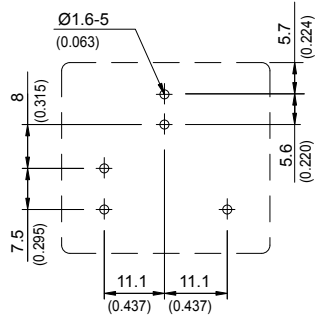

2P

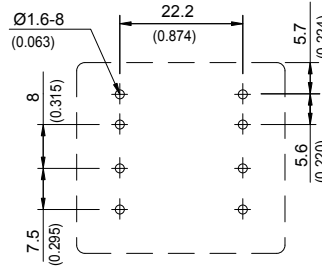

3P

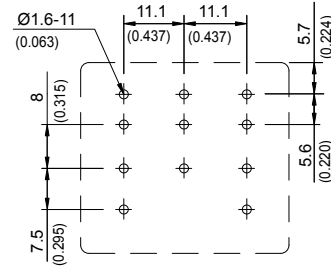

Engineering Data

